

Five minute guide

Microgrids (μ G)

ARUP

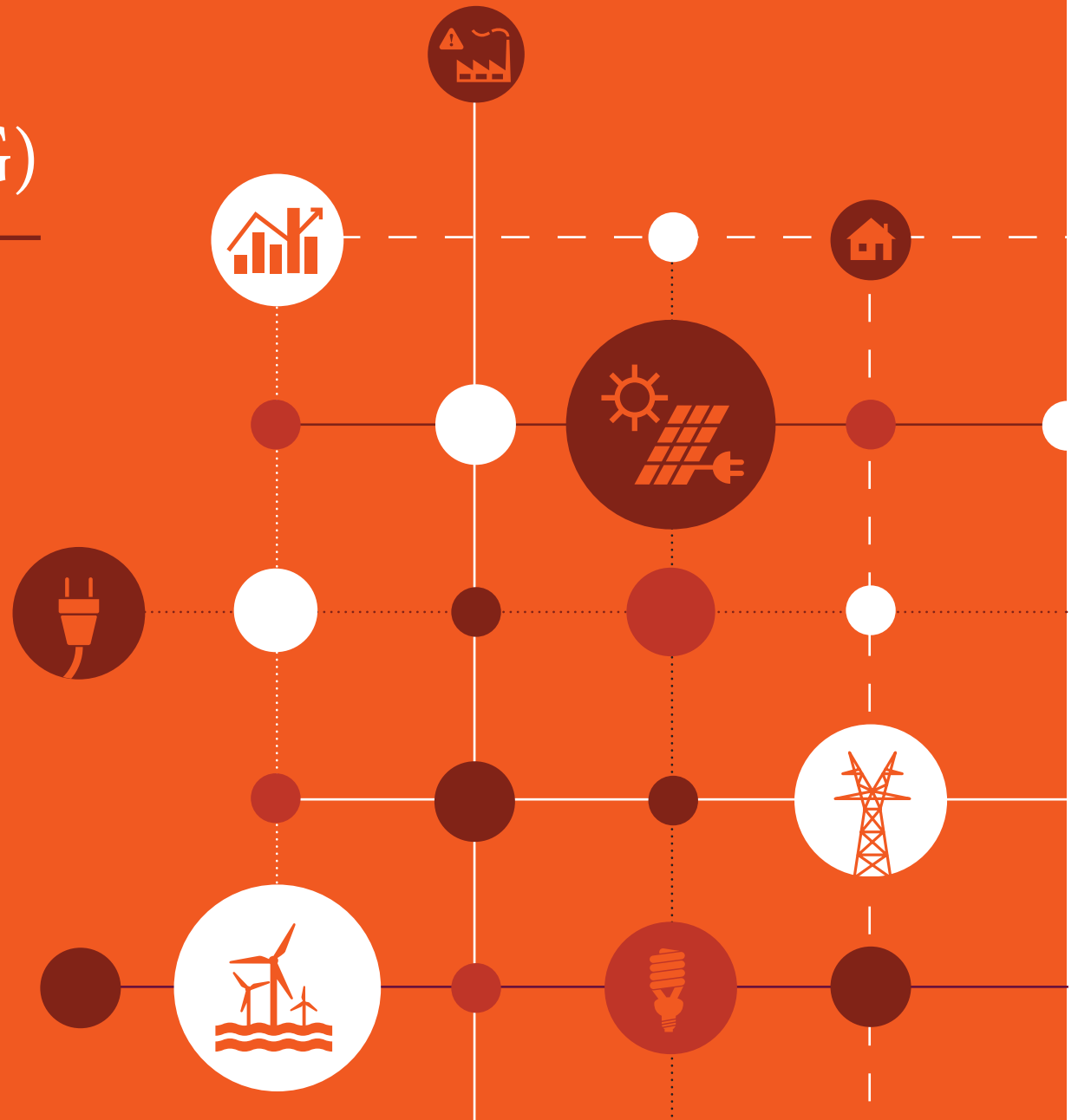

What is a Microgrid?

A microgrid is a local energy system which incorporates three key components; Generation, Storage and Demand all within a bounded and controlled network. It may or may not be connected to the grid.

A microgrid (μG) is a distributed level energy system which includes all the necessary components to operate in isolation of the grid. It is a microcosm of the broader energy network, but at a distributed level.

When operating independently of the grid in 'island' mode, a microgrid is a self-sustaining independent energy system. It can also be connected to the grid through a Point of Common Coupling (PCC), allowing it to import or export electricity as prevailing commercial or technical conditions dictate.

Microgrid generation may be from a range of variable distributed energy resources (DER's), including renewables and fossil fuelled generators. Storage may include battery arrays, electric vehicles, liquid air among others. Demand is modulated through the microgrid control systems incorporating demand response (DR) so that it can be matched to available supply in the most safe, effective and controlled way.

Microgrids are predominantly electrically based, but they can also incorporate a thermal energy component.

They operate as AC, DC, high frequency AC or a combination of all three.

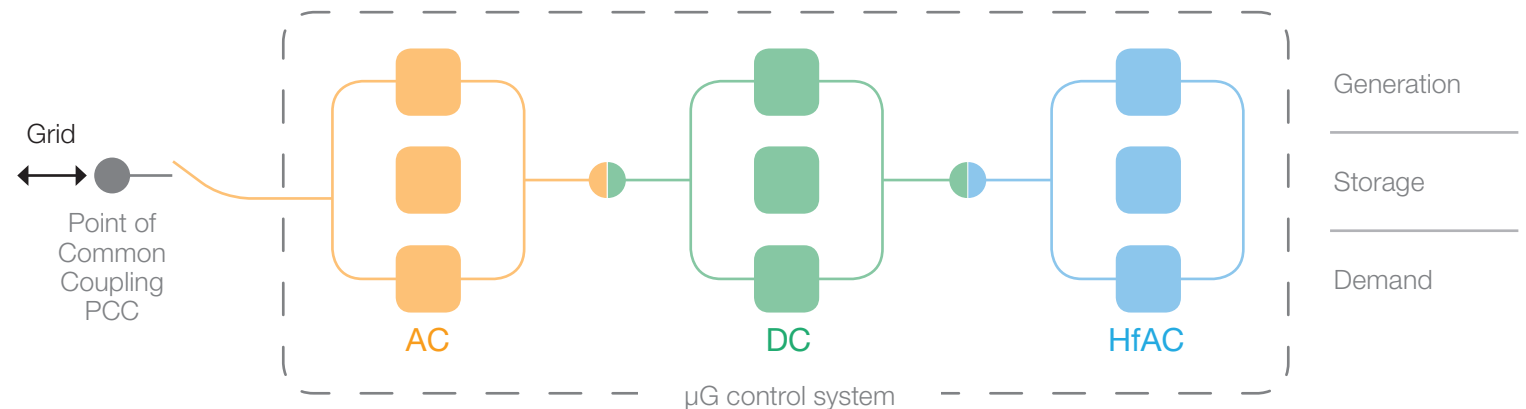

Secure, Sustainable and Affordable

A microgrid is a way to simultaneously address energy security, affordability and sustainability through dispersed, locally controlled, independent energy systems tailored precisely to end-user requirements.

Different end-users have a range of requirements from their energy supply systems. While financial institutions and high technology industries such as microchip manufacturers or data centres require absolute supply reliability, others may be more focussed on the sustainability and carbon footprint of their supply. In other circumstances, affordability may be the primary driver or simply the opportunity to have any power at all, particularly in areas where grid development is limited or supplies rely on expensive imported fossil fuels.

Secure and Reliable

By virtue of being a self-contained system, a microgrid is resilient to energy supply disruptions. The timeframe of this resilience varies from a grid independent system which can operate as long as fuel or renewable energy is available to a system which operates for short periods to protect against the undesirable effects of grid disruption.

The microgrid can focus on critical demands only, leaving sheddable loads off-line until full system availability of adequate grid supply is resumed. As well as gaining the resilience benefits of being self-contained, a microgrid can also revert to a grid supplied arrangement where beneficial.

Sustainable and Low Carbon

Increasing penetration of renewable energy into the mix brings many benefits in terms of sustainable low carbon sources while also introducing intermittency and supply/demand challenges. A microgrid is well suited to matching up intermittent renewables with a range of demand requirements. The system can maintain critical loads from renewable supply sources, while adjusting others and shedding non-critical demands until supply challenges have passed. The combination of feeding DC loads from DC sources such as photovoltaics reduces conversion losses, as does the local use of energy and reduced distribution network losses.

Affordable and Profitable

A microgrid allows the user to select the most cost effective system balance by selecting the optimal combination of indigenous supply and use, relying on grid or expensive standby supply only when cost effective. Where there is an imbalance, excess supply can be stored or dispatched to the grid. Where there is an energy shortfall or supply costs are high, then energy may be drawn from storage, and non-critical loads can be temporarily curtailed until the supply profile recovers. Minimal losses from conversion of distribution mean that energy is used cost-effectively.

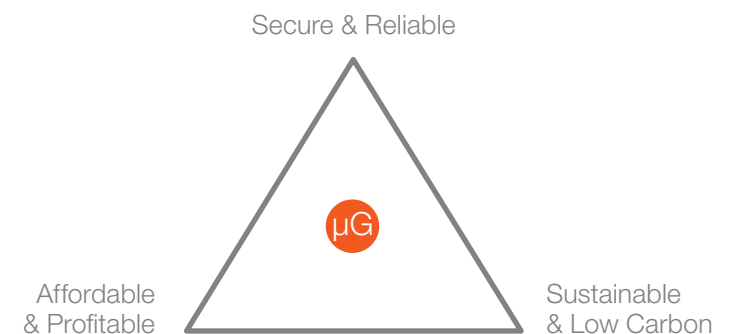

Balancing Supply and Demand

Microgrids have the ability to maintain a balance between available supply and desirable load demand through careful marriage of supply and demand combined with intelligent control of any imbalance.

Microgrids can be configured in a number of ways based on the required reliability, sustainability and affordability emphasis together with consideration of the local grid characteristics and availability. The ability of a microgrid to maintain a supply/demand balance is a key attribute.

Microgrid energy supply comprises a number of categories ranging from readily controlled to intermittent and not controllable. This range includes dispatchable generation such as diesel generators or fuel cells at one end, through predictable intermittent supply such as PV or micro-hydro and on to less predictable intermittent supply from wind generation at the other end of the scale.

Microgrid energy load has a range of controllability characteristics ranging from critical loads such as data systems or life support machinery at one end of the scale, to adjustable loads such as heating/cooling, lighting or grid dispatch at the other. The extent to which the loads can be modulated as well as the time period over which they can be changed are key characteristics. Some loads may also be temporarily curtailed where necessary.

Microgrid energy storage provides a critical supply fall-back as well as a means to ‘time-shift’ own generation to match load demands.

Each type of supply, demand and storage can be categorised on the basis of its controllability and dependability in the microgrid context:

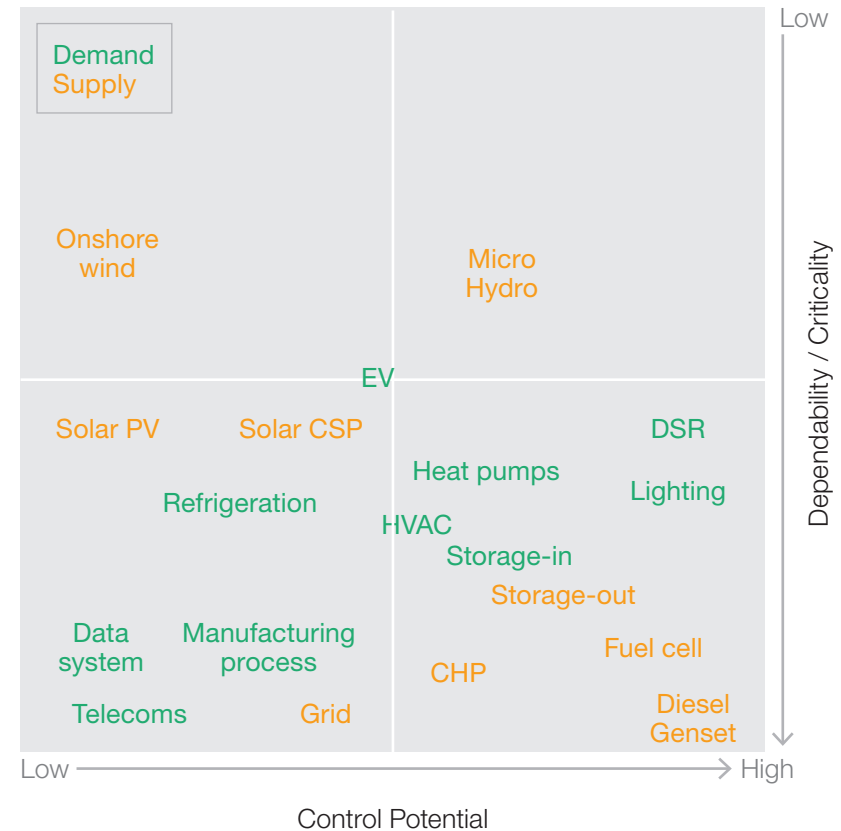

Anatomy of a Hybrid AC/DC Microgrid

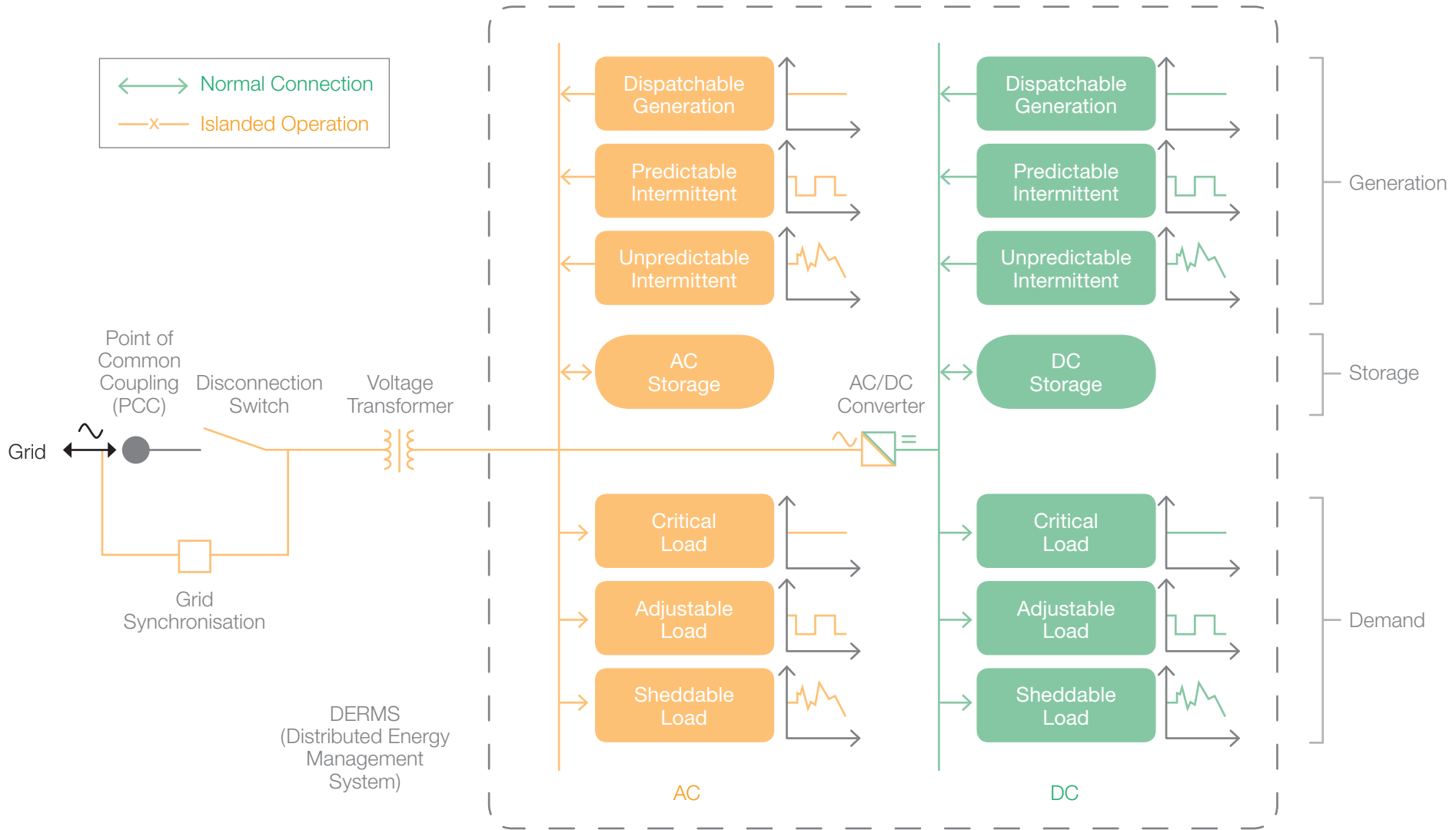

Benefits and Evolving Solutions

Benefits

Monetised

Conversion loss savings

Lower carbon cost

Reduced peak power costs

Reduced capacity charges

Increased CHP balance

Network capex avoidance

Lower network redundancy

Energy price arbitrage

Optimised own supply use

Negawatt market

Operational reserve market

Reduced fossil fuel use

Auxiliary market services

Choose lowest cost energy

Power factor services

Non-monetised

Consistent secure power

Protection of critical loads

Secure non-essential supply

Controlled power quality

Reduced blackout risk

Increased supply reliability

Reduced CO₂ intensity

Continued productivity

CSR and education benefits

Consumer engagement

Employee engagement

Supply independence

Reduced outage impact

Optimised existing system

Remote site availability

Absorption chiller level load

Visibility of energy use

Evolving Solutions

External Environment

Immature regulations

Early adopter risks

Limited standards

Emerging supply chain

Resistant utility engagement

Immature Negawatt market

Grid Interface

Additional connection cost

Synchronisation required

Conversion costs

Emerging interface standards

Smoothed demand profile

Deferred asset investment

Reduced redundant systems

Capital Asset

Can overlay existing asset

Medium term investment

Matched to client asset and need

Operation

Plug & Play compatibility

Additional skill set required

Market participation costs

ICT energy costs

Power Quality

Harmonics management

Voltage & frequency control

Power flow analysis

Protection system

Microgrid (μG) Applications

μG is a versatile approach which has a range of applications extending through off-grid communities, high-tech industries, mission critical operations and low carbon commerce.

Remote & Off-Grid

- Represents the greatest number of microgrids currently operating globally, but it has the smallest average capacity.
- Expected to continue to be a market segment driven by solar photovoltaics (PV) deployment in remote areas. Small wind is projected to play a growing role, as well.

Commercial & Industrial

- Applies either to commercial centres, and or critical manufacturing zones
- Tend to be multi-owner microgrids
- Principally driven by security and affordability
- Expected to see substantial growth in the coming years

Community & Utility

- Includes predominantly residential customers.
- Principally driven by affordability and security
- Unlikely to achieve widespread commercial acceptance until standards are in place and regulatory barriers removed

Mission Critical

- The smallest market segment currently, but starting to pick up
- Principal driver is security, by integrating Renewable Distributed Energy Generation as a way to secure power supply without being dependent on any supplied fuel or the grid.

Institutional & Campus

- Advantage of common ownership
 - Offers the best near-term development opportunity.
 - Market segment prone to development of sophisticated state-of-the-art microgrids
 - Represents 40% of the US's pipeline of micrgrids, adding 940 MW of new capacity valued at \$2.76 billion by 2015.
-

(μG) Applications – Remote or Off-grid

Sub-Saharan Village
 Out-back Community
 Low Carbon Island
 Rural Education Complex

Typically, these remote communities can be characterised as having modest energy demands which are currently poorly serviced by unreliable single point grid connections or by inefficient and expensive fossil fuel generation equipment. Renewable generation is available, but generally in the form of PV, charged batteries or reading lights. Wind power may be available as may micro hydro, however these forms of generation are seasonally as well as daily intermittent.

A microgrid can bring opportunities to develop a coherent and functional local distribution network in isolation of a future anticipated grid connection. Once a reliable grid connection reaches the community, it may be able to reduce the energy cost, but in the meantime the community can function and develop effectively, particularly in terms of education, health and light industry.

The ability of a microgrid to function effectively despite loss of grid power is advantageous to communities which rely on long single point grid connections. They may choose to rely on a mix of supply even when grid connected, but they are also able to function effectively when ‘islanded’ due to grid disruption.

A reliable, affordable microgrid-based system reduces time spent on activities such as water provision or cooking, while simultaneously providing the lighting necessary for effective education.

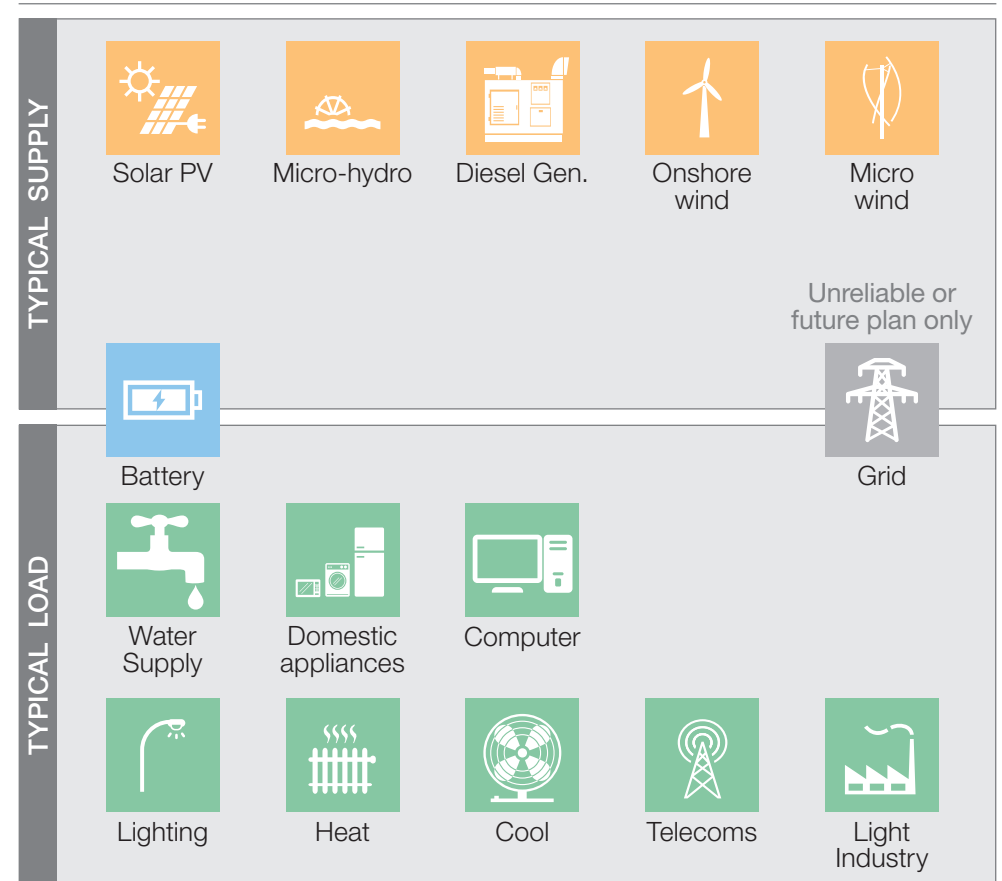
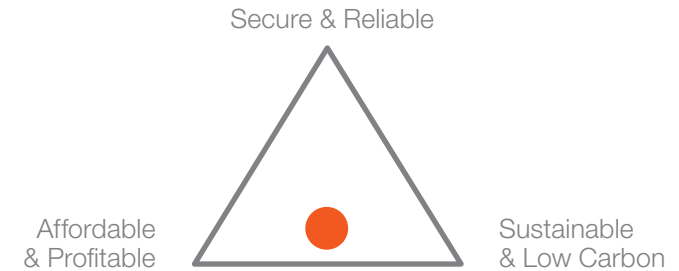

(μG) Applications – Low Carbon Leaders

Beacon Education Campus
 Blue Chip IT Campus
 Low Carbon Office
 Retail Centre

Low carbon leaders are keen to demonstrate their corporate social responsibility while also positioning themselves as pioneers in their particular field through early development and adoption of key technologies. In terms of their own real estate, this is reflected in maximum deployment of renewable energy and demand side response (DSR).

While keen to push the boundaries, these early adopters do not wish to impact their day-to-day operations and productivity simply to make a statement. They require the same or higher level of reliability from their sustainable energy supply as they would expect from a conventional grid based supply. They also wish to have the surety of a grid connection, but aim to draw an average ‘net zero’ supply in aggregate.

The deployment of a microgrid in this application enables maximum sustainable energy contribution while providing predictable outcomes for the end-user, which is a key sensitivity for high performing organisations and their real estate partners.

The ability to synchronise and dispatch energy to the distribution network or to rapidly reduce demand when ‘Negawatt’ prices make it commercially attractive are important features of this type of microgrid.

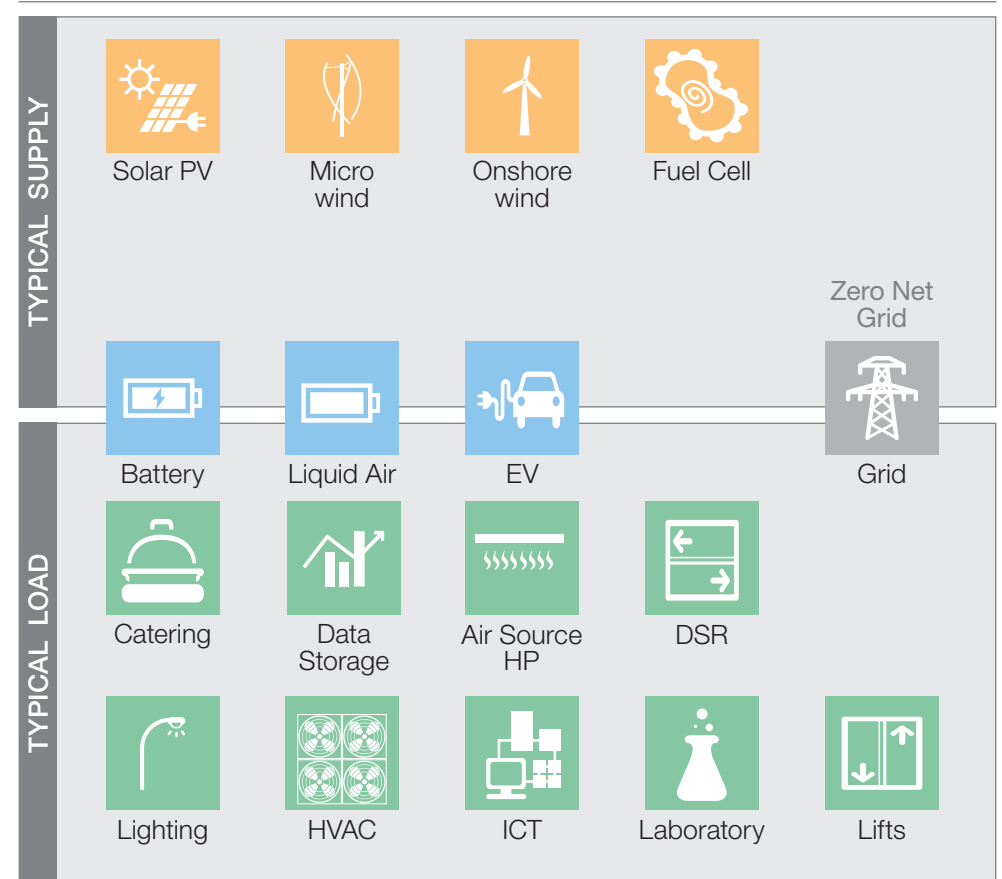
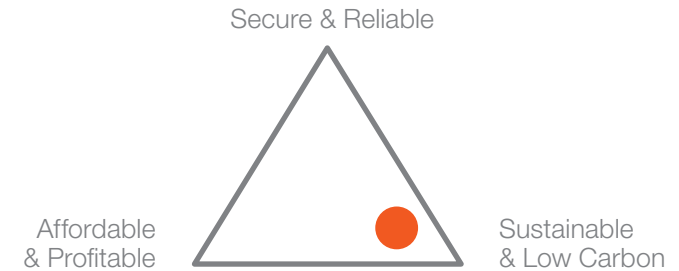

(μG) Applications – Critical Supply

Secure Stock Exchange
 Microchip or Pharmaceutical Manufacturer
 Low Carbon Data Centre
 Emergency Services & Hospitals

For certain activities and clients, the cost of losing supply can be significant in societal or financial terms. It is therefore essential that critical loads are provided with energy on demand while less important loads are reduced or temporarily shed. Emergency service reliability, production downtime, restart prevention, guaranteed trading ability and data centre availability are all critical in their specific ways.

Although it might generally be sensible for such a client to rely on a range of on and off-site supplies from grid or local renewable energy, the challenge arises when these supplies are unable to meet the demands of the overall load or more importantly the critical load itself, particularly if supply loss is due to a rapid interruption of offsite power. These rapid interruptions of power due to extreme weather, malevolent activity or extensive technical difficulties may lead to protracted loss of service, which has a financial cost.

In these circumstances, microgrid deployment can allow the critical loads to be incorporated into a much wider on-site energy network able to rapidly shed non-essential load, reallocate available indigenous supply and dispatch stored energy while back-up generation and ultimately grid restoration are completed.

The microgrid based combination of targeted load management with resilient renewables, storage and back-up generation provides a secure environment for critical load support over and above that provided solely by UPS and emergency diesel generators.

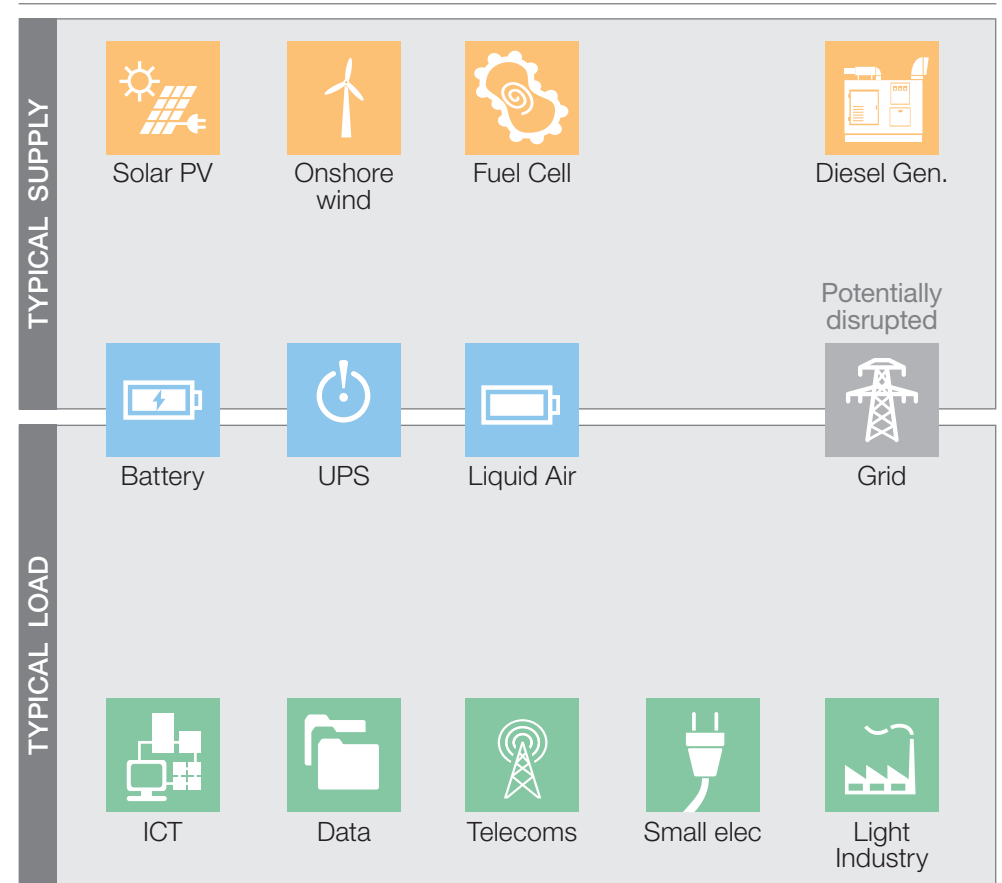
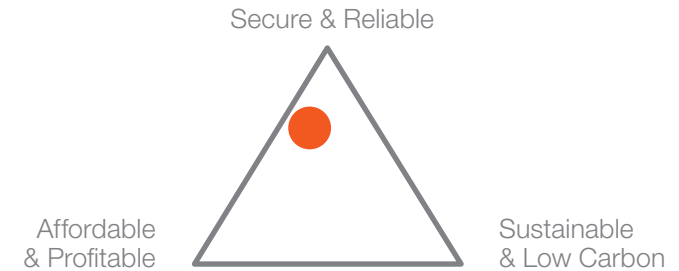

(μG) Applications – Intentional Islands

- Distribution Warehouse Complex
- Water Treatment Works
- Military Camp
- In-port Ship Supply

Certain clients gain commercial benefit from maximising the use of their indigenous renewable or other generation capacity. Others are forced to be independent and secure by virtue of their circumstances and operational needs, for example military camps.

In these situations the amount of renewable energy which can be generated as well as used within the clients boundary can be optimised through deployment of a microgrid. The ability to modulate load through DSR or energy storage in response to fluctuations in response to predictable intermittency (eg: PV) or unpredictable intermittency (eg: micro or onshore wind) means that maximum renewable energy can be used on site.

In some instances, there is a ‘time-shift’ mismatch between the diurnal generating pattern of certain renewables and the demand profile. For example a warehouse may operate 24 hours a day with a relatively modest load demand, but PV units mounted on its extensive roof space provide peak supply in the middle of the day. Smoothing this supply over the full day, while perhaps also drawing off peak energy from the grid brings maximum benefit.

Increasingly docked ships are required to use ‘clean’ onshore supplies rather than onboard generators and would benefit from a microgrid arrangement to reduce to cost and carbon footprint of the supply.

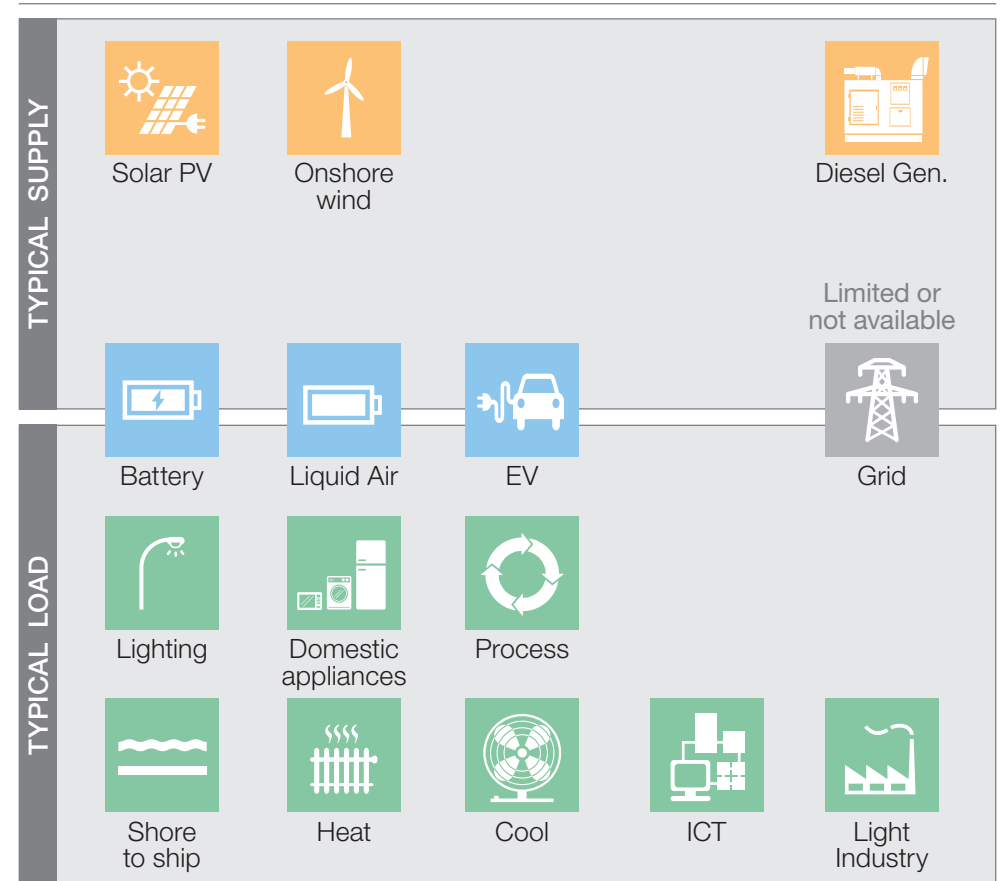
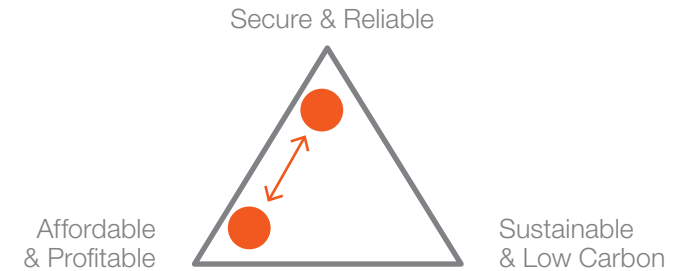

Comparing Benefits of AC and DC

There are advantages and challenges associated with the use of AC, DC or hybrid microgrids. AC systems are the most common, followed by DC, while High frequency AC (HfAC) applications tend to be found in aircraft or similar applications, but are beginning to enter the mainstream.

Key Benefits

AC Microgrid

Plug-in approach for all Distributed Energy Resources (DER)

Well developed interconnection, products standards and codes

Familiarity with design of AC LV electrical systems

Hybrid Microgrid

Suitable for applications where AC and DC power is produced and consumed

Similar benefits to DC microgrids

DC Microgrid

DC produced/stored by PV systems, fuel cells and batteries

DC used by increasing number of electrical devices

Lower conversion requirements

AC to DC conversion is easier and cheaper than DC to AC

Reduction in number of devices required (e.g. batteries chargers)

Energy savings around 5-15%

Improvement in reliability as there are less points of failure

Suitable for Zero-net Energy Buildings

Suitable for data centres

Addressable Challenges

AC Microgrid

Increased conversion requirements from DC to AC and back to DC

Energy losses in the conversion

More equipment and devices are required

Hybrid Microgrid

Control of the system is a challenge

DC Microgrid

Lack of existing applications for DC LV distribution systems

Current lack of approved standards and codes for DC LV equipment, distribution systems and microgrids

Lack of familiarity with design of DC LV distribution systems

Lack of approved/recognized DCLV system architecture (e.g. common bus collecting and distributing power)

Different safety and protection practices compared with AC LV distribution systems

Infrastructure upgrade required from AC to DC systems

Solutions to Technical Challenges

Power Quality	Grid Synchronisation	Microgrid Control
<p>AC Power Quality disturbance adversely affects both system voltage and frequency through voltage notching, voltage fluctuations, harmonic distortion, transients, flickers, outages and other variations.</p> <p>Sensitive demand groups such as data centres, communications networks, hospitals, high tech manufacture, financial trading and research laboratories are particularly impacted by poor Power Quality.</p> <p>Lawrence Berkley National Laboratory estimated in 2006 that customer losses associated with Power Quality events reached \$US79 billion per year.</p>	<p>Seamless control of system voltage and frequency stability within acceptable limits during grid connection or disconnection requires careful attention.</p> <p>Microgrids have particular technical requirements, especially if they include many different generation and load types, each with different response time, inertia and control characteristics.</p> <p>Transition between islanded and grid-connected mode also requires the microgrid generation to be correctly synchronised with the grid, ensuring safe and reliable reconnection.</p>	<p>Control architecture must be able to coordinate the generation, storage and loads, taking into account the various characteristics of each of the microgrid components.</p> <p>In parallel, control is required to achieve desired microgrid features including high power quality, low carbon/cost dispatch, CHP balancing, demand side response, supply/demand time shift and compliance with grid connection agreements.</p> <p>The suitable selection and configuration of control architecture is critical in the achievement of necessary real time system responses.</p>
<p>Microgrids can be designed and controlled to ensure premium Power Quality in line with consumer needs while also disconnecting or 'islanding' during grid power loss to maintain supply to local consumers.</p> <p>Power electronic converters can be used to provide harmonic compensation, while other control methods can be used to maintain other power quality parameters within required limits.</p>	<p>Seamless grid disconnection is achieved by control damping of any transients, while also engaging fast response storage to counter power imbalance.</p> <p>Control and instrumentation systems ensure that microgrid voltage and phase angle are aligned with grid before live or 'active' reconnection. Alternatively, the microgrid can be de-energised before reconnection and need not be synchronised.</p>	<p>There are two common control architectures.</p> <p>The Hierarchical approach divides tasks into Primary, Secondary and Tertiary under a master controller but has single point failure risk.</p> <p>The alternate Multi-agent approach is technically more complex, but is inherently resistant to single point failure.</p>

For more information
please contact:

microgrid@arup.com
energy@arup.com

www.arup.com

ARUP

