

THE ARUP JOURNAL

2/2003



ARUP

Arup is a global organization of designers. It has a constantly evolving skills base, and works for local and international clients throughout the world.

We shape a better world.

Front cover:

The Robert and Margrit Mondavi Center for the Performing Arts, UC Davis, California (pp32-41) © Jeff Goldberg/Esto

3

Delivering Laban's creative vision

Jane Foley
Rob Leslie-Carter



Merin Henry & Martin Rose

Editorial

Projects from four continents feature in this issue of *The Arup Journal*. They cover a wide range of human needs and activities, including the arts, sport, leisure, commerce, industry, healthcare, education, accommodation, communications, and sustainability. Within all there is the potential and capability to 'shape a better world'.

Arup is a member of the multi-disciplinary SANE (Sustainable Accommodation in the New Economy) consortium formed to examine the parameters involved in designing a 'workplace of the future' (pp55-58). In London, the new Arup-engineered HSBC bank headquarters provides a state-of-the-art working environment for 8000 employees on reclaimed brownfield Canary Wharf lands east of the City (pp10-19). At the opposite end of the locational spectrum, to 'touch the earth lightly' was the design goal for the Singita Lebombo tourist facility in Kruger National Park, South Africa (pp59-63). Arup's structural design contributed to a resort that impinges not at all on its unspoiled environment, and which will be returned to nature at the end of its 20-year concession period.

'Touching the earth lightly' also describes both the artistic goals for and the built presence of the award-winning Laban Dance Centre in south-east London (pp3-9), which includes a grassed roof designed to encourage the presence of rare birds. Apart from its environmental aspects, Laban is recognized as a catalyst in the renewal of this under-resourced part of London. Similarly, the transformation of The City of Manchester Stadium from host to the 2002 Commonwealth Games (see *The Arup Journal*, 1/2003) to a permanent home for Manchester City FC (pp47-51) is intended to trigger regeneration initiatives in this part of East Manchester.

The Robert & Margrit Mondavi Center at UC Davis, California (pp32-41), is the latest major arts centre engineered by Arup's USA practice; similarly, the Simmons Hall residential block for MIT (pp42-46) continues the firm's portfolio of sustainable projects for American universities. Arup Australasia's burgeoning consultancy activities now include sustainability advice on clients' own processes, as exemplified by work for Investa (pp52-54). In such projects Arup helps clients to minimize adverse impacts on the environments in which they operate.

Finally, two highly contrasted jobs in the British Isles beyond England: The Maggie's Centre (pp29-31), overlooking the River Tay at Dundee, Scotland, creates a friendly environment in which people with cancer can come to terms with the disease; it is the first building in the UK designed by Frank Gehry. At Cork in Ireland, safety and sustainability considerations were high priorities in the design for the latest addition to the series of organic synthesis manufacturing plants for Pfizer Ireland Pharmaceuticals (pp20-28) engineered by Arup's Irish practice.



Andy Ryan

42

Simmons Hall, MIT

Julian Astbury
Leroy Le-Lacheur
Mark Walsh-Cooke

10

The HSBC headquarters, Canary Wharf, London

Dave Choy
Faith Wainwright
et al



Arup



Denis Gilbert/VIEW

47

Transforming The City of Manchester Stadium

Martin Austin
Stephen Burrows
Darren Paine
David Twiss

20

Pfizer OSP4, Ringaskiddy, Ireland

Sean Clarke
Andrew Nixon
Hugh O'Dwyer



Janice O'Connell



Investa Property Group

52

Sustainability: Adding value to Investa Property Group

Katharine Adams
Cathy Crawley
Georgina Legoe

29

The Maggie's Centre, Dundee, Scotland

Forbes Winchester



Dave Robertson



Central

55

SANE: Designing tomorrow's office

Tom Fernando

32

The Mondavi Center

Peter Balint
Bruce Danziger
Paul Switenki
John Worley



© Jeff Goldberg/Esto



Linda Ness

59

Singita Lebombo

Alistair Avern-Taplin
Linda Ness

Back cover:

The HSBC headquarters, Canary Wharf (pp10-19)



Delivering Laban's creative vision

Jane Foley
Rob Leslie-Carter

Introduction

Laban is Europe's leading centre of excellence for professional contemporary dance training. Named after Rudolph Laban (1879-1958), the Hungarian dancer, choreographer and teacher, the school was established in 1953 and now trains some 400 professional dancers and choreographers from all over the world. Its award-winning new building in South-East London is the world's largest purpose-built centre for contemporary dance.

In 1999, Arts Council England awarded Laban £12.5M of National Lottery funding, enabling plans for the new £25M building at Deptford Creekside to proceed. Designed by the Swiss architects Herzog & de Meuron, it has become one of the most successful capital arts projects in recent years. The building explodes with colour, both inside and out. The façade consists of transparent or translucent glass, with coloured polycarbonate panels mounted in front of the glass to protect against sun, glare, and heat radiation. The shadows of the dancers inside the studios fall onto the matt glass surfaces of the interior walls and create a wonderful effect.

Laban houses 13 dance studios, a 300-seat theatre purpose-built for contemporary dance, offices, study rooms, and a dance health centre with extensive pilates facilities to support Laban's pioneering work in dance science. It also has a library and cafeteria open to the public. Activities in the new building are concentrated on two main levels: the large dance theatre, the heart of the Laban organism, is in the centre of the building on the first floor, whilst the upper storey houses most of the dance studios, interwoven along the lime and magenta corridors, creating a busy sense of community. Altogether Laban provides a thriving and vibrant centre for dance at national and international levels, and its presence in Deptford has begun an exciting process of local social and cultural regeneration. Arup acted as project manager within Laban's client team throughout the project, co-located with the client first in its old residence until 2000, and then in its new location. The relationship Arup developed with the client's team has been, and continues to be, excellent - a key factor in the project's success.



2. Rudolph Laban.

'I cannot over-emphasize how delighted we are with the way Arup has managed this project.'

The input from the other Arup groups has also been great.'

*Marion North,
Principal
and Chief
Executive,
Laban*

History

In 1995, with its existing building in New Cross becoming tired and cramped, and with local competitors upgrading, Laban knew that it needed to improve its facilities radically. The new building began as part of a vision shared by Marion North (then Principal of Laban and now Honorary Life President) and Anthony Bowne, (now Director of Laban).

Central to this vision was the belief that for Laban to augment its position as one of the world's pre-eminent dance centres, it needed to relocate to a high-quality, purpose-built space. The opportunity for a charitable organization to realize this vision was the potential for major funding through the National Lottery and Arts Council England. Laban wanted an architectural firm that could understand and interpret its vision, and translate this into an exceptional yet functional building. Herzog & de Meuron's now iconic design was selected after an international design competition in 1997, judged openly by a wide variety of stakeholders including the local community. Arup Acoustics formed part of the competition-winning team. Being unfamiliar with the construction process, Laban also needed specialist expertise to represent it and to make its vision reality. In November 1998, Arup Project Management was appointed by Laban as client project manager. Anthony Bowne commented: 'Arup did not come into the final round of interviews as favourites for the client project manager role. However, we were so impressed with the way the team came across straight away, we were unanimous that Arup Project Management would be the right choice for us.'

The firm's initial task was to secure the £12.5M lottery funding from Arts Council England necessary to give life to the project. Arup's project manager was responsible for delivering the entire funding application and managing inputs from multiple sources. As well as the design team, Arup selected, appointed and managed the consultants who developed the more strategic aspects of the document. This included the business planning and financial viability, the marketing and audience development, and the IT concepts for delivering the changes to Laban's educational and technical capabilities.

After competitive tender, Arup Economics & Planning was appointed to produce the client's business plan, and Arup Communications to define the client's information technology requirements.

The successful bid was one of only five awards over £10M granted in 1999. The project management was subsequently described as 'exemplary' by Arts Council England, and the bid documents prepared for the original funding application have been recommended by the Council as a best practice guide for future applicants.



3. The striking bands of colour are now synonymous with the dance studios; the glass selected ensures glare is controlled without reducing daylight.

Mobilizing Arup resources

Acoustics

Laban was very clear about its acoustic brief from the beginning. The existing buildings at Laurie Grove, New Cross, had grown organically. Studio spaces in the old extended church, as well as being restricted in dance area, were very reverberant, suffered poor sound separation from adjacent areas, and had noisy ventilation. In contrast, however, the building was obviously a hive of activity.

Sound from the new studios needed to spill out into the circulation spaces to create a feeling of vibrancy and community in the building, but equally this had to be balanced with ensuring that activities in areas such as the lecture theatre or the library were not disturbed by music or dance impacts.

Arup Acoustics further ensured that the acoustic response of each studio would support good speech intelligibility and definition of the music or soundtrack, with background noise levels strictly controlled. Each of the 13 studios was designed to have a different form, size, shape, light, and acoustic response. The studios all have irregular shapes, with one wall either convex, curved or angled in plan. The ceilings are exposed concrete slabs with a deeply ribbed profile that, on the first floor, slopes to follow the roof profile. Each of these features acts to scatter the sound in the space; however the non-parallel walls prevent the occurrence of 'flutter echoes' that dance studios often suffer from. Design of the studio walls and floors was driven to be as cost-effective and to fulfil as many functions as possible. The walls are deep twin-walled plasterboard constructions, as used to divide multi-screen cinemas, but also incorporating ventilation, storage and loads from mirrors and ballet bars.

Instead of high load, high cost floating concrete slabs for the floors, only the screeds were floated to isolate the impacts from the dancers.

The 300-seat theatre is used for dance performances, accompanied by either recorded music or live musicians, the acoustic controlled and intimate. However, as with the studios, the absence of noise in performances is very important for dramatic effect. This was achieved with a heavy concrete structure for the auditorium shell and a low noise, underseat displacement ventilation system.

Despite all these demands, the acoustic design was able to meet the functional acoustic requirements to ensure effective teaching, while retaining a lively feel in the building and respecting the architectural concepts.

The strength of technical support that Arup could muster contributed enormously to the project's successful management. As part of a design-based firm, the project management team was able to harness this knowledge base extremely effectively. The diversity of Arup's wider contribution to the project greatly assisted this central role, enabling the project manager to offer Laban a complete strategic, management and technical consultancy.

Business planning and taxation advice

Arup Economics & Planning was appointed to develop the detailed business plan including economic and regeneration benefits, and to provide taxation and VAT advice. A robust projection of Laban's future financial performance in the new building was prepared, and Arup also led negotiations with HM Customs and Excise, agreeing the best approach for Laban to become VAT-registered, allowing it to recover £1.9M worth of VAT over the life of the project.

The firm was subsequently appointed to provide specialist town planning advice to Laban, reviewing proposals for several major adjacent developments. Arup's input ensured that these proposals were modified to protect Laban's unique daylight requirements.



IT and communications

Arup Communications was appointed in March 1999 as IT consultant. Working with the client's IT representative, Arup developed a strategy and design for delivering state-of-the-art telecommunications facilities for the staff and students.

Strict budget constraints applied, so key to the success of this project was not only to identify the most appropriate technologies but also to deliver partnerships with technology providers who could augment the skills of the Laban team.

Rather than produce a detailed design for the data network and information systems, Arup worked with the client's existing computer and network supplier. This allowed the supplier to develop his own scheme design into a design proposal for supplying and installing data network equipment, PCs and information systems, ranging from basic office automation packages to specialist software such as student management and timetabling. Arup Communications advised Laban on the technical aspects of the proposal put forward and validation of the costs associated with it.

Throughout this process the firm provided a combination of day-to-day technical advice with regular management briefings on IT issues.



Whole life-cycle costing

As part of the outline business case to secure project funding, a forecast had to be made of the operating, maintenance, and major refurbishment costs for the new facility. Arup Facilities worked closely with other parts of the project team and the client to interpret the high-level design information available at the early stages of the project. This information was used to forecast these costs, and provide essential budgetary information for Laban.

During the progress of the project, Arup Facilities reviewed the document at key stages to update and enhance the base data. The life-cycle model created was a 'living document' that allowed unlimited future development and refinement by the client, and formed the basis of an essential management tool, allowing the modelling of future expenditure and equipment replacement cycles. Arup Facilities remain involved with Laban, providing ongoing advice and support to its maintenance strategy.

Lighting

The natural and artificial lighting design for Laban was a collaborative effort between the artist, Michael Craig-Martin, the architects, the electrical engineers, and Arup Lighting, whose main role was to give specialist advice to the client and architect for daylighting and for some of the more unusual electrical lighting systems.

From the outset, a key design intent was that all the dance studios should be naturally lit. Natural lighting provides visual interest, allows for a high quality lit environment for the students, and offers an economical solution for illuminating the spaces. However, the use of daylight raises certain issues like glare, and these had to be addressed in the design.

Arup Lighting made several detailed studies on the façade, including computer analysis, scale model tests, and a half-scale mock-up of a typical dance studio on site (Figs 7 & 8). The system developed from these studies gives sufficient but not excessive daylight in the dance studios, and eliminates glare from the incoming daylight. The selection of light-admitting materials, and their special relationship with the internal spaces, was carefully assessed to create a good balance of daylight and electric light, and to ensure that the spaces remain usable all year, with no need for active shading elements.

In addition, the team in the studies carefully considered the façade colouring, striking a balance between the colour adding character to each space (and to the external appearance of the building), but not being so strong as to affect significantly the appearance of people and objects in the studios.

Environmental and sustainability advice

Arup Environmental advised Laban throughout the project. After proposals for the environmental input to the proposed gas remediation of the site were challenged by Arup's project manager, Arup Environmental was commissioned to recommend a simpler alternative solution. The team's proposal saved the contractor four weeks on site and reduced costs by £60 000.

Arup also provided contamination and biodiversity input to the maintenance strategy for Laban's garden. This input helped get the landscaping proposals approved first time by the local authority and environment agency.



7. The team discuss options for the internal glazing and polycarbonate inside the half-size studio mock-up.



8. Exterior of half-size studio mock-up.

Managing the project

Laban is the first such project in which so many Arup specialist groups have come together for a single client. Also, centred around the core role of client project manager, it became clear that Arup Project Management, Arup Economics & Planning, and Arup Communications could align to provide a complete strategic, management, and technical consultancy service for the entire project. The central project manager role ensured that Arup's combined service was integrated and well-targeted, and that the full spectrum of Laban's requirements was understood and effectively addressed.

As a result Arup could manage the entire project process, from establishing the initial business case through to the cultural change implications for the users moving into a new flagship building.

Providing a complete service from within the client team enabled Arup to think of its own activities and those of Laban, and Laban's clients, as interconnected. The project manager was sufficiently close to the client to be able to understand the requirements of the project funders and the board of directors. This close collaboration and trust allowed some activities that served only to over-control each other to be eliminated. Laban was able to remove the need for an independent client representative to monitor the project manager, which saved the project £0.5M. Equally, Laban's senior management team was confident enough to be able to focus on the operation of the school during this period of intense change, rather than on the construction project. The management structure provided Laban with a single point of responsibility for delivering the project, and also maintained clear lines of communication throughout the team, allowing direct contact with the client when necessary.

Two-stage tendering

As part of the Lottery funding bid, Arup's project manager produced a strategy report advocating a traditional procurement route, given the bespoke nature of the building and the quality and price certainty required by the client and funders. But, due to a five-month delay in the grant award, it became clear that the start and completion dates would not be met using this route.

The 2 September 2002 completion date was set in stone, since Laban were only able to relocate whilst ensuring continuity for students during a summer holiday period. Missing the date would potentially have caused a delay of 12 months until the following summer.

In discussion with the stakeholders, the strategy was changed in two ways. First, the single building contract was split into three, with the demolitions and remediation (Contract 1), and the piling (Contract 2) awarded separately from the main building construction (Contract 3). Secondly, an innovative two-stage procurement route was developed that would allow the main contractor to be appointed and start on site early enough to meet the completion date, and to allow sufficient time to complete the detailed design.

As a result, the momentum of the project was maintained, work commenced on site as planned, and the completion date was met. This procurement process proved very successful for Laban and is now being used on several other Arup projects.

The project team

Effective management and leadership skills from the project manager were of fundamental importance. From the outset, the team understood that timescales were very short and to achieve success, its members needed to develop trust and be prepared to work together. In the early stages of the project, Arup set up workshops with the client, design team, main contractors, and individual subcontractors. While these workshops had formal objectives they also created an integrated team, and ensured that everyone understood the objectives and their role in achieving them. These regular workshops continued throughout the project, providing an informal yet effective forum to address key issues.

The procurement route used, involving the early appointment of the main contractor, depended upon this well-integrated team. The excellent relationship engendered between the contractor, subcontractors, and design team was sustained throughout and clearly contributed to the project's success.

The contractor being able to participate so early meant that packages could be value-engineered quickly - indeed some £2.5M of value engineering was achieved on the project. The project's final account was agreed within a month of practical completion.

The stakeholders

As with many publicly-funded projects, Laban had numerous stakeholders:

- the client
- the project team (over 100 individuals representing 22 separate consultancies)
- multiple funders from both the private and public sectors
- over 400 students and 100 staff
- highly vocal and well-respected community and environmental groups
- the local community.

Arup's project manager was the single main point of contact for the entire spectrum of stakeholders, with whom enormous trust and respect was developed throughout the project.

This was facilitated by establishing a project extranet site that increased the speed and efficiency of communications for the international project team, and made project information accessible to all, including schools and the wider local community.

9. Reflections in the glazed façade.

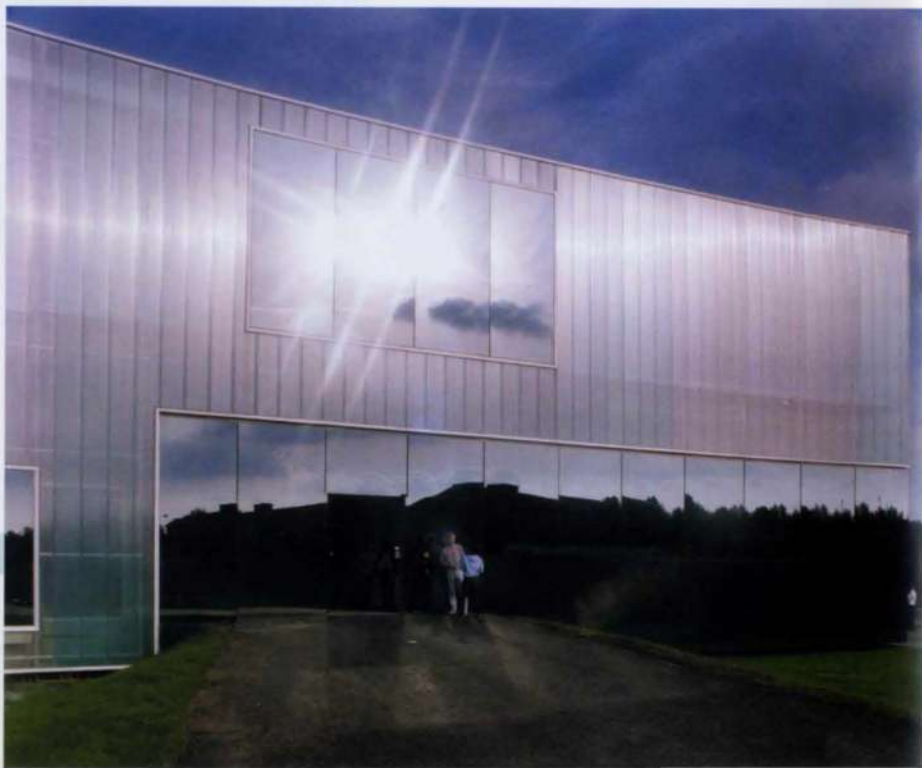

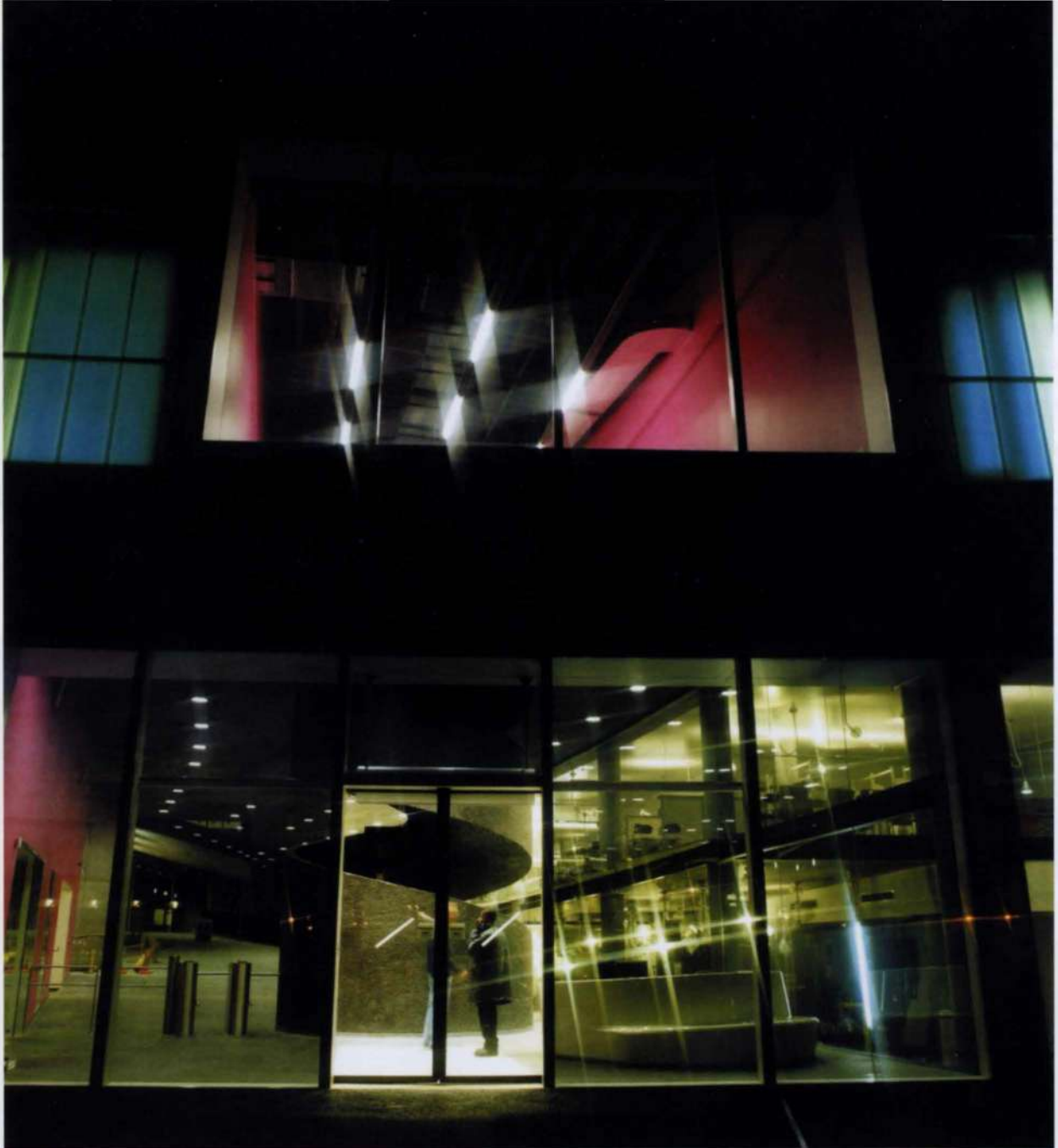

10. The colourfully lit interior seen through the outer glazed panels.

Arup's stakeholder management success is illustrated by the close work undertaken with local environmental and biodiversity groups, which helped to ensure the inclusion of a green roof above the stage area that provides a protected and undisturbed habitat for the endangered Black Redstart bird.

Arup was subsequently invited by English Nature to give a presentation at the launch of a local biodiversity website, explaining the opportunities for sustainability in major building projects, and the benefits of green roofs.

Arup's project manager also developed a very strong relationship with Arts Council England, a principal funder in the project. Delighted with its success and wishing to see it completed in line with the client's ultimate vision, the Arts Council granted Laban additional funds to complete landscaping works that previously lay outside the available budgets.

Clearly, there were major benefits to the project of fully engaging with these stakeholders. The project received their full support throughout, including the outline and detailed planning applications, which were unanimously well-supported and unopposed.

11. Laban's green roof: a protected and undisturbed habitat for the endangered Black Redstart.





Feedback

Most significantly, the students and staff at Laban love their new building. Anthony Bowne comments: 'The new centre hits all our targets. The students love it and we are delighted to be teaching in such a visually-exciting building. It gives us exactly the quality of space and personality we need for dance practice and performance; we opened on time and our limited budget was managed extremely wisely. The centre is a great inspiration for the local community.'

Laban has also been praised by Joan Ruddock, the Member of Parliament for Lewisham, for acting as a key focus for the physical and social regeneration of Lewisham and the Thames Gateway. It is also proving a catalyst for the development of the cultural and creative industries in Deptford and South East London. On its open day in February this year, 6000 visitors from the general public queued to see Deptford's new cultural landmark.

13 & 14. Typical studio, below: showing the bar along the mirrored wall, and right: in use for dancing practice.



15. Showing the effect of coloured panels on the façade.





Credits

Client:
Laban

Project manager and specialist consultants:
Arup
Chris Barrett, Andy Bascombe, Volker Buscher, Helen Butcher, Joanna Chambers, Paul Craddock, Daniel Davis, Allan Delves, Rob Evison, Rob Harris, Mario Kaiser, Joanna Kennedy, Rob Leslie-Carter, Malcolm Lowe, Don Oeters, Richard Owen, Nigel Quick, John Rose, Jeff Shaw, Mueed Sheikh, Vaughan Sutton, Barry Walker, Sally Wells, Paul Whitehouse, Simon Wright

Architect:
Herzog & de Meuron

Structural and building services engineer:
Whitby Bird

Quantity surveyor:
Davis Langdon & Everest

Theatre consultant:
Carr & Angier

Illustrations:
1, 4, 5, 14: Merlin Hendy & Martin Rose
2: The Laban Centre
3, 16: ©Arup/Helene Binet
6: Dennis Gilbert
7, 8, 11: ©Arup
9, 10, 13, 16: ©Arup/Countrywide Photography
12: Ralph Cox
15: Dennis Barker

Conclusion

Laban's staff moved in on 2 September 2002, the exact date set at the start of the project, four years earlier. The building rapidly became an architectural icon, winning awards including the 2003 Stirling Prize for Architecture and the Royal Fine Arts Commission Trust Award for 'Dance Building', as well as a High Commendation in the British Construction Industry Awards. For his project management role, Arup's Rob Leslie-Carter was declared 'Project Manager of the Year' in the Association for Project Management Practitioner Awards, with the building itself Runner-Up in the 'Project of the Year' category.

At the official opening ceremony in February 2003, Gerry Robinson, Chairman of Arts Council England, praised the project management as 'exemplary throughout', and Arts Council England subsequently put Laban forward for its 'Client of the Year' Award.

Ultimately, Arup provided Laban with a truly complete management service. The success of the project exemplifies the fact that effective project management brings about teamwork, shared enthusiasm, and an end result that satisfies client and team alike.

16. View into Laban through glazed panelling.



'Having Arup acting full time inside Laban's client team proved exceptionally useful for ensuring lines of communication between the Arup groups and the client were minimized.'

*Anthony Bowne,
Director, Laban*

The HSBC Headquarters, Canary Wharf, London

Introduction

The new group head office building of HSBC stands proudly in the vibrant business district of Canary Wharf, East London. Some 8000 employees occupy the 210m tall tower, making full use of the building's extensive range of facilities and services.

The decision to build a new headquarters at 8 Canada Square dates back to the mid-1990s when HSBC began a search for new premises to unite its thousands of staff in buildings across the City of London. The objective was clear: an HQ appropriate for one of the world's largest banking and financial services organizations.

Between 1995 and 1997, various options were considered, including redeveloping the former group head office at 10 Lower Thames Street in the City of London. However, only the Canary Wharf estate could provide the standard of location and volume of space necessary. Furthermore, there was the opportunity to complete the building quickly as planning permission for the estate had already been granted. In early 1998 a heads of terms agreement was reached for a 45-storey building to occupy Canary Wharf's DS2 plot, alongside the UK's tallest building at 1 Canada Square. The new building has four basement levels, five levels in the 75m square podium, and 40 floors above, each 56m square.

HSBC had successfully developed its Hong Kong headquarters building at 1 Queens Road Central in the early 1980s¹ with Arup, Foster and Partners as architect, and quantity surveyors Davis Langdon Everest. Nearly 20 years later HSBC appointed the same team for its global headquarters, with Arup providing multidisciplinary engineering services including fire, building management controls, acoustics and security design. An HSBC in-house project team was set up to ensure that all the bank's requirements would be met. In collaboration with Canary Wharf Ltd's strong development team, an unusually fast-track development for a building of this size was undertaken and successfully executed.

An additional challenge stemmed from the fact that shell and core work would overlap with fitout, under different management teams and conditions of contract. The shell and core was a design-and-build contract with Canary Wharf Contractors Ltd as contractor and the Arup/Foster design team. For the fitout Canary Wharf was the management contractor, with trade contracts being placed directly by the client. During the last year of construction, the design team co-located onto a level of the new building while the fitout works were being completed. The result reflects the enthusiastic collaboration that took place on the project, delivering a highly cost-effective design with state-of-the-art facilities and finishes.

Construction

Construction began in January 1999 with the boring of the building's substantial deep pile foundations. During spring, the concrete core rose steadily with approximately 100 workers on site each day, increasing monthly by several hundred to over 1000 at the end of 1999.

The tower began to assume its current appearance in summer 2000 when work started on installing the 4900 glass panels. As the base build continued on schedule, early 2001 saw work begin on the fitout, including installation of services to the 850-seat staff restaurant and health club. In March 2001, bankers, journalists, contractors, and the design team gathered for topping out, as the final steel girder was hoisted to the top of the tower.

Within weeks another milestone arrived, as the giant hexagonal HSBC corporate signature was installed on all four sides of the building's crown. In early 2002, with the base build completed, the project moved to the final stages of the category B fitout; installation of carpets, desks, and other furniture.

By this time, the number of workers on site had risen, with up to 1700 on duty each day. The first HSBC employees began work in the new building at 8 Canada Square on 2 September 2002, marking the culmination of seven years' planning, teamwork, and commitment from all involved. The phased occupation of the building was completed in February 2003 when the last of over 8000 staff moved in, with HSBC Group Chairman Sir John Bond officially opening the building as the Group's new head office on 2 April 2003.

Graham
Aldwinckle
Dave Choy
Paul Cross
Barney Jordan
Faith Wainwright



1. View of the completed HSBC tower.

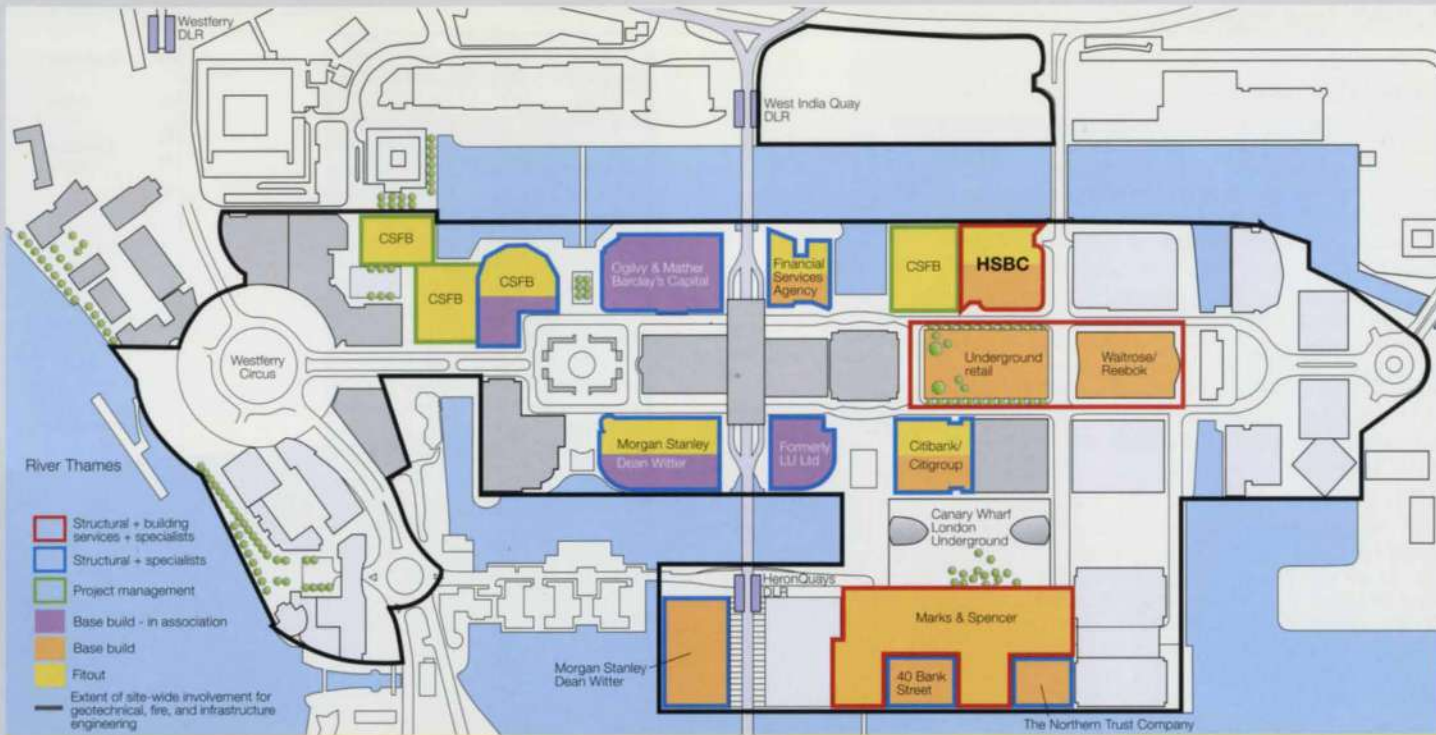

2. Site plan showing major tenants and the extent of Arup services.

The Canary Wharf location

John Brazier

Arup has been involved in Canary Wharf² in London's Docklands from the start in 1985, when G Ware Travelstead and a consortium of American banks proposed a new financial district there. Olympia & York took over the development in 1987 and this drove the proposals to reality. Phase 1 was built between 1987 and 1992, with Arup providing local knowledge and input to a largely American design team.

Arup's involvement in Phase 1 was:

- engineer for the enabling works, including demolition, dock wall stabilization, site investigations, and pile testing
- geotechnical consultant for most of the Phase 1 buildings
- structural engineer for the foundation platform built in the dock for four of the Phase 1 buildings
- structural engineer for one of the buildings, also in the dock, currently occupied by the Financial Services Agency
- engineering advice on the design of the temporary cofferdams for Phase 2 buildings
- engineering input into the masterplan for Heron Quay, now known as Canary Wharf South.

Olympia & York went into administration in 1992 and Canary Wharf Ltd (CWL) took over ownership of Canary Wharf, although many of the key management people remained unchanged. Between 1992 and 1996 CWL gradually let space and also marketed its Phase 2 sites. Arup involvement during this period comprised structural engineering advice on the fitout of Phase 1 buildings and assistance in assessing schemes for Phase 2 sites for potential tenants.

Sustainability aspects

The Canary Wharf estate is built on brownfield land and reclaimed land, and is served by its own dedicated Jubilee Line Underground station. This ensures that around 90% of journeys are made by public transport. The estate is also extremely large, around 35ha, with 1.2Mm² of lettable space already built and a further 100 000m² under construction. It has copious high quality open spaces for the amenity of the users of the buildings.

For the HSBC building's structure and services, flexibility in use was designed in, including allowance for a potential further floor in the podium. Before the first piece of earth was moved at the site, HSBC's commitment to the environment was tested against building guidelines from

Phase 2 of Canary Wharf was unlocked when Citibank chose it as the home for its new building in 1996. Arup had been working with architect Foster and Partners to assess sites for Citibank and as part of the deal the consultant team was taken over by CWL to design the building to meet Citibank's requirements. Canada Square Park to the north of Citibank, as well as associated roads and utilities, had to be built to serve the Citibank building.

The park has one level of retail and three levels of car parking beneath, and Arup was structural, geotechnical, building services, infrastructure, fire and security engineer for this development.

In 1998 the HSBC took the DS2 tower site for its new headquarters, a deal quickly followed by others with major tenants, many of them financial, which has realized the original concept of Canary Wharf as a new financial centre for London.

Subsequent to HSBC, Arup has been structural and building services engineer for two major retail developments and structural engineer for three more office blocks. In addition, the firm has secured site-wide commissions for geotechnical engineering, fire engineering, and infrastructure engineering, as well as other specialist commissions for security and façades.

Arup has also provided input into the design of fitouts for several tenants, the most significant being the fitout of the four buildings that Credit Suisse First Boston occupy.

From the initial provision of some structural and geotechnical engineering advice on local practice, Arup's role has grown over the years until now the firm is one of the major consultants working on Canary Wharf, providing a wide range of services.

the UK government-funded body BREEAM. Management of the building, energy and water use, and health and comfort issues were all assessed, as were the choice of materials, land use, pollution, and ecological issues. The assessors gave HSBC a good rating, acknowledging that harmful materials had been avoided and that many environmentally-friendly features had been incorporated.

These include energy reclaim, treatment of kitchen grease, use of copper silver ionization to prevent bacterial growth in domestic water, and highly efficient façades with internal blinds. HSBC played its part in implementing a refuse compactor installation, reducing paper storage within the building by 70%, and installing its water bottling plant.

HSBC key features

Reception (ground floor)

With minimalist overtones, the spacious ground floor reception area (Fig 8) combines back-sprayed black glass and grey granite flooring to create a fine first impression for visitors to HSBC's new HQ. TV monitors carry rolling news feeds and a digital information board. The illuminated ceiling simulates an open natural environment which, combined with the spaciousness, feels almost like being outside.

The lighting has over 3000 luminaires, suitably positioned for even light spread. The heat generated by them and the control gear necessitated a system where return air provides cooling to the light boxes to ensure that colour, temperature, and efficacy are not affected, as well as ensuring a reduction in dust settlement. Where return air-cooling could not be achieved, direct cooling is provided by recirculating chilled water fancoils within the ceiling.

Lifts

From the entrance, four banks of lifts are accessible, serving levels 1-15, 15-25, 25-34, and 34 to the roof. Levels 15, 25, and 34 are therefore known as 'transfer floors', as to access level 29 from level 20, for example, you would travel to level 25 and transfer to another lift. The lift arrangements were a critical part of finalizing the concept for the building as they largely dictate the structural form of the core and the vertical zones for services.

The 'History Wall' (ground floor)

Unveiled in September 2002, HSBC's 6.6m high 'History Wall' (Fig 15 in Fire Safety panel on p18) marks the history, achievements, and values of the Group from the 18th to 21st centuries. Located in the ground floor lobby and designed by the Thomas Heatherwick Studio, it boasts 3743 captioned images including documents, photographs, portraits, and illustrations of staff, buildings, businesses, and events. They are arranged so that when viewed from farther away a 'magic eye' effect becomes apparent, revealing the letters 'HSBC'.

Staff restaurant (level 1)

The 850-seat staff restaurant (Fig 6) is possibly the largest of its kind in Europe, serving some 2500 meals daily. A 450m² servery provides some 70m of counter space. To the end of the dining area and round to the left is a food bar with a 17m long continuous marble counter top. Light refreshments and tea/ coffee are served here with a seating area that overlooks the main ground floor reception.

Trading floors (levels 2-4)

The building includes a treasury, capital markets, and equities trading operation, all served by giant screens displaying order boards and pricing information. The treasury and capital markets operation over the whole of level 4 forms one of the world's largest trading floors, accommodating nearly 600 dealing staff and 1750 flat panel screens across 4500m² (Fig 5). HSBC is a leading player on international foreign exchange markets, offering a 24-hour capability with London connecting to the Group's other key dealing operations in New York and Hong Kong. Plasma screens hanging from the ceiling provide continuous market news. Equities trading and research take place on a separate floor, with settlements occupying the third large floor in the podium. The special IT requirements of the treasury and capital markets business had to be taken into account during fitout in early 2002, including the laying of some 800 000m of cable.

Health club (level 5)

This is a substantial facility with some 120 machines, 26 showers, steam rooms and saunas (Fig 4).

Client dining floor (level 6)

Accessed by two scenic lifts running up the building's east side, this floor provides 19 private dining rooms and an à la carte restaurant.

Training floor (level 14)

This includes five 30-seat conference rooms, all with audiovisual facilities, plus nine breakout rooms, six IT training rooms, and 10 small interview rooms.

Transfer floors (levels 15, 25, 34)

At each floor where people transfer between lift banks, there is a reception area as well as a café, shop, first aid area, cash machines, and meeting rooms.

Level 15 houses medical and dental suites.

A personal banking centre on level 25 provides a range of services for staff.

Level 34 hosts a large marketing suite.

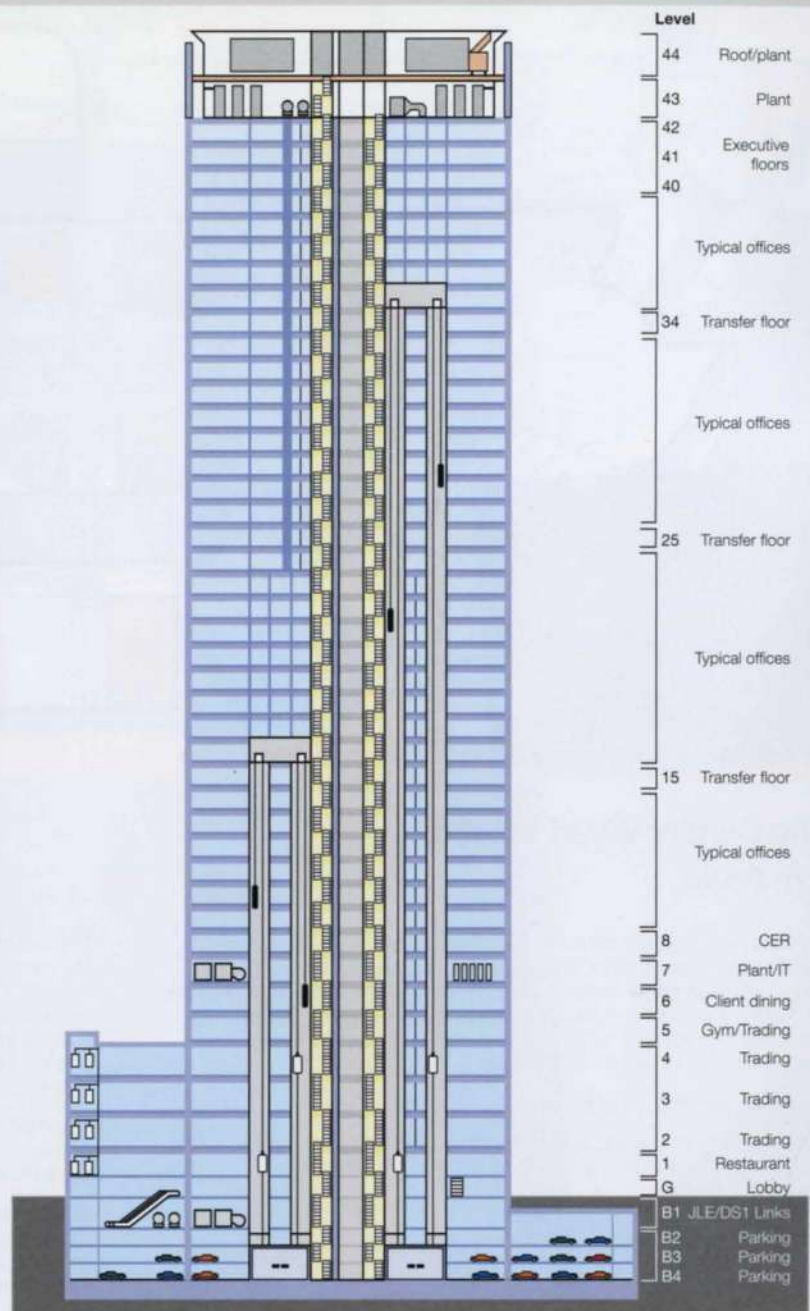

3. Elevation showing the 44 levels.

Central and satellite equipment rooms (level 8)

The central equipment room (CER) is the building's nerve centre. Occupying all of level 8, it contains the complete IT equipment required to run the building, as well as the main local computers and networking equipment that support data, voice, and video services. The two exchanges that operate the building's 10 000 telephone extensions are also here. Each floor also has pairs of satellite equipment rooms (SER), from which communications and IT wiring emanate to serve all the floor's desktops. Each SER has its own standby electrical supply as well as its own dedicated close control air-conditioning unit. Over 700 IT cabinets house equipment that required the laying of some 2Mm of cable.

Main plant floors (levels 7 and 43)

Air-handling plant is divided between these two floors. The AHUs supply treated air into a structural shaft that runs the height of the building. Level 7 also houses the plant that generates domestic hot water from gas-fired boilers to serve the level 5 gym changing facilities and the level 6 and level 1 kitchens. Also at level 7 is the uninterrupted power supply (UPS) system, which provides an instant standby electrical supply to serve the level 8 CER and the SERs throughout the building.

At level 43, access for the external 'Halo' specialist lighting for the crown of the building also acts as the air intake/exhaust for the level 43 AHUs. The crown lighting also incorporates HSBC's hexagon symbols on the four sides of the building just below the roof, with powerful backlights (Fig 7) to illuminate the brand at night.

Boardroom (level 42)

The impressive boardroom has state-of-the-art audiovisual facilities for presentations, videos, and conference calls. Beneath its double-height ceiling it boasts, across an entire wall, a huge world map created from two-tone aluminium strips and, from its vast floor-to-ceiling window, a panoramic view across London.

Roof (level 44)

The roof contains 14 closed circuit cooling towers, arranged as two separate heat rejection circuits to provide resilience to the building's operation. The tower pond water is treated by a silver copper ionization system that obviates the need for hazardous chemical handling and storage.



4. The gymnasium (level 5).



7. Crown lighting (at roof levels 43/44) for the HSBC symbol.

5 right. Trading floor (level 4).



6. Staff restaurant (level 1).



8. The spacious reception area (ground floor).



9. Base of chilled water risers (at B4 raft level).

Foundation design

Tim Chapman
Duncan Nicholson

Arup Geotechnics had been very involved in Phase 1 at Canary Wharf², so when Arup was appointed as structural consultant for the Citibank and DS2 buildings in Phase 2, there was a useful database of experience from which to draw. Plot DS2 for HSBC was the largest of the buildings and the first to be constructed in the north cofferdam.

Most of the Phase 1 buildings were constructed over the dock and founded on marine piles, which were relatively expensive and limited building heights. In 1992, two cofferdams were built to allow conventional piles to be used for the next six office buildings, and to provide basement space for car parking. They remained empty for almost a decade during the recession until a reinvigorated Canary Wharf put funding in place for Phase 2 of the development.

The foundations for Citibank in the south cofferdam were built in 1997 when the adjacent Jubilee Line station was nearing completion in its deep excavation. This had necessitated dewatering of the Thanet sand/chalk aquifer, and the Citibank piling contractor was able to take advantage of these drier soils to install his large diameter bored piles under bentonite much more quickly than expected. Canary Wharf and Arup Geotechnics saw the potential for speedier piling at DS2 and the subsequent buildings, and initiated a contract to continue dewatering of that deep aquifer. Dewatering from some six wells started in December 1998 and eventually a flow rate of 150 litres/sec was needed to draw the water level down to under -30m OD, below the deepest pile toe levels. Once the water level had dropped a flow rate of about 60 litres/sec was needed to sustain the lower water levels. Care needed to be taken that the cone of dewatering didn't cause any distress to the neighbouring buildings, including those owned by Canary Wharf. Maximum recorded settlements reached 13mm, but as the tilts were negligible, no damage of any kind was noted.

A load test to failure indicated that much higher pile capacities could be gained than conventional design approaches would allow. Accordingly, a new theory had to be devised based on fundamental soil mechanics theory to take this benefit. This was accepted by the District Surveyor and eventually published³.

338 permanent piles were installed by Keller Ground Engineering between January and July 1999 for DS2, including two to receive the south abutment for the Great Wharf Road Bridge planned for installation once the building was complete. These piles were generally 1.5m in diameter. They started with 8m penetration into the Thanet sand but this was reduced to 5.5m once the load test results had been interpreted and the new design method agreed. This reduction in pile depth bored was very helpful as it took the toe level above the level of the water table in the deep aquifer - still being reduced by pumping. This brought all the benefits of a relatively dry pile bore and accelerated the piling programme.

To maximize pile capacity the piles were base grouted, which involves injecting grout under very high pressure through pipes cast into the pile concrete. It makes the pile performance less reliant on the presence of any soft debris that may have accumulated at the pile base. The base grouting ducts were also used for checking the pile integrity by sonic coring. Some anomalies arose during base grouting and sonic logging but most were quickly resolved with no need for further site work. However, due to defects identified by integrity testing, three piles were sufficiently poor to need replacing and because of site constraints, six replacement piles had to be provided.

In terms of cost per tonne carried, these piles proved to be some of the most economical ever installed in London, with total costs approximately half of the equivalent for piling in the City or West End. The dewatering continued for all the Phase 2 buildings, and direct savings in pile costs more than paid for the dewatering, even ignoring the significant programme advantages. In all, Arup Geotechnics went on to design the foundations for all 16 building plots completed in Phase 2, a total of more than 4000 large diameter piles, as well as several bridges and public areas. The basic foundation design and construction principles established for the HSBC tower proved very effective on subsequent buildings.

10. HSBC tower pile test.

Programme and planning

For its magnitude, the project was designed and constructed remarkably quickly. The Canary Wharf team was geared to delivering buildings rapidly; with no planning permission stage in the process and the cofferdam already in place, there were no barriers to teams delivering construction information as quickly as possible.

Also, the previous involvement of Arup and Foster and Partners in the nearby Citibank building, as well as the overall site development, meant that the team could hit the ground running.

The planning had to fit in with established cost benchmarks and meet market expectations for high quality, flexible office space with a high degree of user comfort. This constrained the project team to provide an air-conditioned building with a central core, maximizing the development potential of the site and optimizing net-to-gross floor ratios (78% was achieved). Delivery demanded production of the most economical design possible, to raise values in every area from aesthetics to ecological performance.

The double-glazed façade has high-performance coatings to maximize heat reflection and fritting, with fixed internal blinds to reduce solar gain and glare. The building is fully air-conditioned but is highly energy-efficient due to a good thermal performing façade and energy recovery measures on the services. The central-core structure, the ceiling and services layout, and a highly flexible partitioning system were designed to allow HSBC teams to reconfigure with ease and speed. The building was to set new standards in the commercial office sector.



The project team rapidly geared up to full-strength working after appointment in October 1998, and a detailed multidisciplinary scheme design was produced by the end of that year. With a very substantial piling and dewatering contract to execute, piling began in November 1998, a mere four weeks after the appointment. Thereafter, design and construction went hand-in-hand, with the major structural packages confirmed on the basis of a set of drawings in April 1999 and phased release of reinforcement and detailed drawings.

The rapid construction of the concrete and steel contracts was helped by an excellent level of definition in the April 1999 drawings package, as well as the close working relationships from the outset and on through the whole project with the management contractors, Canary Wharf Contractors Ltd, and Cleveland Bridge and Byrne Brothers, respectively the steel and concrete contractors.

11a-d:
Self-climbing core formwork
construction sequence.



11a. December 1999



11b. July 2000



11c. December 2000



11d. July 2001

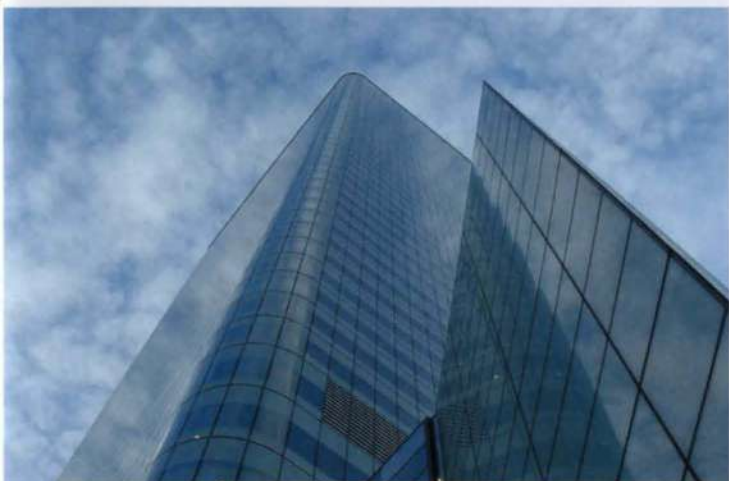

12. View up the completed HSBC tower.

Structural economy

As is usual with tall buildings, operations were fast-tracked, and the hybrid built form of a concrete core with steelwork floors and perimeter columns allowed erection to proceed rapidly (Figs 11a-d).

The project's strong collaborative framework allowed buildability issues to be anticipated and the structure's efficiency to be refined.

The core formwork was self-climbing, with one central tower crane rising with the core and perimeter tower cranes left free to lift the steelwork, the floors being constructed at the rate of one per week. To start the steelwork as early as possible, the steel columns begin at pile cap level, rising through four basement levels of concrete construction before the first steelwork floor at level 1, allowing erection of the steelwork superstructure to start before the basement was completed.

Basement construction

The basement floors are typically 300mm thick concrete slabs on a 9m x 9m grid. Deflection limits were chosen to be compatible with car park use rather than to British Standard *BS8110*, yielding savings for the client.

Plant requirements resulted in deeper structural depths and double-storey heights in places. The floors act as diaphragms, transferring horizontal loads from the ground on the south and the dock on the north to the core and the perimeter retaining walls. The latter are typically 600mm thick and designed as watertight concrete in accordance with *BS8110*, which allows some seepage.

Additional protection, by inner cavity walls and external protective treatment, imparts higher grade watertightness where required.

The car parking entrance and loading dock arrangements required just one column to be transferred out at a higher level. A notable feature of the basement is that the existing dock wall, a listed heritage structure, falls directly below the building's southern perimeter. All the columns on this face were thus transferred over the wall, with the transfer structures just below ground level. Thus, in theory, were the building to be demolished, the brick dock wall would again be visible. Apart from this, all vertical structure is continuous to the basement level.

The raft foundation - in effect the pile cap - is 3.15m thick below the core and 1.85m thick at the perimeter. This raft was cast in roughly 20m x 20m pours, with concrete delivered by wagons at a rate of one every two minutes. Temperatures were carefully monitored during curing of the raft.

Structural steelwork

The columns are generally 356mm x 406mm throughout, with plating added across the flanges in the lower storeys to give a constant inside flange line, simplifying the splices and the edge beam connection to the inner face of the external flange. This detail allowed for constant cladding-to-perimeter-beam and core-wall-face-to-perimeter-beam dimensions, thus maximizing the use of standard length secondary beams.

In the basement the columns become 800mm x 800mm fabricated box sections, carrying up to 48MN and weighing over 1 tonne/m length at the lower levels - a significant craneage issue.

Typical spans in the tower are 10.8m-12.8m, and the 1m floor sandwich gives a 200mm raised floor and 330mm clear services zone beneath the steel beam. Deflection limits for edge beams were tightened to reduce the costs of joints in the cladding.

The 75m square podium includes 16.5m clear spans, giving vast open spaces for the trading floors. A 22m span, full storey-height, transfer beam allows unrestricted lorry access in the basement loading bay.

'The challenge on this job was always going to be whether everyone could pull together to proactively solve problems on an extremely tight programme.

Arup and Cleveland Bridge worked closely together on the structural steelwork design to anticipate just about every potential construction issue, and the tower went up very smoothly.'

*Winston Huth Wallis,
Construction Manager,
Canary Wharf Contractors Ltd*

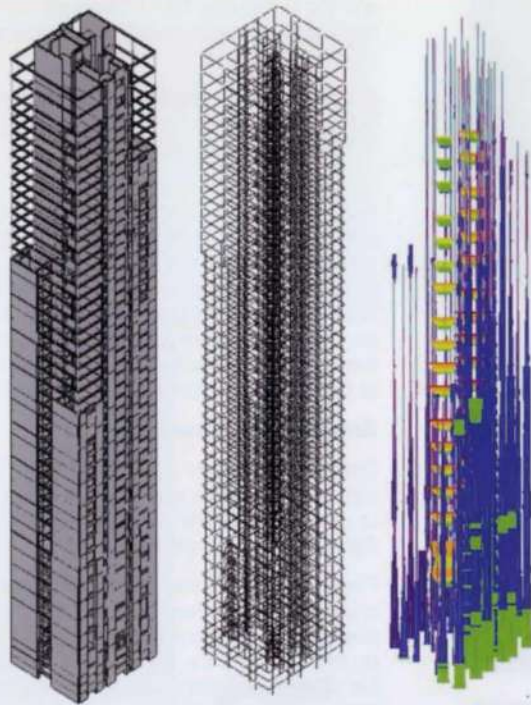

13. Skeletal 3D GSA model.

Maximum advantage was taken of the repetitious nature of a tall building to standardize framing and detailing of connections, Arup working closely with the contractor particularly on steelwork and concrete detailing.

For non-standard areas, such as the five-storey height entrance lobby where plate girders carry escalators up through the space, standard sections were developed to minimize material waste.

X-Steel was used at Cleveland's Darlington works as the drawing and fabrication tool. Document management was electronic throughout the project using Hummingbird, with electronic red-lining of drawings by the designers.

Core wall layout

The four banks of lifts form the core's primary cells, whose walls change thickness three times over the height - from 600mm to 450mm to 300mm.

The internal walls separating stairs, lift shafts, and risers are 200mm thick throughout the height, minimizing the space-take of the core and hence maximizing lettable floor space. An 8m wide central 'street', containing vending machines, meeting rooms, multifunctional print/scanning facilities, mailroom and storage area, separates the two 'halves' of the core, its walls structurally coupled across this divide in an arrangement that gives access into the street from at least one end on any one floor. Detailing of the reinforcement for the core walls was undertaken by Arup in house, with close collaboration with Byrne Brothers.

Structural analysis and core design

The core was analyzed using the skeletal 3D OASYS GSA model to predict the response of the building to vertical and lateral loads (Fig 13); static analysis to assess element forces due to gravity, wind, and notional lateral horizontal loads, and modal analysis to assess dynamic properties. The overall 3D model was supplemented with detailed finite element models (Fig 14), to confirm behaviour in areas of local discontinuity.

Wind loads induce lateral movements that need to be assessed against criteria which describe how far occupants perceive, and tolerate, tall building motions. Preliminary assessments of these lateral accelerations were made according to NBCC (National Building Code of Canada), and wind tunnel testing was subsequently performed on a rigid force balance model at the Boundary Layer Wind Tunnel Laboratory at the University of Western Ontario (BLWTL).

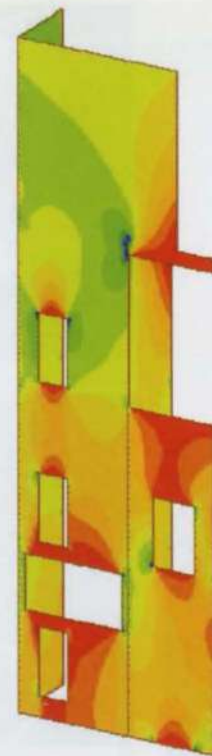

14. Detailed finite element model.

Load spectra from the wind tunnel testing were combined with modal properties extracted from the 3D analysis and processed by BLWTL to give predictions of pseudo-static peak wind forces on the building and accelerations experienced by the occupants.

The maximum predicted wind displacements were building height/2600 for overall displacement and storey height/2000 for inter-storey drift. These were well within the normal limits for tall buildings ($h/500$ and $h/300$ respectively), as the core size was determined by space planning rather than structural requirements.

Building services

Planning permission for the site had been based on the then standard Canary Wharf specification of an all-electric building with fan-assisted terminal variable air volume (FATVAV) air-conditioning.

Arup looked at several alternative systems for HSBC during the concept stages, including two and four pipe fancoils, gas-fired heating, and dockwater heat rejection. The Canary Wharf standard specification was adopted by HSBC, but several innovations new to Canary Wharf were brought into the building, with cost and space benefits.

The business-critical operations HSBC aimed to locate in its new HQ demanded robust building services to support and maintain them. During the design stage Arup carried out a detailed single point of failure (SPOF) analysis. This led to two separate and independent chilled water and heat rejection systems with their own pipe risers being provided, each rated for half the building's maximum load and each with N+1 plant capacity. Dual electrical power supplies come from independent London Electricity primary sub-stations, each rated for peak building load, and 10MW of in-house power is also provided by four duty and one standby generators to support life safety and essential loads including lighting, small power, and refrigeration/chilled water. Two large and complex UPS systems with battery backup ensure that should the London Electricity supply fail, business-critical operations are maintained at all times with no loss of power. An N+1 system serves the trading floors and the SERs on all the floors. A separate 2N system serves the CER, which handles HSBC's worldwide IT and data operations.

Duplications and triplications

Resilience in the cooling and electrical systems is a theme throughout the building. At the lowest basement level are two separate and fire-compartmented chiller plantrooms, whilst two pairs of 450mm diameter chilled water and two pairs of 450mm diameter condenser water (heat rejection) pipes rise through the building; two separate cooling tower heat rejection circuits are housed on the roof.

Two AHUs on each floor (each at 75% duty) provide chilled air to the FATVAV terminal boxes. Similarly, dual generator and UPS-backed busbars rise through the building to feed essential IT services throughout.

A triplicated generator control system was specified. Although well known in aviation, these do not usually feature in commercial buildings. The system triplicates all signalling between controlling devices using different cabling and routes, so if one system fails, the power remains operative on the remaining two. The generators have five days' supply of oil, with the storage tank located in the basement. An electrical network management system (ENMS) monitors the condition of the business-critical protective devices throughout the building. It monitors power quality including harmonics and records disruptions, minimizing future malfunctions by preventative maintenance.

The CER is provided with down-flow close control air-conditioning units. These have dual coils, each fed with chilled water from different chilled water systems, thereby ensuring that cooling is maintained at all times should one chilled water system fail. Having dual coils simplifies the controls and changeover valving arrangements, again enhancing the robustness of the system.

Acoustics

Nick Boulter

Arup Acoustics' initial appointment was to develop the acoustic design of the base building, beginning with a study to assess the levels of traffic and aircraft noise and the implications this had on the building envelope sound insulation requirements. Much of the early work concentrated on services noise control issues. The original concept centred around the use of acoustic AHUs, one per floor. These have greatly enhanced casing construction compared with conventional AHUs, resulting in very low plantroom noise levels and thus minimizing the sound insulation needs. This was shown to work well in a mock-up plantroom where noise levels were low enough to allow unattenuated return openings.

The appointment was extended to cover fitout acoustic design. This involved partition design and privacy issues, although services noise and room acoustic control were also key factors in many areas. The client wanted the flexibility for future 'churn', so floor-to-ceiling relocatable partitions were the intended norm, with higher performing slab-to-slab partitions only in a few critical areas.

For relocatable partitions to be useable, noise transfer via the common ceiling void needs to be controlled, and in areas with flexible partitions, the ceiling sound insulation was upgraded.

Initial sound insulation results were lower than anticipated. Significant improvements were made by modifying the partitions, but the resulting privacy was still inadequate, due to the unexpectedly low background sound from the services in some of the internal spaces. Levels in the affected rooms were therefore artificially raised by installing a low-cost sound masking system in the ceiling void. The sound generated was derived from recordings of real ventilation services, optimized to give the most appropriate sound masking spectrum. The resulting sound is natural for an office building and therefore unobtrusive to the users, and tests after the masking system was installed showed the target privacy standards to be achieved.

A combination of sound absorbing ceilings and absorbent wall linings built into the partitions controls the internal acoustics for the various partitioned spaces. The double-height boardroom, however, presented an interesting acoustic design challenge. To work effectively for video conferencing and recording, the space needed a well-controlled acoustic. The two end walls of the boardroom have fabric-faced acoustic lining, but the floor-to-ceiling glazing could not easily be made absorptive, and this made the wall opposite particularly critical. It is covered in a large world map made from extruded aluminium sections, with the oceans in inclined T-section extrusions perforated on the hidden surface and thus absorptive. Fortunately, our globe is mostly covered with ocean!

Economizing space

Space efficiency for the building services was also a prime concern. Numerous plant arrangements were tested to ensure that equipment was optimally located and future maintenance and replacement was also possible. Arup produced a plant replacement strategy report, which detailed the maintenance/replacement frequencies of the major components and the physical routes by which this could happen. Specialist contractors and the design team collaborated on the report, which was well received.

The layouts of the various engineering systems were also designed to maximize the net lettable floor space. Again with the architect and the client's agreement, the chiller plantroom room was designed without tube withdrawal space but with knockout wall panels instead to allow chillers to be removed for maintenance. The cooling water system was meticulously designed and tested as a single pressure zone (buildings of this height are normally divided into two or three), saving plant space normally needed for pressure break heat exchangers, secondary circulating pumps, and ancillary equipment and controls. To achieve this servicing strategy, the team analyzed the stresses in the piping system at the base of the building, and reviewed and checked in detail manufacturers' pressure ratings for coils. Having a single pressure zone ensured that chilled water at 6°C could be delivered to the entire building, ensuring that all cooling coils in the building are efficiently sized.

Another space-efficient design was the provision of a fresh air riser running through the building's concrete structure. Detailed analysis ensured that the structure's inherent thermal inertia did not adversely affect the treated fresh air thus supplied. The shaft was subsequently suitably finished to prevent mould growth and moisture migration into the structure. This fresh air shaft can also be used as for smoke extract in a fire.

Movement differentials

As a result of the single pressure zone design, Arup devised a way to allow for pipe thermal movement based on anchoring the two pairs of pipe risers at the base of the building on the structural raft, with expansion/contraction of the pipe risers taken up at the top of the building. This removed the need for a special structure to take up significant thrust forces normally required for anchors in a building.

As well as thermal expansion and contraction of the system, the design of all pipe risers had to accommodate differential movement of the structure as it shortens vertically after construction due to concrete creep and shrinkage. Special attention was given to how branch take-offs were made from the risers so that the horizontal pipework could take up the vertical movement of the branch. This was achieved by carefully implementing horizontal pipe loops to make use of the natural flexibility in pipework and bends to absorb the movement.

Water supply

The hydraulic static pressures arising from the building's height also impacted on the sprinkler system. Working closely with building control and the Fire Brigade, Arup negotiated a dispensation under the design codes to enable pressure reducing sets to be installed on the sprinkler systems.

Similarly, by working closely with the authorities Arup satisfied building control that with all the life safety systems of smoke extract, sprinklers, wet risers, fire and voice alarms, the hose reel installation could be omitted without prejudicing occupants' safety. The client was satisfied with this and recognized the added value that Arup had brought to the project.

Two incoming water supplies feed two potable water tanks. The potable water is purified using copper silver ionization; HSBC is believed to be the largest building in London to use such a system. Copper silver ionization is also used to treat the cooling tower pond water system in lieu of a normal chemical treatment system; this overcame any need for hazardous chemical storage and handling up to the top of the building.

Security

Simon Brimble

Arup Security Consulting was involved in designing the security installation from almost the inception of the project. The initial study was to develop a strategy for protecting the building fabric based on a threat and risk analysis. This work was later used to inform the blast commission that TPS Consult undertook through to project completion.

Following this involvement Arup was asked by HSBC's security department to provide security engineering services through the entire design period, onto site, and through to commissioning. This required a close working relationship with HSBC's security department and other members of the design team, mainly Foster and Partners, to produce an integrated approach to security. To enable this, Arup used a methodical approach, based on the client risk assessment and brief, to develop a detailed security plan that was tracked through the design process to provide an auditable trail. The security plan co-ordinated various parts of an integrated security strategy including operational procedures, physical and electronic security measures, and the planning and space requirements for security assets. One unusual but interesting aspect of the close collaboration with the client and other design team members was attending HSBC's monthly fire, safety and security working party meetings, where security was considered in the most holistic of ways.

The scheme comprised CCTV, access control, intruder detection, vehicle management, turnstiles, and control room systems.

The first security elements that most staff and visitors encounter are the pedestrian gates to control access. These were specially developed to maintain the visual objectives of the lobby design and provide an installation that would handle the total building population.

Through much discussion a sophisticated vehicle management control system was introduced to prevent vehicle tailgating.

The installation comprises 'vehicle airlocks' formed by impact-rated roadblockers, raising-arm barriers, and fast-acting speedgates. Throughout the development and implementation of the vehicle management scheme, Arup strove for a balance between the building security objectives and personnel safety, and the scheme was implemented for all vehicles including goods deliveries and private cars.

Close attention was given to integration with the building and its systems, including the use of the structured cabling system to transmit video signals, use of a common building LAN for IT, and access control through to custom-designed access controlled gate bodies, camera housings and brackets.

The successful realization of the security design was a co-ordinated effort between Arup, HSBC's security, facilities and project team, Foster and Partners, and not least the construction team of Bell Security and Canary Wharf Contractors.

Fire safety

Andrew Gardiner

Arup Fire was responsible for Category A and Category B fire strategies and also participated, as part of the design development process, in HSBC's monthly working group on fire, safety, security, and facilities management. This participation was a unique opportunity to explore how the complex operations required by modern banking integrate with design.

Questions arose from these meetings requiring a series of special studies.

Computer equipment rooms

One such study examined the fire protection needs of the very large main computer equipment rooms. They form an essential part of HSBC's business and there was much debate as to the degree of fire protection required. Arup Fire carried out a quantified risk analysis that superimposed a transient fire and smoke spread model onto a probability event tree. This allowed the consequences of success or failure of individual fire safety systems to be examined and put into context with the likely probability of these events occurring. The results were distilled down into a series of possible smoke, fire and water damage outcomes, each with a related return period.

This was then used to justify HSBC's choice of fire protection systems.

The History Wall

A more unusual study concerned the entrance lobby artwork. As part of the agreed fire strategy, the entrance lobby had to have a controlled quantity of combustible material which also had to exhibit very low surface spread of flame characteristics. Unfortunately, the artist's choice of material for the nearly 4000 perpendicularly-mounted flags in the History Wall was PVC, coated to accept a high quality photographic image.

Tests showed it to be easily combustible and with a very rapid surface spread of flame characteristic. Arup Fire and Arup Materials Consulting worked with the artist and HSBC to develop an acceptable solution.

The idea of a non-combustible aluminium substrate onto which the flags could be mounted was seen as a positive by the artist, and so a series of photographic plastics and papers were examined, not just for fire performance but also for UV stability, cleanability, and image quality. A series of fire tests eventually identified a product that satisfied all the criteria of HSBC, the artist, Arup, and the local authority.

Simultaneous evacuation

One final study, probably most important of all, arose from September 11, which occurred near the end of the shell and core construction phase. HSBC was keen to extend the standard phased evacuation procedures for fire and examine the most efficient way to evacuate the complete building simultaneously. Using a series of models, Arup explored with HSBC many different options and scenarios until one was chosen as the most practicable and efficient.

Key to the success of this was management of the evacuation and the role of the Building Emergency Co-ordinator. It was clear to HSBC that the person responsible should have a very high competency profile both technically and in decision-making during a stressful situation. HSBC's search for a person of the right qualities was successful and since occupation a series of full-scale evacuations have been carried out.

This has allowed systems to be fine-tuned to minimize evacuation times and also to better serve staff with mobility difficulties. In doing so, HSBC has set an example for others to follow.

15. The History Wall in the ground floor entrance lobby.

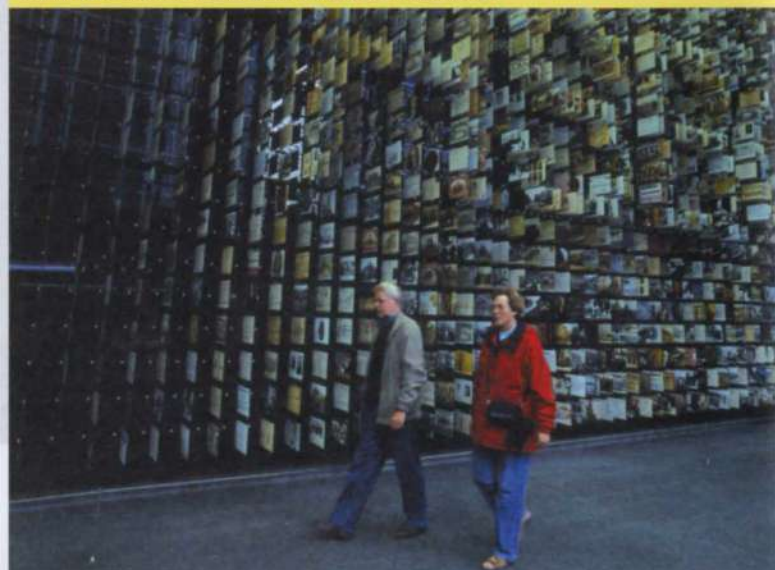

Building controls

HSBC is the first large-scale installation of Invensys Building Controls' new Sigma control system, specifically selected to complement the resilient mechanical and electrical design.

HSBC's BMS installation not only uses Arup standard controls design, but also implements a distributed starter approach. Instead of relatively few large centralized motor control centres supplied by a controls specialist, there are many individual starter enclosures provided by the associated mechanical equipment suppliers.

Each incorporates all hardwire interlocks required for the safe stand-alone operation of the plant, including all fire interfaces, allowing the drives to be commissioned before the controls were installed on site.

This effectively provided a plug-and-play approach for the equipment to be controlled. To complement this philosophy, Arup designed the controls using many small controllers distributed adjacent to each starter enclosure.

As the mechanical systems were generally designed with dual duty/duty plant configurations, it was necessary for the controls to mirror this by providing dedicated controllers for each item of plant. This modularity needed far more co-ordination between contractors than under a normal contract, with Arup successfully providing much of this co-ordination.

The FATVAV box and fan coil unit controllers are connected via an ECHOLON (Open protocol) data network, but communications between the main plant controllers utilize a proprietary dual redundant twisted pair network, linked to an ethernet backbone. Failure of the primary network causes an automatic changeover to the secondary standby network, creating a high-integrity, resilient data network. Similarly innovative dual flash allows firmware upgrades to the controllers to be carried out without the usual downtime ensuring continuous service while maintaining the most up-to-date software. The BMS system also interfaces with the lifts and escalators, lighting, and energy metering, to act as a gateway channeling and recording information to become the main portal for the building facilities management.

Providing for the client

For a building of its size, the design and construction of the new HSBC headquarters was efficient, cost-effective and innovative, while satisfying the client's desire to amalgamate all his 8000+ UK staff in a single building. HSBC wanted spaces to generate synergies among the staff, to reduce facilities management costs, to improve communications and to promote efficiency in central functions such as HR, Finance and IT. The design was key to improving business and providing an unrivalled working environment for the staff. Arup's design team met client requirements and the challenges of efficiency in relation to the scale of the building by applying appropriate and innovative design.

References

- (1) ZUNZ, J, FITZPATRICK, T, GLOVER, M, *et al.* The Hongkong Bank: The new headquarters. *The Arup Journal*, 20(4), special edition, Winter 1985.
- (2) MUDD, I and WILLIAMS, G. Canary Wharf. *The Arup Journal*, 27(2), pp10-14, Summer 1992.
- (3) CHAPMAN T J P, *et al.* 'Advances in understanding of base grouted pile performance in very dense sand'. International symposium on tunnel construction and piling. London, pp57-69, 1999.

Credits

Clients:
HSBC Holdings plc
Canary Wharf Contractors Ltd

Architect:
Foster and Partners

Project manager:
HSBC/Canary Wharf Ltd

Structural, MEP, fire, acoustics, security and building controls engineer:

Arup Mark Adams, Graham Aldwinckle, Joanna Allen, Malcolm Ashmore, Trevor Baker, Phil Barker, Richard Bartlett, Peter Berryman, Nick Boulter, James Bown, Derek Brewster, Simon Brimble, Stas Brzeski, Matthew Bumpass, Tim Casey, Tim Chapman, Dave Choy, Andrew Christie, Iain Clarke, Nigel Cliff, Judy Coleman, Darren Connolly, John Coppin, Richard Coveney, Richard Cowell, Paul Cross, Daniela Daffara, Menino Da Silva, Ismena Deacon, Peter Deane, Asha Devi, Enzo Di Lenno, David Dollman, Thomas Dossenberger, David Easter, Karen Elson, Mike Evans, David Fearon, Tony Fitzpatrick, Alan Foster, Suzanne Freed, Andrew Gardiner, Anne Gilpin, Andrea Gnudi, Jeff Green, David Gubb, Stuart Hall, Simon Ham, Andrew Harland, Steve Harris, Mike Hastings, Geoff Higgins, Ernie Hills, Peter Ho, Karen Holt, Bill Horn, Nick Howard, Rachel Hughes, Daniel Iffland, Adam Jaworski, Richard Jelbert, Ivan Jelic, Barney Jordan, Tarsem Kainth,

Beihan Keenan, Edward Lam, Ben Lawlor, Stephen Lees, Gerry Loader, Kate Longley, Paul Malpas, Jim McCarthy, Gordon McDonald, Sean McGinn, Steve McKechnie, Tony Minchinton, Steve Mitchell, Yoshiyuki Mori, Paul Morrison, Wolfgang Muller, Karen Naughton, Sohail Nazir, Duncan Nicholson, Tony Noad, Sarah O'Driscoll, Julian Olley, Andrew Painter, John Papworth, Lucy Patenall, Val Pavlovic, Garry Porter, Daryl Prasad, Henry Quek, Stuart Redgard, Simon Reynolds, Gregg Richardson, Edward Robinson, Toby Robinson, Mark Rowan, Mark Ruohonen, Eddie Scuffell, Geoff Shoter, Clem Smoothy, Les Stokes, Arra Tan, Alan Todd, John Veale, Bob Venning, Faith Wainwright, Karen Warner, John White, Adam Wildon, Jim Williams, Ben Williamson, Shaun Woodhouse, Louise Wright

Lift consultant:
Lerch Bates & Associates

Quantity surveyor:
Davis Langdon Everest

Audiovisual consultant:
CMS

Catering consultant:
GWP

IT consultant:
PTS

Management contractor:
Canary Wharf Contractors Ltd

Steel frame contractor:
Cleveland Bridge

Concrete frame contractor:
Byrne Brothers

Mechanical contractor (base build):
Crown House

Mechanical contractor (Base build/fitout):
Hotchkiss

Mechanical contractor (fitout):
Rosser & Russell

Electrical contractor (base build):
T Clarke

Electrical contractors (fitout):
PIP
RTT

Fire alarms supplier/contractor (Base build/fitout):
Siemen's (Cerberus)

Security supplier/contractor (base build/fitout):
Bell

BMS/controls supplier/contractor (base build/fitout):
Satchwell

Lifts supplier/contractor:
Fujitec

Illustrations

- 1: Peter Mackinven/VIEW
- 2: Denis Kirtley
- 3: Daniel Blackhall
- 4, 6, 8, 11, 15: Central
- 5, 7, 9, 16: Dave Choy
- 10, 13, 14: Arup
- 12: Steven Jenkins



16. Symbolic HSBC Lion brought to the new headquarters from the Hong Kong building.

'The very demanding fast track programme was only achievable because of the first rate personnel from the designers, contractors and clients who were highly committed to the project and maintained the confidence of the Bank throughout. HSBC are delighted with the completed building.'

Mike Smith, Project Manager, HSBC

Pfizer OSP4, Ringaskiddy, Ireland

Sean Clarke Andrew Nixon Hugh O'Dwyer



1. The finished goods building with the production building in the background.

Background

Back in the 1960s the Irish government identified Ringaskiddy in County Cork, Ireland, as a potential centre for fine chemical and pharmaceutical manufacturing. At the time, and allied to the government's decision, Pfizer was establishing a citric acid plant in the area. Utilities in the general locality were still underdeveloped, which necessitated, for instance, Pfizer drilling a series of wells to augment the public water supply.

The fledgling Industrial Development Authority purchased in excess of 400ha in Ringaskiddy and spearheaded a visionary plan for its development. The land was quickly zoned industrial by Cork County Council. Power and water supplies were substantially reinforced, ready for new industry. A natural gas supply to the area was installed in the early 1980s.

Pfizer added a significant organic synthesis manufacturing capability (OSP1) to its operating citric plant in the early 1970s, and a second unit (OSP2) in 1982. These plants manufacture bulk active ingredients for various drugs. In the early 1990s, Pfizer sold its global citric acid business, including the Ringaskiddy facility, to Archer Daniels Midland (ADM), who continue to operate on the site to this day.

Meanwhile, other pharmaceutical/fine chemical plants were moving in, like Angus Isochem (later to become Hickson, then Warner Lambert, and now Pfizer Loughbeg), Penn Chemicals (subsequently SmithKline Beecham and now Glaxo SmithKline) and, in the late 1980s, Sandoz (now Novartis).

Little Island, on the other side of Cork Harbour, was also developing as a pharmaceutical manufacturing centre for Henkel (now operated by Cognis), Gaeleo (later to become Pharmacia and Upjohn, and now Pfizer Inchera), Janssen (a Johnson & Johnson subsidiary), Cara Partners, and Plaistow (now Pfizer Little Island). Cork was now a pharmaceutical manufacturing cluster of worldwide importance.

In 1991 Arup's Cork office began front-end design with process engineers Badger Catalytic (later United Engineers) on Pfizer's 7000m² OSP3 in Ringaskiddy. Arup in Cork had already developed substantial expertise in the design and construction management of pharmaceutical manufacturing buildings and associated offices, laboratories and infrastructure, particularly with the firm's work on the large greenfield pharmaceutical development for Sandoz on a nearby site¹. These skills were consolidated and developed on OSP3, which went into production in 1994.

By 1998, Pfizer was ready to expand further its capability at Ringaskiddy and asked Arup to explore options for locating its fourth organic synthesis manufacturing plant on the existing site. OSP4 is a multi-purpose manufacturing plant making bulk active ingredients for various Pfizer drugs. Arup was then appointed by Pfizer to provide civil, structural, geotechnical, architectural, environmental, fire, building services, and cost engineering design for the 250M Euro project. Foster Wheeler/PM was appointed as process engineer and design team leader.

Sustainability, the environment, and safety

OSP4 is designed to produce high-quality pharmaceutical materials in a clean, safe environment. Building finishes, air handling, and environmental controls all contribute to this. All the external piperacks have concrete aprons to contain spills. Weak effluent systems in each building are designed to take firewater flows to avoid overspill into safe areas. Hard-paved areas are provided around each building to prevent fire flows potentially getting to soft-landscaped areas. Underground weak effluent systems are double-contained, again to protect the groundwater. Stormwater is routed through Pfizer's retention pond system and can be captured in the event of any contaminant detection. Solvents are recovered for re-use where possible, and air emissions are controlled and cleaned before discharge to atmosphere.



2 left. Aerial view of Pfizer's Ringaskiddy site, with OSP4 in the foreground. The hydrogenation building is not yet constructed in this photograph.

3 below. Finished goods building (left); production building (centre); solvent recovery and end-of-line devices (right).

The OSP4 plant

The key elements of OSP4 are:

- five-storey, 33m high, 10 000m² production building housing production areas, control rooms, electrical rooms, general plant areas, office suites on two floors with views over Cork Harbour, and a substantial in-process laboratory with high-containment areas
- finished goods building comprising a 13m high air-conditioned warehouse with cold store and shipping area, a five-storey milling and dispensing facility, a 500m² QA/QC laboratory with high containment areas, a canteen and miscellaneous locker rooms, support, and plant area
- hydrogenation building (pp24-25)
- external open steel structures, extending typically to the height of OSP4, containing solvent recovery batch stills, scrubbers and other equipment to support process activities
- solvent tank farm
- extensive infrastructure including roads, piperacks, foul, storm and weak effluent drainage, water mains, and service ducting.

Locating OSP4

The team looked at several onsite and offsite options for OSP4, and prepared broad comparison cost estimates. Offsite locations were ruled out after some consideration. Onsite, OSP4 could be located either near the existing production grouping or away from the existing production areas as a stand-alone satellite campus with a 'green belt' between it and the main plant.

Arup carefully studied both alternatives, and tested the conclusions in workshops with a project steering group that included Pfizer corporate and production personnel. Discussions focused on topographical and geotechnical issues, potential cost savings from sharing production support activities like solvent storage and recovery, stormwater retention and waste treatment, and traffic and pedestrian circulation. A key preference emerged to make the new facility a stand-alone entity with umbilical connections to the main plant. The topography and geotechnics would be more challenging, but manageable within the scale of the proposed development.

Masterplans were prepared for the separate campus and the project marched on to front-end design. Process engineers Foster Wheeler/PM, joined the team, and Arup appointed RKD McCarthy Lynch as architect and Bruce Shaw as cost engineering sub-consultants.

Stormwater would be contained, including potentially large fire flows, and routed by gravity through Pfizer's retention pond system for the existing plant.



A similar pumped connection to the existing waste treatment plant was also feasible. A new entrance to the N28 main road was agreed with Cork County Council and the National Roads Authority. A road link to the main plant was also addressed. Routing studies for a major piperack bringing solvent pipes, water, power and datacoms were organized. This piperack ultimately had seven tiers, 4m wide, for all the piping and services at a clear height in excess of 6m to allow large truckloads, eg new vessels, to pass beneath.

Front-end design

Important Arup-designed activities included:

- masterplanning the site as a whole
- assessing use of the sloping topography, particularly relating to linkages between buildings
- geotechnical investigation
- preparing planning permission documents, including an Environmental Impact Statement
- preparing fire safety documents to obtain a Fire Safety Certificate
- building layout studies
- preliminary structural scheming
- underground and ground level infrastructure design
- entrance roads and car parking design
- +/-10% estimating
- time schedule for detailed design and construction

In all this Arup worked in close co-operation with Pfizer's project personnel and the Foster Wheeler/PM team.

Pfizer asked Arup to explore options for locating its fourth organic synthesis manufacturing plant on the existing site. The commission was extended to provide civil, structural, geotechnical, architectural, environmental, fire, building services, and cost engineering design for the project.

Structural systems

For sustainability reasons, Arup endeavoured to maximize the use of concrete in the buildings as it is an indigenous material with a lower embedded energy than steel. OSP4's production building is founded on limestone, and conventional pad and strip foundations were used. The superstructure is a hybrid system of structural steelwork with reinforced concrete columns and main inverted T-beams spanning 7.5m (Fig 4). All secondary beams are in steel and typically span 7.5m onto the ribs of the T-beams (Fig 5). Through-deck shear studs were welded on site to the tops of the beams to act compositely with the concrete slab. Arup had used this design on OSP3, and found it to be very flexible in that the steel beams could be relocated along the inverted T-beam nibs until the last minute before pouring the concrete floor slabs. Also, the steel beams can be very accurately positioned (to steelwork tolerances) - not easily achieved with concrete. Such accuracy is essential for many of the floor beams, which also act as vessel support beams.

The secondary steel beams support a composite metal deck with dovetail slots suitable for suspending services below. The floor slab poured on the metal deck is a composite slab to falls and cross-falls.

The warehouse in the finished goods building is founded on fill. A raft foundation supports the precast concrete portal frame superstructure with a precast beam and column structure to one side. Precast concrete was selected because this area had to be built very quickly to act as a construction warehouse, and because the insurers required a four-hour fire rating on the structure given the value of the stored product (including Viagra). The milling and dispensing part of the finished goods building is in conventional beam and slab reinforced concrete.

This part of the building also contains a basement cut into limestone with a tunnel link to the production building. As well as this tunnel link, an 18m long enclosed steel bridge, curved on plan connects the buildings at high level. The bridge also acts as a piperack. Arup's OASYS software was extensively used in the structural design.

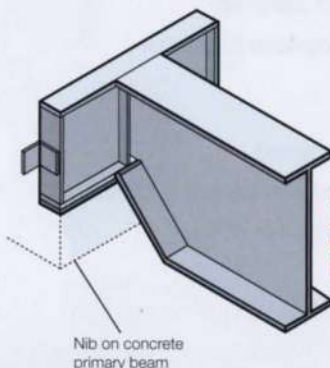
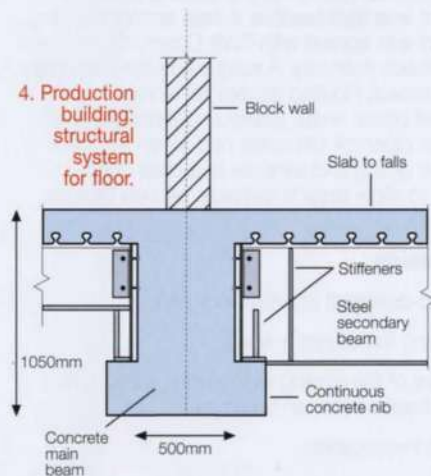

5. Production building: steel end connection on nib of concrete primary beam.

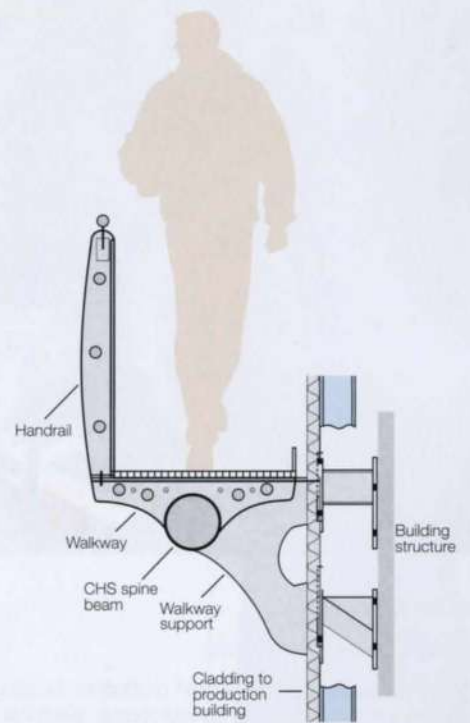

6. Production building: typical section through external walkway.

Each floor of the production areas contains substantial and geometrically complex stainless steel platforms for access to vessels, reactors, and other items of equipment. On previous projects these structures were seen to have a significant effect on the overall aesthetic, so each was designed from first principles with very careful detailing. The positive impact can be readily observed on a walk-through of the plant. Designs for secondary structural elements like balustrading, balconies, and escape walkways were developed to match the quality of the integrated cladding and glazing systems (Fig 6).

Deflagration venting

A deflagration is the subsonic propagation of a combustion zone. Buildings containing fuel in the form of flammable gas, mist or combustible dust, plus an oxidant concentration sufficient to support combustion in the presence of an ignition source can be susceptible to a deflagration.

Pfizer required the production areas in OSP4 be designed to cater for deflagration in accordance with the spirit of NFPA68². The finished goods building did not need deflagration protection as solvents are not used there. Deflagration vents located on the full production building perimeter, are designed to release at a low internal pressure of 2kN/m², just above the worst wind load case for the building.

Releasing these vents would relieve internal pressure from a deflagration and so reduce the potential for structural damage. The deflagration vents comprise the external steel cladding itself - 60mm thick Kingspan composite panels fastened to support steelwork with colour-coded explosion venting fasteners. These are manufactured with aluminium washers that collapse at a specified load allowing the panels to release from the building elevation.

Custom-made stainless steel restraints developed jointly by Arup and SIAC Construction (a local cladding and roofing contractor), incorporating tethers and shock absorbers, tie one end of the cladding panels to the structure, preventing them from becoming projectiles (Fig 10, p24). The restraint system was fully tested to confirm its adequacy.

Pressure-resistant elements, such as the main structural frame, floors, and reinforced concrete walls separating the production areas from the non-production 'people' areas and escape stairs, are designed to withstand a deflagration with an equivalent static load of 10kN/m² typically.

The primary aim is to contain a deflagration event to the production part of the floor affected. Some production areas are subdivided, for good manufacturing practice containment reasons, by walls typically constructed of hollow blockwork and jumbo stud partitions, designed to fail at pressures of about 3kN/m². The horizontal bed joints of the blockwork walls were reinforced with proprietary stainless steel wires in every horizontal course to help keep the masonry panels intact as they fall over in a deflagration.

3-D digital model

Meticulous interdisciplinary co-ordination is required in the design of any pharmaceutical plant.

For OSP4 this was even more critical, as the design was carried out at four different locations - Arup in Cork, Foster Wheeler in Reading, England, Project Management in Cork, and the construction management (CM) team on site at Ringaskiddy.

3-D microstation PDS models were created by each discipline for all areas where significant co-ordination was required, including the production building and most external areas. The specific packages used by Arup Cork included Speedicon and Frameworks. These models were sent regularly (at least once a week) to Foster Wheeler for incorporation in the overall model. Once loaded in Foster Wheeler's overall model, a clash detection package could be run. An Arup co-ordinator at Foster Wheeler reviewed the clashes, agreed solutions, and arranged for Arup to adjust the model to eliminate these clashes. With clashes eliminated from the overall model, construction drawings could be extracted from it.

The steelwork contractor, Cronin and Buckley, was able to accept the Frameworks model from Arup, which was then converted to X-Steel for use directly in preparing fabrication drawings. This minimized site clashes between disciplines, sped production of fabrication drawings, and improved drawing accuracy.

'Walk through' reviews were facilitated throughout the design between the team and Pfizer, ironing out many potential construction and operational issues.

Building services design

Arup's design scope included the full services design for laboratories, warehouse, offices, canteen, and miscellaneous people areas, plus co-ordination of all services in the milling and dispensing parts of the finished goods building. Foster Wheeler/PM designed the process elements including all the equipment, piping, and HVAC in the production areas, together with the electrical and instrumentation design.

Some interesting features within the building services design and construction management included:

- daylight-simulating artificial lighting within the 24-hour continuously operated control centre (Figs 7 & 8) so as to synchronize with the circadian rhythms of the control room staff. An Italian system custom-designed for the application was used.
- 3-D modelling of all services within the laboratories and offices in the OSP4 building, which integrated with the overall process and structural digital model of the building
- modular approach to the link bridge construction, which required full off-site fabrication
- commissioning of medium voltage electrical switchgear including resolution of a complex vibration issue in the standby generator
- lead role in the design and construction management of the laboratory benching, fume hoods, and work-up areas
- extensive laboratory gas and water utilities including hazardous gases like hydrogen and acetylene.

Arup's HVAC concept for the laboratories enabled a high containment performance for the fume hoods and the provision of adequate pressure cascades for the clean rooms. The laboratory spaces typically need very high air circulation rates to ensure total fume entrapment within the fume hood sashes.

The ventilation systems for the milling and dispensing areas were designed for product containment using extensive pressurization regimes and HEPA filtration.

The main text continues on page 26 ►



7 left and 8 above. Artificial lighting in the production building control room at different times during the 24-hour cycle. It is manned around the clock, and so the lighting system has been designed to synchronize with the circadian rhythms of the staff.

The hydrogenation building

General

OSP4's hydrogenation suite was constructed after the completion of the OSP4 main project. It comprises two independent cells housed in a three-sided concrete enclosure with pressure relief panels on the fourth side and the roof. Because hydrogen is explosive, the concrete walls have to withstand explosion loadings while the relief panels allow dissipation of the blast pressure. The building height is approximately 17m.

The team set out to deliver a top-quality exposed concrete building, which would function well within a pleasing work environment while respecting its natural and man-made surroundings. Arup introduced several innovative solutions to the detailed problems set by the brief for this unusual building, as follows:

Location

Early on, Arup reviewed three locations for the hydrogenation building, a key influence in the choice for which was the site topography.

The main materials access to a hydrogenation building is required at first floor rather than ground floor level; the sloping site chosen facilitated direct access from the higher level at the rear of the building.

New standard in quality

Pfizer is accustomed to purely functional hydrogenation buildings at its Ringaskiddy site. The OSP4 complex designed by Arup sets new standards for aesthetics and functionality at Ringaskiddy, and the OSP4 hydrogenation building needed at least to match the quality and aesthetics of OSP4 as a whole. The attention to detail and simplicity of form on this industrial building are truly innovative in that a very high quality is achieved without Pfizer paying a cost premium.

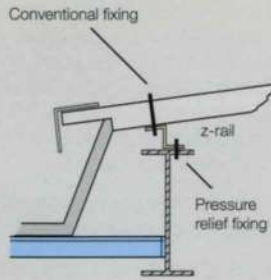

9. Detail of z-rail connection on roof of the hydrogenation building.

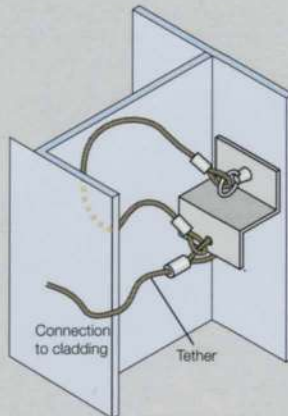

10. Tethered panel restraining system.

Blast-resisting walls

This building is designed to withstand blast from within. It is also designed to direct blast waves externally in a predetermined and safe direction via one of its walls, constructed in lightweight *Kalwall* material. The other three walls are in reinforced concrete, 500mm thick and designed to resist blast loading, shrapnel damage, and dynamic loading from exploding reactor parts.

These substantial walls are exposed externally, rather than covering them with steel cladding as on other previous Pfizer Ringaskiddy hydrogenation buildings, thereby achieving important savings. A pattern of rebates was introduced to break up the visual mass of the large concrete areas; construction joints typically coincide with the rebates. The patterning provides an echo to the *Kalwall* panel framing.

Blast-relieving wall

Kalwall is a structural composite sandwich panel formed from translucent glass fibre faces bonded to an extruded aluminium frame. It is designed to release from the building following an increase of internal pressure above 2 kN/m^2 , thus minimizing blast impact on the blast-resisting walls. Arup selected *Kalwall* because it is very light, and thus will cause minimal damage within the blast zone. The *Kalwall* wall is north facing, and the translucent panels provide a beautiful crisp natural lighting level in the building, which saves on artificial lighting. The aluminium framing within the panels can be discerned through the fibreglass, giving an almost 'Japanese tea-house' effect.

Blast-relieving roof

In addition to the blast-relieving *Kalwall* elevation, the roof – constructed like the deflagration venting cladding on the production building – is similarly designed for release from the building. Pressure-relief fixings are equipped with washers that collapse under a specific internal pressure, allowing the panels to slip past the fixing and release from the building. Pressure-release fixings on roofs are prone to leaking, so Arup, in conjunction with the contractor, devised a z-rail system (Fig 9) to sit on the steel roof beams.

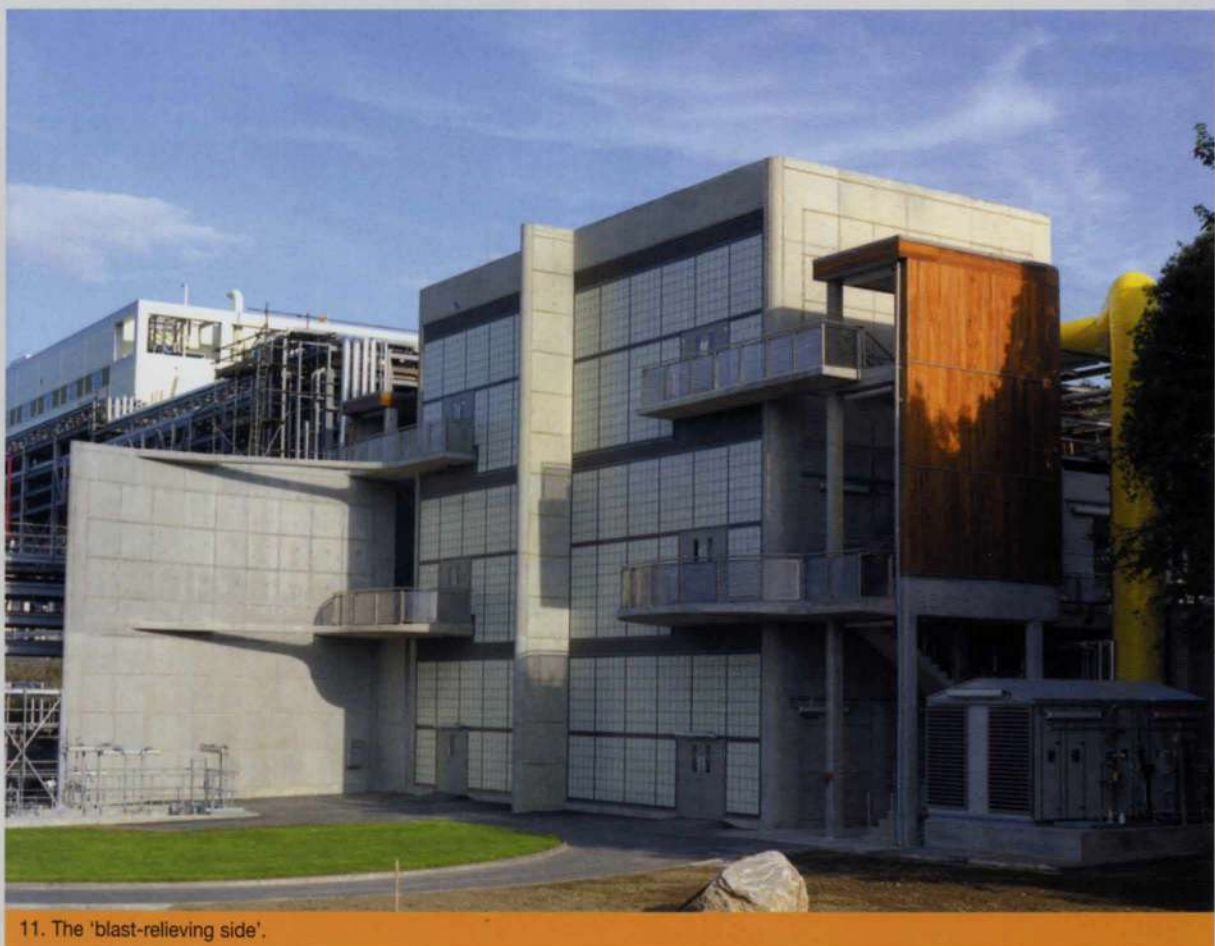

11. The 'blast-relieving side'.

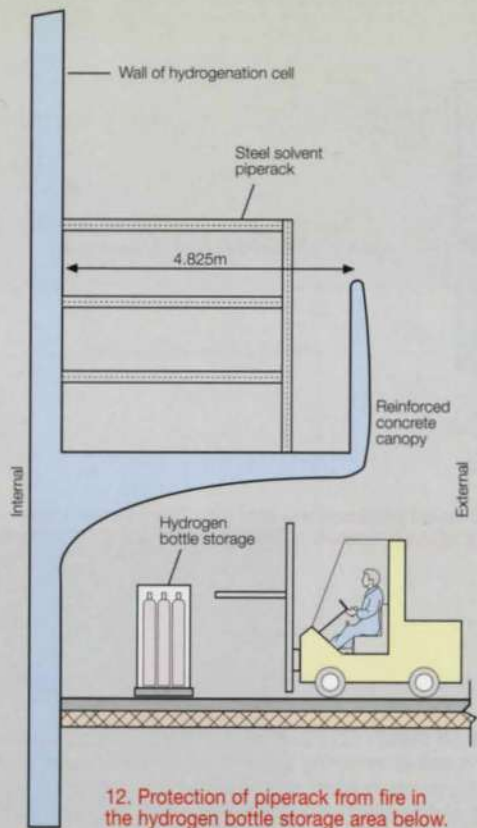

12. Protection of piperack from fire in the hydrogen bottle storage area below.

Conventional fixings were used between the roof cladding and the z-rail, and the pressure-relief fixings between the z-rail and the beams. This overcame the potential for roof leaks at the pressure-relief fixings as they were now all internal. The roofing panels are tethered to the structure with stainless steel wire ropes so that they can release pressure but remain attached.

Landscaping

The site for the hydrogenation building was originally a wooded bank containing an impressive evergreen Holm Oak with a natural pond in front of it. The innovative architectural layout for the building developed by Arup focused on maintaining and complementing this tree. Red Cedar cladding was selected for the external escape stairs to soften the building's appearance and to blend in with the existing sylvan environment.

Safety aspects of the layout

The building layout incorporates access to the building primarily from the rear, protected by the thick blast-resisting walls. The escape stairs are also strategically placed away from the hydrogenation cells, behind the line of the blast-relieving elevation and protected by the blast-resisting walls. These features increase safety for the building's operating staff.

HVAC piperack

For aesthetic reasons, a large external circular duct was clad in bright yellow to contrast with the grey concrete. To support and give expression to this duct, a minimalist piperack consisting of curved circular hollow sections with ductwork fin supports was incorporated.

Cantilevers

Pfizer required the blast-relieving elevation to be as clutter-free as possible. Typically, hydrogenation buildings have external steel walkways supported by steel columns to their fronts, but here external balanced curved reinforced concrete cantilevers, with sloped soffits, have been designed to allow access to the building. These cantilevers project 2.8m and can support forklift loads of 15kN/m². They fulfil Pfizer's desire for absence of clutter, and add significantly to the building's appearance.

Canopy

On the rear reinforced concrete wall, Arup proposed and designed a reinforced concrete slab with a curved soffit and a curved 21m long parapet beam to provide fire separation between an external hydrogen bottle bank and a solvent piperack at a higher level. The curved soffit slab is designed to allow an unencumbered path for escaped hydrogen upwards and outwards away from the overhead piperack (Fig 12).

13. Propped blast protection wall.

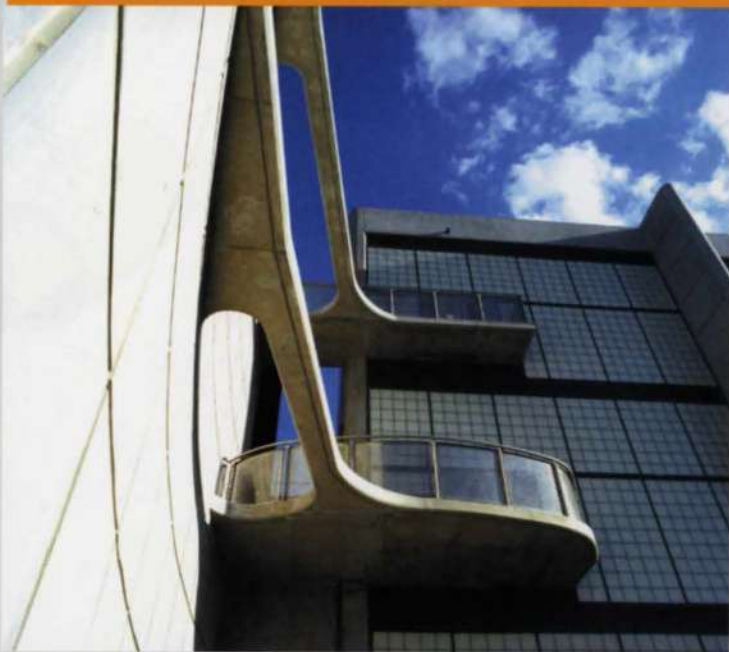

14. Escape walkway.

Weak effluent sewer

Pfizer required a double contained stainless steel weak effluent process sewer to serve the hydrogenation building. Arup proposed a more economical polypropylene outer pipe and stainless steel inner pipe solution, which was accepted (Figs 15 & 16). This was the first time that this sewer system was used on the Pfizer Ringaskiddy site and resulted in savings on drainage cost of about 20%.

Floor finishes

The Arup team put much effort into researching and specifying high quality acid-resistant tiling, epoxy and polyurethane floor finishes for the project.

Each proposed system was assessed for chemical, slip, impact, temperature, and mechanical resistance, conductivity/anti-static properties, aesthetics, and hygiene. All production floors are electrostatically conductive and have an average resistance not greater than 1×10^6 ohms when tested to BS2050.

In the production building, two epoxy products by MC-Building Chemicals Ltd were used extensively. The first, and predominant, was *MC Décor*, an aesthetically pleasing, medium/high chemically resistant floor finish with good impact resistance and anti-static properties. For floors needing higher chemical resistance, *MC Dur 1800AS* was specified.

For hardwearing areas requiring high impact resistance, acid-resistant floor tiling was used with a furane mortar. This mortar is a difficult material and needs to be laid in carefully controlled conditions.

For the finished goods building milling and dispensing areas, a polyurethane terrazzo system by Resdev was selected.

The 'people' areas have more familiar carpet, vinyl and pre-tiled raised floors, but anti-static issues were again important in the control room areas.

Overall, aesthetic quality was significantly enhanced by meticulous attention to detail in both the design and construction. Particular care was taken with covings, base plates, joints, floor gullies, and earthing strips.

External structures

An array of external production support facilities were needed, many of them - primarily north and west of OSP4 - requiring external open steel structures.

These include solvent recovery, mother liquor, scrubbers, thermal oxidiser, tanker unloading, the solvent tank farm, bulk storage, utility storage, the vertical pipe access tower, and all their interconnecting piperacks.

All the steelwork is galvanized.

The six-storey solvent recovery structure - 18.4m long, 8.5m wide, and 30m high - supports towers, condensers, main pots, main pot heaters, decanters, and reflux pots. Due to the sensitivity of some of this equipment, the structural lateral deflection was limited.

Some small external buildings were also constructed, including the PSA building, the MCC/Deluge building and the Syltherm pump building - the latter of particular interest as it had specific acoustic requirements with which Arup Acoustics assisted. Other external structures include bunded areas, cooling tower bases, weak effluent sump, generator base, and about 310m of reinforced concrete retaining walls.

Contractor procurement: 'preferred contractor' approach

Initial discussions were held jointly between Pfizer, the process engineer and Arup to agree the most beneficial contractor procurement method and the format of the CM set-up. The scale of the project was such that even the biggest Irish contractors would be challenged to cope with the anticipated workload. In addition, the work would be carried out within the very active Irish economy, with construction growing extremely rapidly.

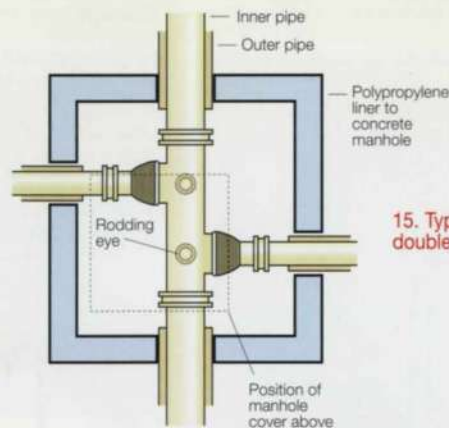

15. Typical weak effluent manhole, showing double contained polypropylene sewer.



16. Double contained polypropylene pipework. The pipe sizes vary but the annular space is typically about 20mm.

The
state-of-the-art
OSP4
is regarded as
the model for
multi-product
API
(active
pharmaceutical
ingredient)
plants in the
industry.

The full range of procurement methods, from traditional competitive tendering to alliance contracting, was reviewed and a decision taken in June 1998 to proceed with the civil and building works procurement on the basis of a 'preferred contractor' approach.

As part of this selection procedure four of Cork's main building contractors were requested to prepare detailed submissions on their approach, together with their capability. Each was asked for a priced bill of approximate quantities for the entire civil, structural, and architectural work scope, thereby establishing key rates and the level of site set-up and preliminaries costs. Interestingly, variation in weighted rates was less than 5% across the four. Interviews then reviewed each contractor's approach in terms of management, project execution, safety, current workload, commercial agreement, and track record on pharmaceutical type projects. A scoring system was developed to assist in selecting the successful contractor with cost comparisons also forming a key element.

The advantages of the preferred contractor approach included:

- Early contractor appointment allowed key construction personnel to get involved in constructability and schedule reviews whilst feedback could still be incorporated in the design.
- The best contracting team could be selected based on previous experience in this type of construction, proposed work approach, and projected costs. This significantly helps to ensure construction of a quality project at an acceptable final cost.
- Teamwork between designers, CM team and contractors is strengthened.
- Labour availability and procurement of specialist trades can be addressed at an early stage.
- Significant elements can be handled as sub-contracts let by competitive tender with the main contractor operating an 'open book' policy. This was to become key, as the considerable overlap between design and construction required specialist sub-contract packages to be bid and awarded in line with available engineering designs. The preferred contractor approach enabled construction to start with only 25% of the design complete.

After review, it was agreed that the civil and building works would be subdivided between the two top-ranking contractors. The production building, external works and underground services were awarded to John Sisk and Son, and the finished goods building to Bowen Construction.

This scope split enabled each to focus in detail on project execution and critical schedule milestones in their individual area. Contract award was based on the Institution of Engineers of Ireland Conditions of Contract, modified as necessary to incorporate specific Pfizer requirements.

The decision to split the civil and building work between two contractors proved to be a key advantage by ensuring strong management and adequate construction resources were available in each project area.

Construction management (CM)

The CM team was located in a 200-year-old stables, on Pfizer property, adjoining the construction site. These buildings had been renovated as part of the initial site set-up and enabling works. As with previous Pfizer Ringaskiddy projects, the CM team was led by key Pfizer personnel with specialist staff from Arup and Foster Wheeler/PM.

The CM personnel from each company were fully integrated within the Pfizer-led set-up, the complete team comprising around 40 people at peak. They were organized on two levels; one carrying out contract management and support functions like cost and schedule control, contract administration, industrial relations, and documentation control, the other directly supervising on site, including verification of day-to-day site quality.

A separate field engineering group was established on site to link design with the CM activity, comprising key designers whose role was to complete any remaining design activities and respond speedily to design-related queries and problems at site.

OSP4 took place against the backdrop of increased industry awareness of and focus on safety, so this aspect was top of Pfizer's priorities from the outset and throughout, with continued emphasis on developing safer systems of work and safety awareness.

As engineering design packages became available bid documents were prepared in the engineering offices and packages let by the CM team, who handled ongoing contract administration, including regular contract and commercial meetings through to settlement of final accounts. The cost control systems established on site tracked weekly any variations in expended or committed costs, and monitored variations and closeout required approvals. These monitoring tools were part of the whole project's integrated cost book, which had a common overall structure for each of the 27 main contracts. Each contractor was requested to tailor their cost reporting systems to conform to the CM / Pfizer system.

17. Project time schedule.

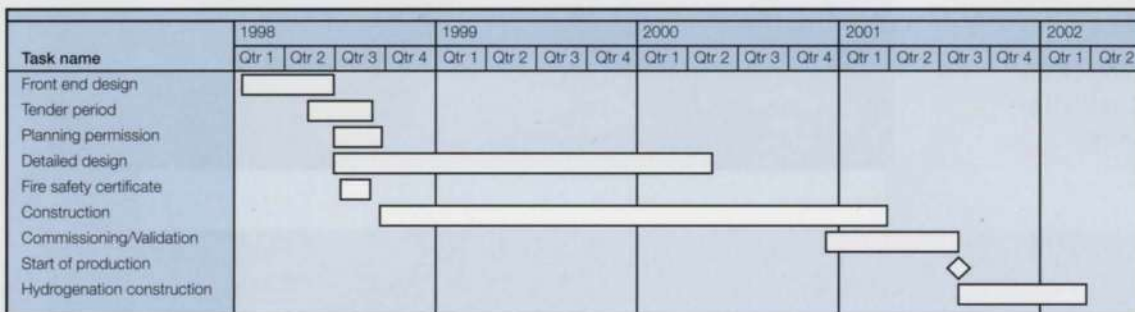

A field co-ordinator handled the day-to-day management of on-site issues with field supervisors from each discipline tasked with the ongoing resolution of co-ordination issues. In the latter stages of the project area supervisors were appointed with overall multi-disciplinary responsibility for handover of designated areas and systems to the Pfizer-led commissioning team.

18. left: Reactors in the production building.

19. right: Interior of laboratory.



Conclusion

The project began production in 2001 after a huge design and construction effort involving peaks of manpower on site of just under 1000 people and about 180 on the design side. The interdisciplinary co-ordination proved to be the key factor in delivering the project on time and within budget. The state-of-the-art OSP4 is regarded as the model for multi-product API (active pharmaceutical ingredient) plants in the industry.

References

(1) MEHIGAN, Jerry. Sandoz Ringaskiddy Ltd, Cork. *The Arup Journal*, 30(3), pp3-7, 3/1995.

(2) NATIONAL FIRE PROTECTION ASSOCIATION. NFPA68. Guide for venting of deflagrations, NFPA, 1998.

Project statistics

- 27 main contracts on site
- 214 000 litres of reactor capacity
- 80km of piping
- 3600 instruments
- 530 000 design hours
- 316 000 construction management hours
- 1 900 000 construction hours

20. Jacket pump room in the production building.



Award

Irish
Construction
Industry
Federation:
Best Industrial
Building in
Ireland Award,
2001

Credits

Client and construction manager:
Pfizer Ireland
Pharmaceuticals

Process engineer:
Foster Wheeler/PM

Building and civil engineer:
Arup Consulting Engineers
Pat Aherne, Tony Aherne,
Tony Ambrose,
Anna-Maria Barry, John Barry,
Nick Boulter, John Boyle,
John Burgess, Orla Busteded,
Frank Callanan, Pat Casey,
Sean Clarke, Eileen Coleman,
Paul Coughlan,
Brendan Courtney,
Kieran Cronin, Amy Cullen,
Sandra Currihan, Tim Curtin,
Michael Dawkins, Obioha Dike,
Garrett Doolin, James Duggan,
Yvonne Dunphy, Clwyd Evans,
Eddie Feely, John Griffin,
Emmett Guest, Jimmy Hally,
Susan Hammond, Neil Harrison,
Killian Hassey, John Healey,
Pat Hegarty, Charlie Hickey,
Pat Hogan, David Hull,
Michael Hurley, George Jordan,
Darren Kalsi, Eamonn Keane,
Bernard Kelleher, Eddie Kelleher,
Fiona Kelly, Mary Kenneally,
Tom Kenny, Redmond Keogh,
Pat King, Peter Langford,
Catherine Leahy, Diane Leahy,
Liam Luddy, Ria Lyden,
Austin Lynch, John MacCarthy,
Sinead Mason, Tom McCarthy,
John McCormick, Suzanne
McDonagh, Valerie McGrath,
Jerry Mehigan, Ciara Moriarty,
Barry Murphy, Billy Murphy,
Andrew Nixon, Joanna O'Brien,
Donal O'Callaghan,
Bertie O'Connell, Hugh O'Dwyer,
Brian O'Riordan,
Barry O'Sullivan,
John O'Sullivan, Tony Rafferty,
Maebh Reilly, Liz Roynane,
Malcolm Ryan, Billy Sheehan,
Oliver Smiddy, Grainne Wolfe

Architectural sub-consultant:
RKD McCarthy Lynch

*Cost engineering
sub-consultant:*
Bruce Shaw Partnership

Illustrations:
1, 2, 7, 8, 18-20:
Robert Bateman
3: Finbarr O'Connell
4-6, 9, 10, 12, 15-17:
Penny Rees/Daniel Blackhall
11, 13, 14, 21:
Janice O'Connell

21. Evening view of the link bridge between the production building and the finished goods building.



The Maggie's Centre, Dundee, Scotland

Forbes Winchester



1. The Centre commands beautiful views across the River Tay.

Background

The Maggie's Centre Trust is a charitable organization that aims to help people with cancer - and their carers, family, and friends - learn how to manage the physical and emotional impact of living with the disease.

The founder of the Maggie's Centres was Maggie Keswick Jencks, a close friend of the architect Frank Gehry until her death from cancer in 1995. The Centres are intended to provide a friendly environment, close in each case to a major cancer hospital treatment centre, which invites people to take time out and gives them a non-institutional place to call their own.

The new Dundee project is the third Maggie's Centre, and the first building designed by Frank Gehry in the UK. It sits in front of Ninewells NHS Hospital, Dundee, itself an Arup project of the late 1960s, and commands views up the River Tay toward Perth and across to north Fife.

The building

Gehry's most celebrated building to date is the spectacular Guggenheim Museum in Bilbao; in sharp contrast, the Maggie's Centre is very much on a domestic scale, with a floor area of 250m² and around the size of a large bungalow. It includes an information library, a kitchen, sitting room, large relaxation common room, and two small consultation rooms.

A two-storey feature tower dominates the Centre. Elliptical on plan, it bulges out from the base and then narrows toward the roof. It contains a small sitting room sited over the ground floor library. The roof of the remainder of the single-storey building is its primary feature, a series of folded plates that curve in three dimensions.

The roof is clad with stainless steel shingles that are intended to reflect clouds passing overhead, whilst its configuration was inspired by a shawl worn by the subject of Vermeer's 'Woman with a Water Jug'.

The roof structure is exposed internally throughout, and features curved beams and exposed timber columns to the kitchen external wall alongside the tower - the only straight wall in the building. Externally the walls are finished in white render, over which the substantial exposed roof timber overhangs afford some protection from driving rain.

Structure

The folded plate roof spans the width of the building, the profile of its ridges and valleys defined by primary beams made from curved *Kerto* LVL (laminated veneer lumber) beams. These beams consist of two 27mm thick and one 21mm thick sections of *Kerto* glued together in a jig to create the required horizontal profile, the vertical profile being subsequently cut into the assembled beams.

'It could have been a little straight box, but the softening of it, just with these slight curves, adds a warmth. We want to make these people that will come here feel special.'

Frank Gehry

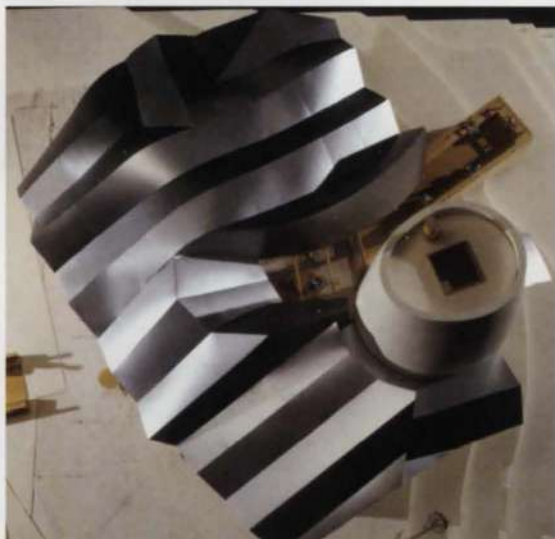

2. Architect's model showing configuration of folded plate roof.

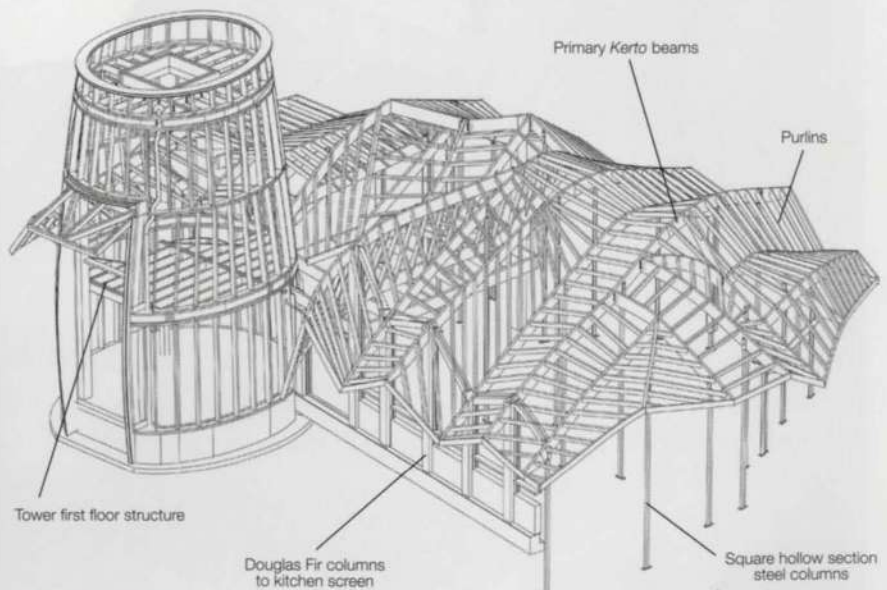

3. Details of timber structure.

The roof shape is further developed by hundreds of rafters spanning between the primary beams, at varying angles along each rafter. This further defines the curves of the finished roof. The end of each rafter required a compound mitre to be cut, every one of which was different. No two rafters are identical either. The carpenters had to mark out each saw cut using a bevel stock and for each cut use a sharp handsaw. The skeletal roof structure was then covered with two layers of plywood, screwed to both the purlins and the primary beams. The resulting composite structure is extremely stiff both horizontally and vertically.

The roof structure is supported by steel square hollow section columns located within the walls except for along the kitchen elevational glazed screen, where it is carried on 300mm x 300mm Douglas Fir columns. These are fixed at the base and provided with moment connections to twin Douglas Fir rafters, a configuration that gives stability to the elevation.

Stability for the remainder of the single-storey structure was achieved by tying the square hollow sections to the walls. These are all curved on plan, and are constructed in brickwork. This was for two reasons: firstly, some of the walls are to small radii which was not easily achievable in blockwork, and secondly there was a need to minimize control joints. To maintain uniformity of beam sizes, raking kickers were provided to minimize overhang deflections.

The tower was designed as a separate structure, inherently stable in its own right. It comprises a *Kerto* LVL timber kit frame which was dwanged (stiffened and supported) and plated externally with two layers of OSB (orientated strand board). The tower structure supports both the first floor of the tower and four roof beams from the single storey structure, thus tying both structures together.

The roof is weathered by a layer of bitumen, bonded with *Foamglass* insulation blocks which themselves incorporate a layer of bitumen. A further third layer of bitumen was then torched on to fuse all the bitumen together and fill any voids between the insulation. Stainless steel strips were then bonded to the bitumen perpendicular to the roof slope and another layer of bitumen applied. The stainless steel shingles were then cut and folded individually on site and anchored to the stainless steel strips.

The Maggie's Centre roof drainage is unusual in that there are no downpipes to the single-storey roof. The rainwater falls from the valleys to circular gravel collection pits contained within the landscaping, which in turn discharge to a field drain that overflows through a silt trap to the public drainage system.

Design process

Frank O Gehry as project architect, was responsible for the overall conceptual design, which he then developed through the use of physical models. These were digitized into a 3D computer model using a program called *Rhinoceros*, and an iterative process of further physical and computer modelling followed to refine the design. A full 1:25 scale model of the Centre was then constructed.

To turn Gehry's design into reality, the local practice J F Stephen was appointed as executive architect. It was Stephen's responsibility to obtain planning and building warrant consents for this unusual building. Arup then carried out the design of the structure, liaising closely with Stephen to ensure that the built reality followed Gehry's concept.



4 above. Connection detail between rafter, Douglas Fir column, and Kerto primary beam.

5 right. Complexities of the roof shown during erection.



6. The roof has a deep protective overhang.



7. Facing the Tay estuary, showing raised viewing platform in front of the kitchen, alongside the tower.



8. Common room.

Conclusion

Sir Bob Geldof officially opened The Maggie's Centre Dundee on 25 September 2003, following a complex 18-month construction period. During the first few weeks of operation the building has proved popular with users and is already regarded as a valuable asset in the treatment of cancer patients.

Credits

Client:
The Maggie's Centre Trust

Architect:
Gehry Partners LLP

Executive architect:
J F Stephen

Structural engineer:
Arup Scotland
Colin McCreath,
Stephen Lindsay,
Stewart Millar,
Charles Moodie,
Sandy Mowat,
Gavin Park,
Forbes Winchester

Quantity surveyor:
D I Burchell & Partners

Management contractor:
HBG Construction

Builderswork contractor:
Torith Ltd

Structural timber contractor:
Cowley Structural Timberwork

Stainless steel roof cladding:
W B Watson

M & E contractor:
D H Morris

Illustrations:
2: Gehry Partners LLP
3: Cowley Structural Timberwork
4, 5: Forbes Winchester
1, 6-8: Dave Robertson

Weblink:
<http://www.maggiescentres.org>

The Mondavi

Peter Balint Bruce Danziger



1. Mondavi Center front elevation at night: 'a beacon for the arts at UCD'.

Introduction

The Robert and Margrit Mondavi Center for the Performing Arts is the latest step in the progress of 'UC Davis Presents', a professional arts organization supported by the University of California at Davis. Until the Center was built, its regional and national shows were staged at various venues in the UC Davis and Sacramento valley area. To properly serve both University and region, an 1800-seat multi-purpose performance hall plus a smaller 250-seat studio theatre were needed. The design goal for the US\$54.3M Mondavi Center was a world-class, multi-use facility that would accommodate the full range, from orchestral concerts and dance to lectures and intimate theatre, and attract the widest possible variety of audiences and performers.

The design was thus driven by acoustic, theatrical, and architectural concerns. Acoustic performance and production flexibility were the fundamental objectives for Jackson Hall, the main auditorium.

Specifically, the target was an acoustics rating of NC15 and a stage appropriate for both large and small-scale events, maintaining in all cases a sense of intimacy between performers and audience. To achieve this, numerous moveable elements were designed to allow producers to change the size and shape of the stage while keeping the high acoustic standard.

The building's exterior creates an area that is, itself, a sort of stage, with an outdoor terrace adjacent to the University's arboretum. Natural materials were chosen, including light-tan veneer sandstone. The glass-walled lobby helps blur the line between exterior and interior, which is thereby opened up to outside view and becomes a glowing lantern at night, a beacon for the arts at UCD.

Integrating their disciplines so as to meld the disparate elements of a complex building, the design team of BOORA Architects and Arup as multi-disciplinary engineer (structural, mechanical, electrical, public health, and communications) was able to realize the University's dream and create a world-class performance hall.

2. Patterns of light and shadow fall across the outdoor terrace in the late morning sun.

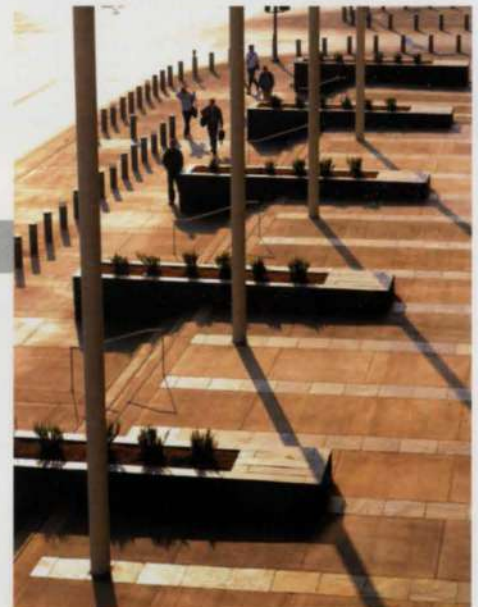

Mondavi Center

Paul Switenki John Worley



- A Existing alumni centre
- B Entry park
- C Orchard / vineyard
- D New campus entry drive
- E 700-car parking structure
- F 900-car surface parking
- G Mondavi Center
- H Performing arts administration building
- I Future hotel and conference centre
- J Future visual arts gallery
- K Existing arboretum
- L Existing agricultural test field
- M Underground reservoir
- N Colonnade

3. Mondavi Center location plan, terminated to the south by the 1-80 freeway.

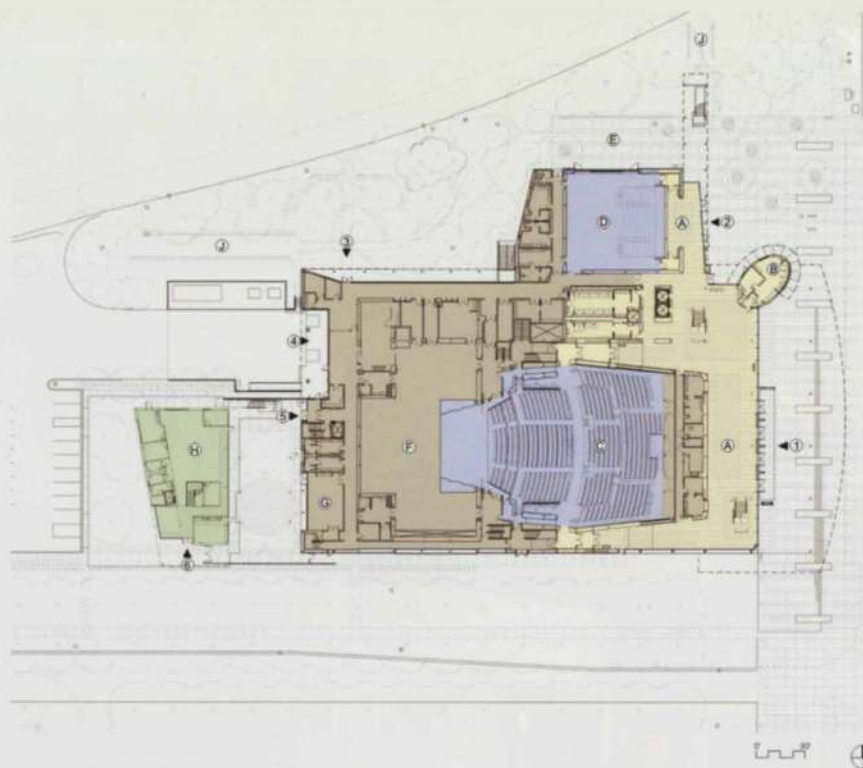

- 1 Jackson Hall entrance / porch
- 2 Studio theatre entrance / plaza
- 3 Student entrance / arboretum garden
- 4 Load in / service court
- 5 Artists' entrance/ artists' courtyard
- 6 Administration entrance / artists' courtyard gate

- A Lobby / front of house support
- B Box office
- C 1800-seat Jackson Hall
- D 200-seat studio theatre
- E North 'performance' terrace
- F Stage / back-of-house support
- G Green room
- H Administrative offices
- J Bike parking

4. Mondavi Center site plan.

Structure

A steel frame was deemed the most cost-effective and efficient for a facility with much geometric complexity. The challenge was to develop structural systems for the various elements that were simple and economical to meet tight budget requirements, but would not compromise the acoustic, theatrical, and architectural visions of this as a top-flight facility. This took a very high level of design co-ordination between the structural engineers and other members of the design team.

Central California being fairly active seismically, a robust earthquake-resistant system was needed, and a concentric tubular bracing system was employed to cope with the lateral loads due to earthquake. The structure for the main theatre and fly tower is primarily a steel skeleton around large open volumes of interior space, incorporating braces located to optimize seismic performance and allow for corridor, door, and window openings. The structural design challenge was to join and brace all the separate masses that make up this building (ie boxes, balconies, catwalks, follow-spot, gridiron, loading galleries, etc). Unlike a typical building with continuous floors at regular height intervals, the Mondavi Center contains many small floor slab areas at changing elevations throughout. Complex frame elevations were developed to co-ordinate brace locations and effectively grab each distinct level/mass.

A layer of soft soil with poor bearing strength underlies the site, and so deep foundations were needed to support the steel frame gravity and lateral loads. Noise and vibration from pile driving were unacceptable for the university environment, so cast-in-place drilled piles were chosen. These had to resist a large seismic base shear, together with the uplift forces associated with overturning from earthquake loads. Due to the interrelationship of pile depth, diameter, and spacing, the pile placement set forth in the foundation plan resembled a jigsaw puzzle. The solution required various sizes, from 24in (600mm) to 60in (1.5m) in diameter, and shaft lengths up to 60ft (18.3m), which took the pile tips well below the water table level.

Jackson Hall

To achieve the high acoustic standard, radical design measures were needed to mitigate noise and ground-borne vibration from the nearby freeway and rail line. The solution was the audience chamber designed as a 'box within a box' to obtain the desired acoustic isolation. The structure thus had to support twice the number of surfaces (two roofs, two floors, and two walls) with each surface having enough mass to keep exterior noise out and interior sound inside.

Steel roof trusses span 104ft (31.7m) across the hall, supporting a 6in (150mm) thick concrete roof slab and 6in (150mm) thick precast panels at ceiling level. The roof trusses are some 10ft (3m) deep and form an attic space above the hall for theatrical elements and the mechanical return air system.

The audience seating bowl is a suspended concrete floor slab on steel framing, to isolate the hall from ground vibrations and to accommodate an underfloor air supply system. Below the suspended floor is a slab-on-grade, detailed to dampen any vibrations from the rail line. The steel frame carries the hall wall of double metal stud sheeting, separated by a 2ft (600mm) air gap, which in turn supports sandstone cladding on the exterior and a combination of sandstone and plaster inside.

Another main design goal for the hall was to create an intimate environment for the audience and artists with excellent sightlines to the stage, so as to enhance the audience experience for all types of production. To this end the box and balcony fronts were designed in small segments, highlighting and inducing a sense of reduced scale into the auditorium. A series of long tapered cantilevers created these small box segments, which required back-span beams to weave through the tight circulation stairs and mechanical systems at the hall sides. Keeping the depth of these appendages thin while integrating the back-span elements through the hall sides was a significant challenge.

The desire for excellent sight lines to the stage required very thin structural elements to support the balconies and boxes. Thus there are two levels of balconies at the rear of the hall supported by a series of steel raker-beams cantilevering up to 24ft (7.3m), but all tapering down to a depth of 8in (200mm).

Structural analysis

An elaborate 3D analysis model (using the SAP program) was created to design the structure's earthquake-resisting system. The model included the entire steel frame of the building plus all concrete slab diaphragms modelled as shell elements. Dynamic analyses were run with the model to evaluate the dynamic behaviour and characteristics of this complex structure, and in turn were used to balance the stiffness and locations of the brace frames.

Tuning the torsional dynamic behaviour out of the system was particularly difficult due to the eccentric locations of mass such as the lobby floors and roof, which have to cantilever transversely to the main hall braced frames.

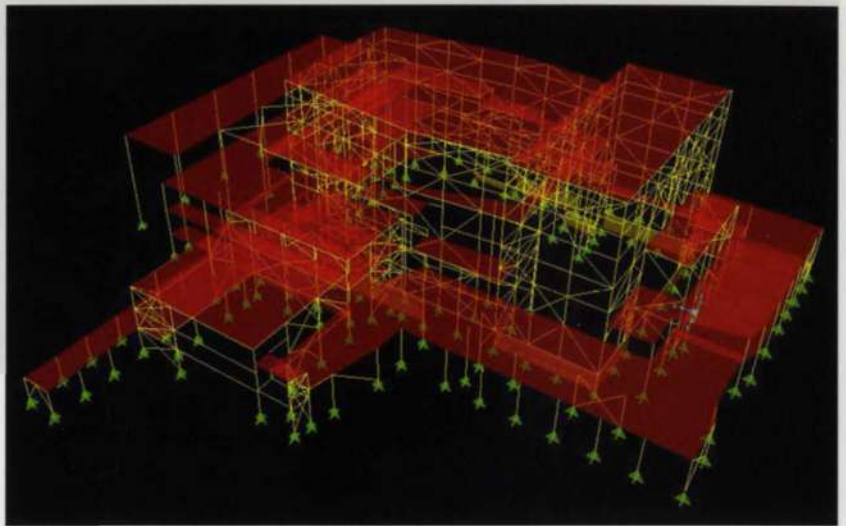

5. Wireframe model above: Shell elements modelled the diaphragm masses at the different levels.

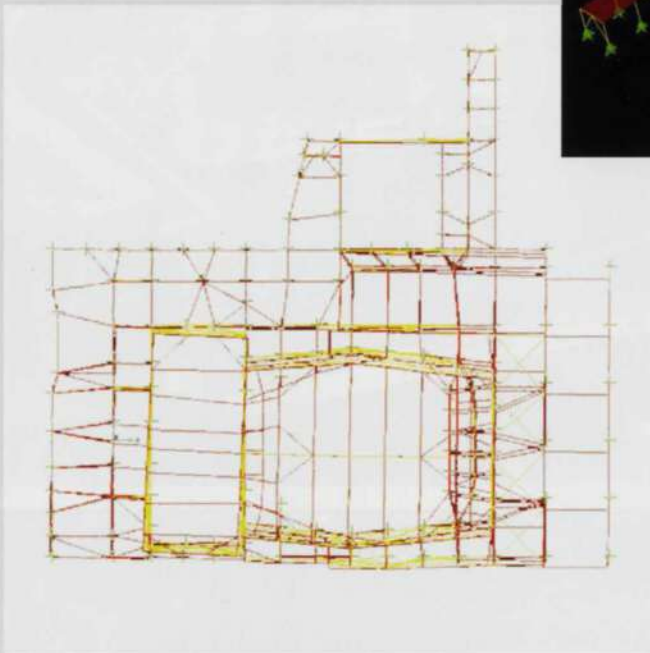

6. Plan view - Mode 1 deflected shape with mass accelerating transversely.

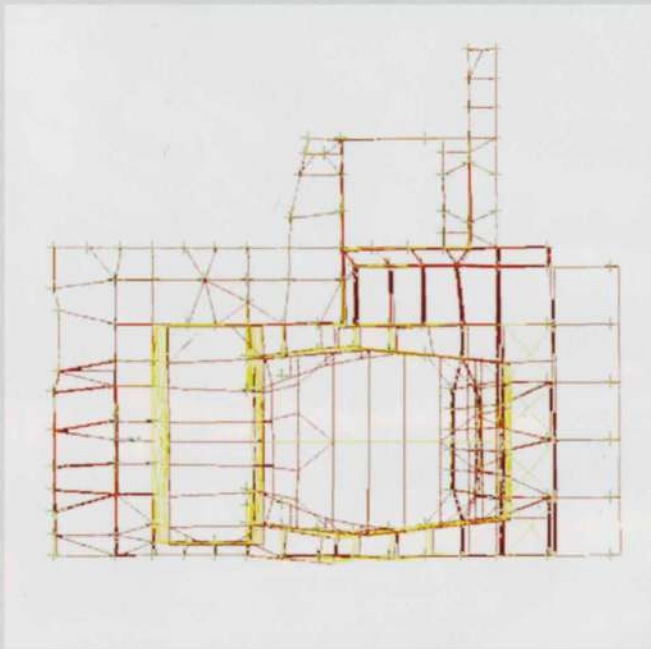

7. Plan view - Mode 2 deflected shape with mass accelerating longitudinally.

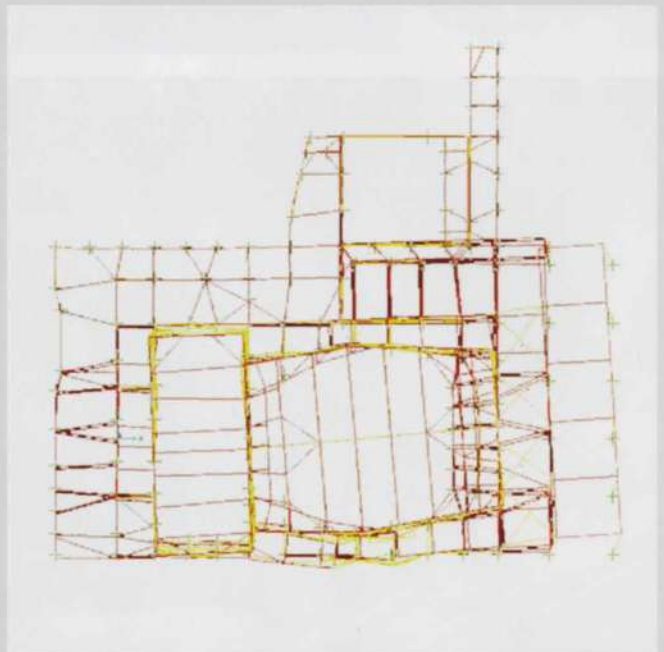

8. Plan view - Mode 3 deflected shape with mass accelerating transversely with torsion.



9 & 10. Jackson Hall interior view to stage from the lower balcony, and below from the stage to the auditorium.

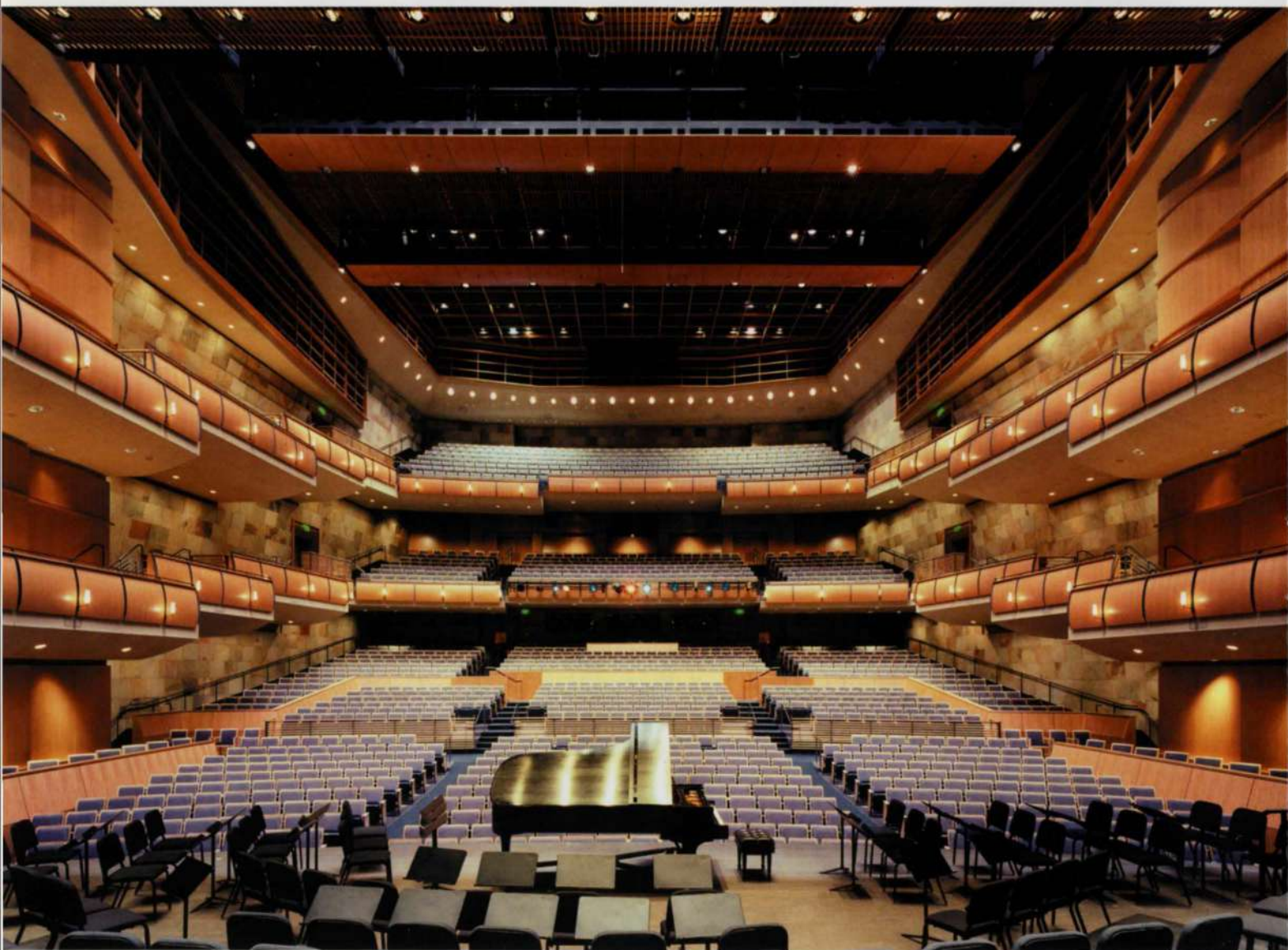

Stage

The stage structure was designed to accommodate the following movable elements for stage versatility:

- **The orchestra pit floor** can be raised and lowered by a series of electro-mechanical lifts, creating a deep forestage that allows an orchestra to play literally 'in the same room' with the audience.
- **Two large canopies** ('eyebrows') above the stage move up and down to change the height and shape of the stage opening. These measure 70ft (21.3m) x 30ft (9.1m) in plan, and are moved by a cable and counter weight system hung from the roof trusses.
- **The orchestra shell** can be moved into position to project sound into the audience chamber. This massive structure - 55ft (16.8m) wide, 41ft (12.5m) tall, and 20ft (6.1m) deep - weighs over 24 tons and is moved on 'air casters'. These are rubber bladders under the structure that literally float the orchestra shell on a cushion of air so that it can be pushed into its storage garage.
- **The walls to each side of the stage** ('cheek' walls) are shaped to help project the sound, as well as containing nine hidden movable door elements for performer and lighting access when needed.
- **The stage floor structure** was designed to accommodate a 40ft (12.2m) x 24ft (7.3m) removable trap area of which any combination of panels can be removed for scenic effects or actor entry. The stage floor is oak sprung, both to suit dancers and give acoustic resonance.

The stage fly tower can support any type of mobile production by the use of a 120 000lb counterweight system - 65 cables connecting to pulleys that raise and lower scenery, stage drapes, and lighting. In addition, a steel gridiron 80ft (24.4m) above the stage allows technicians to rig more special lines.

Lobby/exterior

The lobby's dramatic glass walls are supported by steel fin plates - 42ft (12.8m) long, 1.75in (44mm) thick, and 14in (356mm) wide - which hang from the roof structure and are restrained at grade level with a pinned connection that allows vertical movement. By suspending the steel plates in tension, resistance to lateral torsional buckling is enhanced. Seismic loading also demanded a robust structure parallel to the glass plane due to the potential acceleration of the façade mass in any direction. Slender steel tubes prop the plate at third points along the height, parallel to the façade. These tubes absorb the seismic forces parallel to the façade and also help resist twisting of the vertical plate.

The lobby structure clearly shows different levels connecting to the frame structure. The hall interior cantilevers for the balconies and boxes are reflected in the lobby and entrance structures. The exterior awning is propped by slender tubular steel columns and cantilevers horizontally back to the main hall braced frames. The lobby roof diaphragm also cantilevers horizontally to the main hall frames. The lobby floor at the first balcony level cantilevers away from the main hall and through the glass façade, creating an exterior terrace.

The series of lobby stairs are supported by exposed steel framing that create sleek sculpture elements for those viewing from the outside.

The main lobby stair, spanning 52ft (16m), is more sensitive to vibrations induced by footfall because its end supports rely on beams that function as part of a cantilever assembly. Deflections accumulate due to the flexible beam supports, thereby requiring very stiff stair stringers to avoid perceived discomfort caused by the movement of people on the stairs.

The egg-like architectural element devised for the box office and founders' room is an extruded elliptical form.

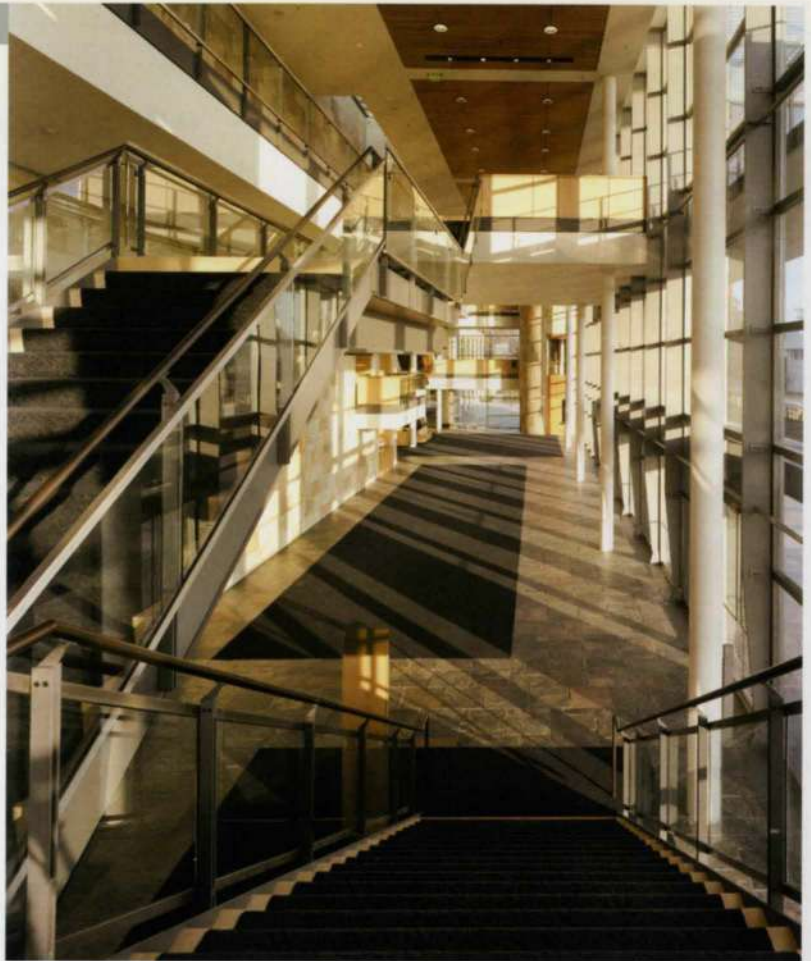

12. Front elevation at sunrise.

Braced frames were not acceptable due to the open plan of the egg, so moment frames with steel tubular columns and wide flange beams were used. The exposed vertical steel columns throughout the lobby area create a unified structural composition, but design of these moment frames was complicated by their interaction with the connecting floors, roof, and glass façade.

Supporting the exterior and interior stone cladding presented many structural challenges.

The stone, supported on a metal stud system, hangs off the structural frame. This support system needed to accommodate lateral in-plane movements during seismic events, which was complicated by vast areas of stone on the exterior wall, and the varying steel-frame skeleton of the structure.

Mechanical design

Five large air-handling units (AHUs) condition most of the Mondavi Center. Site constraints and the complex building geometry required them to be located on the back-of-house rooftop, immediately adjacent to Jackson Hall's exterior wall. Noise and vibration considerations were extremely important, and Arup worked closely with the manufacturer (Temtrol) to develop custom-built units. The supply and return fans are quiet, 11-blade, plenum-type fans, internally spring-isolated together with their motors. The units have 4in (100mm) acoustic lining and house internal sound attenuators. Coil face velocities are less than 400ft (122m) per minute to minimize pressure drop and fan energy consumption. Before being delivered to site, the AHUs were acoustically tested at the manufacturer's test laboratory.

The Mondavi Center is on a corner of the UC Davis campus, separated from the rest by Putah Creek, which all campus central steam or chilled water piping has to cross. Arup determined that it was feasible to run chilled water lines from the campus system, but provide on-site hot water from a stand-alone boiler plant in the basement mechanical room. The campus maintains 46°F (7.2°C) supply and 66°F (18.9°C) return chilled water temperatures, whilst the boilers provide 180°F (82.2°C) supply and 140°F (60°C) return hot water. The secondary hot and cold water pumps are variable speed.

Jackson Hall

The design team agreed that an underfloor displacement ventilation system would work well with the architecture, making additional use of the basement space already there to dampen train rumble, save energy, and create a quiet, comfortable occupant environment.

The displacement system introduces 35 000ft³/min (16.5m³/sec) of air directly under the occupants, whose body heat helps push the air upwards via natural convection. When the warmed air reaches the attic, it picks up more heat from the theatrical lights and is removed via return ductwork.

Due to this stratification, the system requires minimal supply air quantities and allows elevated supply air temperatures. The AHU economizer is able to spend more hours in 'free cooling' mode and reduce the burden on the campus central cooling equipment, thereby reducing chiller costs, pollutant emissions, and energy bills. Fan energy is minimized as the system offers very little pressure drop.

A further advantage of this system is that the supply air is in contact with the concrete structure below the seating, which allows the structure to act as a heat store. At night, cool air can be blown into the plenums to cool the concrete mass. The following day, the mass pre-cools supply air, further reducing energy consumption. The building operator can turn off the balcony supply air if partial occupancy is expected.

The acoustic consultant added flexible acoustic ductwork to assure train rumble would not make its way from the underfloor system through the diffusers and into the space. As a result the main floor plenum looks like a metal jungle (Fig 15).

Jackson Hall's space and noise limitations led to the selection of ceiling induction diffusers to cool the adjacent projection booth. Code-required minimum outdoor air is tempered and passes through the diffusers and their integral finned tubes. The chilled water in the tubes cools the air, which then enters the projection room and induces room air across the same finned tubes. A small inline pump circulates chilled water through the tertiary injection loop serving the diffusers. Certain methods of projection require dedicated projector exhaust systems. A small duct runs from the second balcony plenum to the projection room underfloor supply plenum. A wall switch activates the exhaust fan and transfer duct's motorized damper.

Similarly Jackson Hall's control room is cooled by a tempered outdoor air system coupled with chilled beams. This system proved even quieter than the projection booth's ceiling induction diffuser arrangement.

HVAC energy-reducing features

- The Jackson Hall and Lobby underfloor systems take advantage of stratification and higher supply air temperatures. Air changes and chiller energy are minimized.
- Fan energy has been minimized by designing low-pressure drop air systems. The underfloor systems are inherently low pressure systems and the ductwork is oversized to comply with noise requirements. Additionally, coils and filters are sized generously to minimize pressure drop within the AHUs.
- Variable frequency drives are used in many of the AHUs and on the secondary hot and cold water pumps.
- The boilers are high efficiency.
- The Mondavi Center's HVAC design beats California's stringent Title-24 Energy Standard by more than 10%.



13. Jackson Hall floor diffusers.

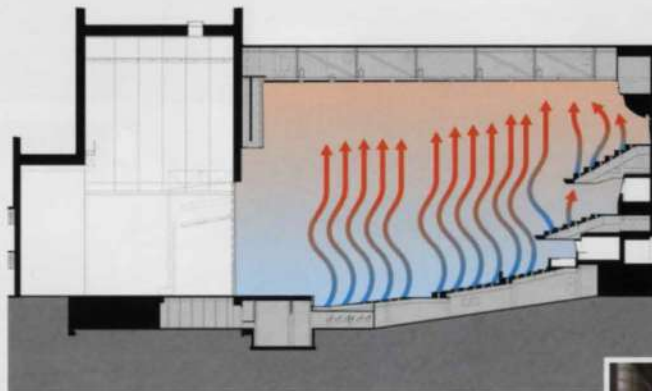

14 left. Air rises from the Jackson Hall underfloor plenum through floor vents.

15 below. Flexible acoustic ductwork in Jackson Hall underfloor plenum.



16. Balcony supply plenum co-ordination/integration; beam penetrations and floor diffuser openings.

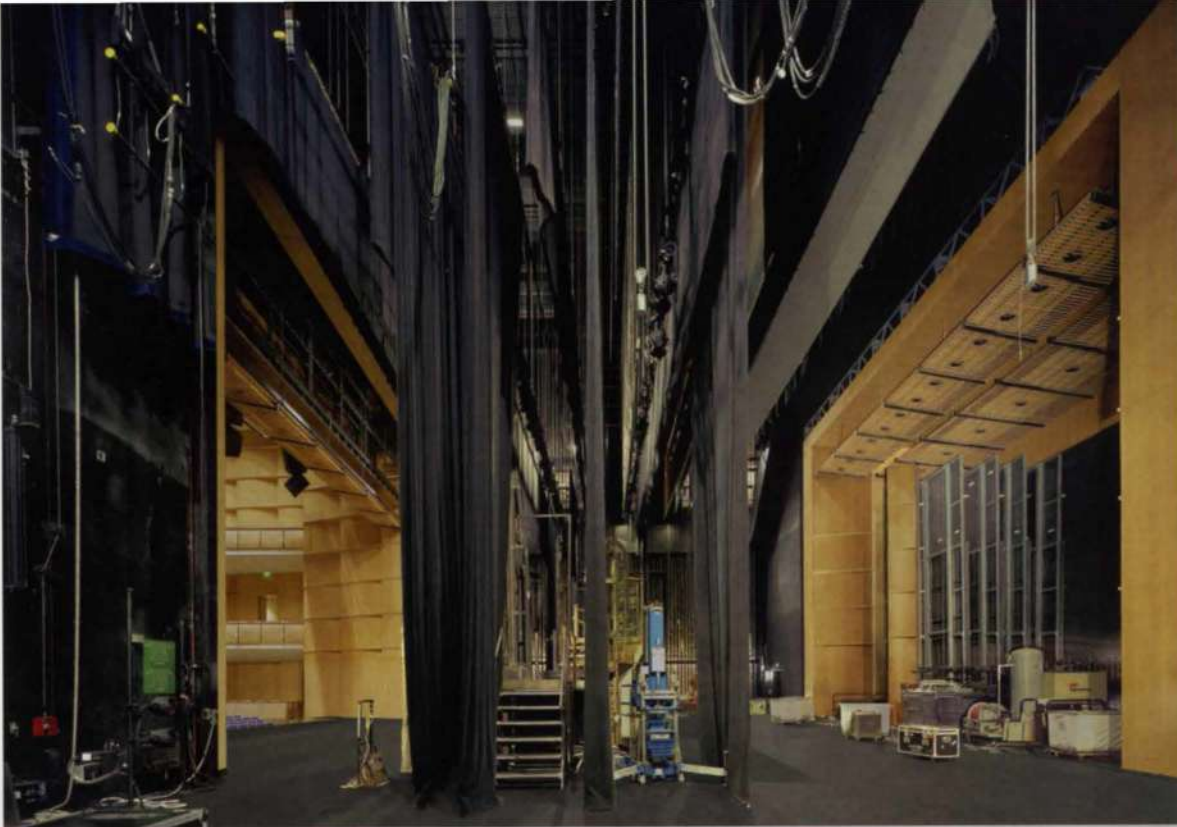

17. Jackson Hall backstage area.

Stage and back-of-house

The stage unit has a 15 000ft³/min (7.1m³/sec), constant volume system that drops cool air onto diffusion plates above the stage. These plates minimize the downdraft effects caused by supplying air from a high level and at a low velocity. A supply fan variable frequency drive overcomes increasing filter pressure while maintaining a neutral stage pressure. Local stage override means the system can be started for non-scheduled rehearsals or temporarily deactivated so as not to disturb theatrical smoke effects.

The back-of-house has a 14 000ft³/min (6.6m³/sec), variable volume (VAV) system that serves dressing rooms, corridors, the green room, building engineering, storage, and other performer support areas. VAV boxes are equipped with reheat coils and the unit has a supply temperature reset control to minimize simultaneous heating and cooling. Outdoor air is modulated to maintain minimum CO₂ concentrations, thereby minimizing conditioning of outdoor air during part-occupancy.

Musical instruments have recommended temperature and humidity levels for optimum preservation and performance. However, they must also move from storage into performance spaces and be allowed to adjust to the new (playing) environment, so the storage rooms are linked to Jackson Hall's environment via transfer grilles. When musicians arrive, their instruments will already be at or close to the on-stage conditions. The orchestra pit needs to be comfortable and unaffected by stage special effects, so two fan coil units pull air from the main auditorium and circulate conditioned air into the pit.

The supply air path is acoustically lined and integrated into the pit's concrete structure.

Lobby and exterior

A traditional overhead air system was considered but rejected due to the great height of the ceiling and difficulty in combating heat transfer through glass. Instead, Arup developed a low-level supply air system with vertical displacement diffusers near the elevators, circular swirl diffusers in the balcony floors and custom-manufactured, linear floor diffusers in the main floor. The latter consist of typical 'pencil-proof' grilles, backed by a perforated piece of sheet metal. This combination of grille and perforated metal sits atop plenum boxes at the lobby's perimeter, in line with the glass curtain wall support columns.

This location keeps the rest of the lobby floor clean and delivers air where it is needed most – at the perimeter glass. The columns and diffuser plenum boxes penetrate the lobby floor into a 5ft (1.5m) by 3ft (900mm) sub-floor trench that runs along the lobby's perimeter. Arup sized this trench generously as diffusers and plenum boxes presented the only significant floor system pressure drops. As a result, air distributes itself evenly amongst the diffusers. Four sub-floor volume dampers are the only elements included to simplify the balancing process. Approximately 26 500ft³/min (12.5m³/sec) of air is supplied via the low-level system and returned via ceiling grilles, ceiling plenums, and (minimal) return ductwork. Arup provided payback analyses to determine that the low-E insulating glass was the most cost effective glazing option.

The California Building Code regards the lobby as an atrium space. To comply with Code requirements for atria, Arup used rational analyses to design a smoke exhaust system. Upon detection of smoke, lobby doors open to provide nearly 125 000ft³/min (59m³/sec) of make-up air that combines with the lobby supply air. This air is removed at high level via fire-rated, rooftop exhaust fans.

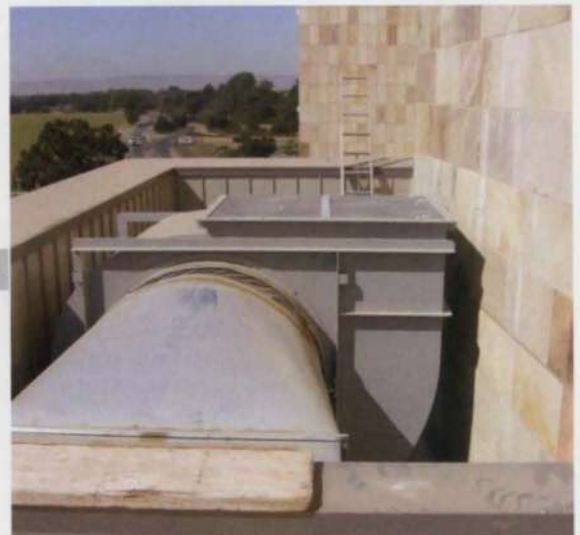

18. Lobby smoke exhaust fan.

a multi-level finned tube system, especially since the doors needed to open and close. A trench finned-tube system was discussed, but discounted for aesthetic reasons. Arup's solution was a radiant floor, with plastic piping laid atop the insulated, poured concrete floor base and in between the sprung wood floor sleepers.

This underfloor heating is complemented by an overhead, constant volume system, the two working in tandem to keep dancers warm in early morning winter workouts and larger crowds cool during summer recitals.

Electrical design

Electrical loads are high due to the Mondavi Center's multiple uses and the need to accommodate many theatrical lighting schemes, as well as power for travelling shows and fairly extensive catering facilities.

Also, the lighting and sound systems had to be isolated from other electrical disturbances so as to perform correctly. The fire alarm system had to alert occupants to any smoke detection or sprinkler system activation, to close off partitioning and stop smoke migrating, and initiate smoke removal should it be detected in the lobby atrium. Pathways had to be created for temporary cabling around the stage and to mobile television production facilities that could park behind the building.

Power is obtained from the UC Davis campus 12KV distribution system, with two pad-mounted transformers to serve the building. One transformer supplies a 277/480V switchboard for the building equipment, such as HVAC and elevators, as well as to feed the sound systems and miscellaneous user loads through step-down transformers. The second transformer is dedicated for the building lighting through its own 120/208V switchboard and dimmer rack.

The primaries of the main transformers were arranged in the typical UC Davis loop feed, with the back side of the loop coming from the campus back-up feeder. There were plans to add a small administration building behind the performance hall at a later date, so a space was left for a future transformer, with an in-and-out arrangement of the conduits to allow the loop to be continued.

Having two separate transformers allowed more separation between 'noisy' loads and the sensitive dimmed lighting loads. The main electrical room is extremely tightly packed and at a distance from the audience chamber, so it was decided to locate the dimmer racks and the switchboard feeding them at the front of the first balcony level.

This reduced the circuit lengths to the various lighting loads, but the proximity of the equipment to the stage and audience increased the noise issue.

This was solved by installing the dimmer racks on isolators and having all connections made with conduits that did not actually touch the dimmer enclosure, but had a small gap around each one.

The theatrical consultant asked Arup to install 'company switches' around the facility, particularly at various levels around the Jackson Hall stage and also in the studio theatre. These were intended to power equipment used by travelling companies, each of which has its own power requirements. The company switches varied in size from 60A to 400A, at 120/208V. A park in front of the Mondavi Center was also re-landscaped as part of this project, and two company switches were installed there to give outdoor performances lighting and sound systems.

As this is assembly occupancy, the fire alarm system had to include a voice evacuation system, with speakers and strobes covering the entire building including Jackson Hall. Locating the speakers and strobes in this large volume was a particular challenge, but the campus fire marshal was satisfied with the result. The fire alarm system is linked to the performance systems, so that the programme amplification is turned off before the fire alarm is sounded. A delayed action fire alarm system was considered during design, but this was not implemented as it would have put too much responsibility and liability on the security staff.

'The Arup team was selected because of their experience working with the architect, theatre designer and acoustician; they know how to work as a team and this proved very valuable for the Mondavi Center for Performing Arts project.'

They understood the complexities of this building type and brought innovative ideas and intelligent solutions. Arup staff were readily available during construction and were a pleasure to work with.'

Susan Rainier
University of
California Project
Manager

Awards

Portland
Chapter,
American
Institute of
Architects
Honor Award
People's Choice
Award

Portland
Chapter,
International
Interior Design
Association
Honor Award

Studio theatre

This posed some interesting HVAC design challenges. Measuring 60ft x 60ft x 40ft tall (18.3m x 18.3m x 12.2m), its north wall was to be dominated by two 20 ft (6.1m) square glass doors. These needed to be lightweight and were originally specified with a single thickness of glazing. Aside from presenting large heat losses, the glazing would promote a cold downdraft that would impact performers and audiences alike. Due to noise requirements, a forced-air convection system was not a feasible solution; nor was

Co-ordinated/integrated solutions

- Rooftop AHU layout
- Examples of structural co-ordination/integration

(1) Studio theatre

- ducts through studio theatre trusses, out of theatrical equipment zones
- radiant floor system with sprung floor, concrete slab
- adjustable acoustic panels above control room
- diffusers into acoustically-lined, architectural bulkhead
- tight ceilings in studio theatre front of house, lobby.

(2) Lobby

- ducts through beams (thin balcony structure)
- trenches (concrete, curtainwall structure, insulation, dampers, access, and diffusers).

(3) Main auditorium

- basement plenum (acoustics, structure, HVAC)
- temporary cabling required by travelling shows)
- attic (acoustical curtains, curtain boxes, roof trusses)
- balconies (seats, diffusers, structure) and ducts within balconies (routing to boxes, beam penetrations, curved overhangs, etc).

(4) Stage (crane rail beam)

(5) Back-of-house (shallow basement)

- many VAV ducts and boxes run within wall cavity, rather than exposed or within ceiling cavity.

(6) Main ductwork

- from concentrated rooftop plan, through building, into spaces, still reasonable pressure drops.

• Fire/smoke system

- (1) Automatic doors, smoke exhaust fans, lobby AHU, fire panel, smoke control panel.

• Acoustic co-ordination

- (1) Duct air velocity limits for breakout and duct-generated noise
- (2) Acoustic duct lining requirements
- (3) Balcony plenum duct route optimization: limit balcony plenum acoustic lining
- (4) Studio theatre adjustable acoustics
- (5) Control rooms.

Smoke removal in the atrium lobby was also a complicated issue. In addition to starting the smoke exhaust fans, the detection system also had to open the main lobby doors to allow sufficient make-up air to enter the lobby. The doors were power operated for normal remote operation and for handicap access, and they were also electrically locked at off-hours. The controls had to integrate between all these features to operate seamlessly and in a fail-safe mode, particularly in a fire situation.

A raceway system was installed, running from the loading dock through the basement and under the audience chamber to two separate points in the seating area. The intent was for temporary cables to power TV cameras recording the performance and relating to a mobile studio parked at the back of the building.

The biggest challenge was maintaining the integrity of fire-rated walls crossed by this raceway. The best available fire-stopping system, specified by Arup, comprises

intumescent blocks with holes to accommodate the cable, placed together in a metal frame, and locked down with a bolt. In a fire the intumescent block material expands and seals the hole. The entire assembly has to be assembled and disassembled each time new cable is installed.

Conclusion

Through intensive collaboration, the design team managed to accommodate the wishes of the architect, the client, the theatrical and the acoustical consultant, creating an arts facility that has exceeded all expectations. Launched with a gala concert by the San Francisco Symphony Orchestra on 3 October 2002, the Mondavi Center has been praised by public and performers alike. It manages to be eye-catching without seeming out of place, and has far surpassed the University's desires in terms of acoustic performance, energy-saving, the level of patron comfort, the flexibility it allows producers and set designers, and the calibre of performers it attracts.

Credits

Client:
University of California, Davis

Architect:
BOORA Architects, Portland, Oregon

Multi-disciplinary engineers:
Arup Simon Altman, Weng Ao, Peter Balint, Willie Batenga, Juanito Boado, Pam Brandon, Matt Craigon, Shantina D'Alanzo, Amelio Bulseco, Bianca Celestin, Larry Chambers, Eugene Chow, George Cheung, Judy Coleman-Graves, Lisa Cooper, Fiona Cousins, Matt Craigon, Shantina D'Alanzo, Bruce Danziger, Pompey Festejo, Susana Franco, Anthony Fresquez, John Gautrey, Oscar Gomez, Michael Hoffman, Jack Howton, Yee Huey, Lidia Johnson, Natalia Khaldi, Eric Ko, Peter Lassetter, Jun Lautan, Alla Lightman, Zeni Marchant, Jonathan Markowitz, Alisdair McGregor, John Moss, Cardenio Petrucci, Barry Ralphs, Benedicte Riis-Duryea, Cole Roberts, Pedro Romo, Mark Russin, Richard Spiese, Darren Sri-Tharan, Paul Switenki, Bryce Tanner, John Turzynski, Cress Wakefield, Tom Watson, John Worley

Acoustical consultant:
McKay Conant Brook, Inc

Theatrical consultant:
Auerbach Pollock Friedlander

Illustrations:
1, 2, 9-11, 12:
© Jeff Goldberg/Esto
3, 4, 14: BOORA Architects
5-8: Bruce Danziger
13, 15, 16, 18: Arup
17, 19, 21: Bob Canfield
20: Arup

Weblink:
<http://www.mondaviarts.org/>



20 above.
Opening day on
October 3, 2002.

21 left.
The busy lobby
during a
performance
intermission.

Simmons Hall, MIT

Julian Astbury

Leroy Le-Lacheur

Mark Walsh-Cooke

Introduction

Massachusetts Institute of Technology was founded in 1861 'for the purpose of instituting and maintaining a society of arts, a museum of arts, and a school of industrial science, and aiding generally, by suitable means, the advancement, development and practical application of science in connection with arts, agriculture, manufactures, and commerce'. MIT's commitment to innovation has led to many scientific breakthroughs and technological advances; 57 past and current members of the MIT community have won a Nobel Prize. A massive renewal programme, the 'Evolving MIT Campus' initiative, is under way to add 'nearly a million state-of-the-art square feet' to the campus. MIT's President, Charles M (Chuck) Vest, describes the programme as 'a mega-scale interdisciplinary research project... In the Institute's long tradition of innovation, I see our building programme as one of MIT's great inventions'.

Out of over a dozen individual projects, the first to be completed is Simmons Hall, a student residence. Its programme called for 350 beds with amenities including a dining hall, study areas, fitness centre, theatre, and café. The term 'open' is dominating the community-wide planning process, and for this student residence planners desired a welcoming building, open to light and air, with spaces designed to encourage intermingling between residents who, before Simmons Hall, occupied isolated off-campus apartments.

In early 1999 MIT appointed Steven Holl Architects to design the building. It would be the cornerstone in a masterplan developed earlier by Holl for a strip of new buildings lining Vassar Street on the campus. Holl's planning vision encouraged multiple penetrations along the strip to maintain views from an open urban green space to the north and to prevent the row of buildings from forming a barrier wall. Holl invited Arup to join the team; Arup New York would assume responsibility for the schematic and design development phases. Work would be transferred to the Boston-based associate architect, Perry Dean Rogers & Partners, with Arup's Boston office handling the construction documentation and construction administration.

Throughout the project, the design team had to balance the client's various interests and concerns. President Chuck Vest desired a landmark building in terms of sustainability and architecture. MIT's project management team had a clear mission to deliver the project on budget and on time.

The facilities group, responsible for MIT's heating and cooling plant, appreciated the sustainability goals but needed assurance that residents would be comfortable. Members of MIT's Building Technology Faculty required proof that the building's daring design would be successful and a symbol of pride for the Institute.



1. Close-up of the south façade, showing the operable windows in use by students in summer.

Steven Holl Architects envisioned the building as a 'sponge' with pores or openings. In early meetings, the architects and engineers actually handled sea sponges to explore how their order might be applied in some way in the design.

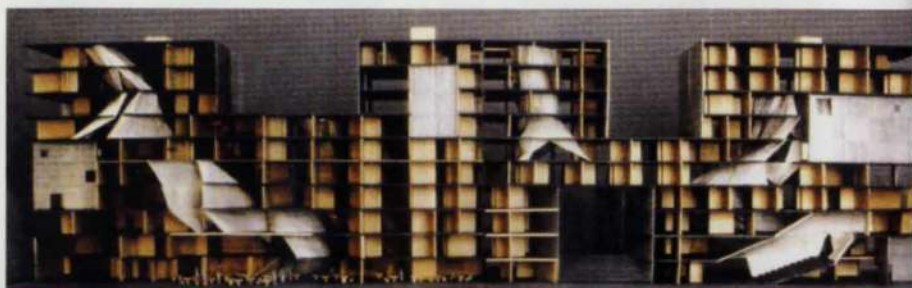

2. Early model, showing the 'porous sponge' concept and internal atria.

The concept

Holl envisioned the building as a 'sponge' with pores or openings. In early meetings, architects and engineers actually handled sea sponges to explore how their order might be applied in some way in the design.

It became a mantra to allow penetration of light and air into the heart of the building via a double approach: through elevations that consist of a porous grillage, and by embedding irregular and amorphous 'natural' open volumes to puncture and animate the repetitive floor plan of double-loaded dormitory corridors.

Simmons Hall is a narrow, 385ft (117.3m) long, 10-storey structure of 195 000ft² (18 100m²) gross area, where main entrances, view corridors, and outdoor terraces provide large openings. Small openings are in the form or more than 3000 operable windows – an unusual nine windows per single-occupancy student room. Larger windows correspond to common areas. Five curvilinear atria flow through the building's otherwise Cartesian grid. The 'porous' concept embraces programming and planning goals while allowing airflows and views over the nearby Charles River.

In the plan that emerged, architecture, structure, and building systems developed as an integrated whole. The exterior walls, designed by project structural engineer Guy Nordenson and Associates, are in a unique system dubbed *PerfCon* - prefabricated, perforated, reinforced concrete panels. The 2ft (610mm) square perforations house the operable windows. Each perforation's 18in (457mm) depth allows for low winter light to enter, while shading the rooms from the high summer rays.

Mechanical design

Simmons Hall presented a rare opportunity for Arup in the North Eastern USA. With 3000+ operable windows, inherent sun shading, concrete's stabilizing thermal mass, and the fact that student rooms would be less occupied during the summer months, the mechanical engineers were determined that their systems should be as economical as possible.

Using Arup's in-house E+TA software, the team conducted computer simulations to maximize the benefits of natural ventilation. Thermal analysis models took in all scenarios, including the fact that since each student room has nine operable windows, opening high and low windows can take advantage of the natural rise of warm air within the high-ceilinged rooms. Student rooms were designed with exposed concrete to keep the cooling load as low as possible. Models considered how the thermal lag of the concrete structure stabilizes interior temperatures.

The team first studied a natural ventilation scheme for one side of the building, with windows open but doors to the corridor closed. Using a design air temperature of 90°F (32°C) and humidity level of 50% RH, natural ventilation did not bring conditions in the student rooms within the zone defined in ASHRAE *Standard 55*¹. However, these initial studies proved promising for a cross-ventilation scheme. This brought temperatures and humidity levels into acceptable ranges, but cross-ventilation could not comply with fire codes. Though it was ruled out for the entire building, Arup and MIT designed a section of four rooms to simulate cross-ventilation's potential.

The added benefits of cross-ventilation in these test rooms can be monitored and documented by MIT's Building Engineering Department. Such research may lead to code-acceptable strategies for cross-ventilating high-rise residences.

Arup saw the opportunity to introduce an innovative 'mixed mode' system derived from concepts used in Europe. 'Mixed mode' is a hybrid arrangement that combines the mechanical cooling effects of a low-volume ducted air-conditioning system with the natural ventilation effects of opening windows. (In the USA, one reaps the benefits of such a system when one walks past the open doors of an air-conditioned storefront on a hot day.)

When MIT accepted Arup's idea, the Institute paved the way for Simmons Hall to be one of the first major buildings in the USA to use this system.

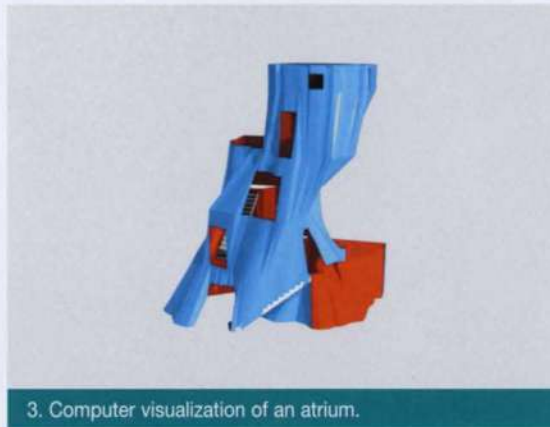

3. Computer visualization of an atrium.



4. South façade of Simmons Hall under construction.

During summer, students are encouraged to control natural ventilation using windows and blinds. 50ft³ (1.42m³) per minute per person, or 2AC/h (air changes per hour) of pre-cooled outdoor air is ducted directly to each room. In spring and autumn, the system can operate at varying supply conditions depending on inside and outside temperatures. In the winter, the system delivers 2AC/h pre-heated fresh air (at room temperature or a little higher depending on internal conditions) to student rooms. This guarantees high levels of air quality and eliminates the need to open windows for fresh air. The system combines with a low-temperature hot water radiator system that is the primary source of controllable heat to the student room. The quantity of conditioned air normally required by a space is reduced from 4-6AC/h to 2AC/h. Energy modelling conducted on Visual DOE Software shows 20% estimated annual energy consumption savings compared to an identical building with conventional HVAC systems, and 40% savings compared to the average energy consumption of this building type in the North Eastern USA.

The long, narrow Simmons Hall structure is divided into three sections ('towers'). With horizontal distribution extremely limited by the architectural requirement for high-ceilinged corridors, nearly all distribution occurs through carefully co-ordinated vertical risers. Arup designed an air-handling unit (AHU), one to be mounted on the roof of each of the three towers.

Outdoor air (pre-cooled and dehumidified in the summer to 65°F/18.3°C) is ducted from the AHU through risers adjacent to each bathroom extract - the only available vertical riser space.

Pre-cooled air is ducted to each room via insulated sheet metal risers and branch ducting just as with conventional air-conditioning infrastructure, but significantly smaller.

The mixed mode system offers inherent maintenance advantages. Three AHUs require considerably less maintenance than the 250 fan coil units in a traditional air-conditioning scheme.

5. One of the atria, extending up through four storeys to the skylight.



Residents have likened living in Simmons Hall to living in a piece of art... it is also a work of science to be studied and advanced in the future.

In student rooms, the risk of condensate drain overflow and the presence of movable components susceptible to tampering are eliminated. Also, there is no requirement for maintenance staff to access student rooms during summer months. Automatic seasonal changeover is initiated by a combination of internal and external temperature sensors. 16 temperature and 16 humidity sensors are located throughout the building.

When averaged, the sensors provide a general indication of building conditions to allow some optimization of the supply air temperature and humidity.

Atria and corridors share generally the same mechanical approach as student rooms. In the summer, mixed mode supply outlets at the base of the atria supplement natural ventilation. Corridors are naturally ventilated in the summer. In the winter, heated air is supplied into the top of the atria from the mixed mode AHUs. Supplementary hot water heaters service the body of the atria voids. In the corridors, the air from the atria's mixed mode supply is drawn along the corridors by the bathroom extract systems. During the spring and autumn, air at outdoor temperature is supplied into the atria and corridors as in winter and is combined with natural ventilation as needed.

Electrical design

Sustainable mechanical and lighting systems have reduced the overall connected building electrical load. Arup's electrical design was driven by both architectural intent and the high standards of MIT, whose central utility plant supplies Simmons Hall's electricity. The Hall takes two 13.8kV supplies into a double-ended switchgear arrangement. While the latter is more typical for a data centre than a residence, MIT has safeguards so that if one transformer is lost the other provides redundancy for life safety systems. From the switchgear, six busway risers - two for each of the three towers - distribute power vertically throughout the building; all primary distribution is vertical to accommodate high-ceilinged corridors. Of the six busway risers, three are normal risers and three are emergency risers. Arup's design includes two generators, another unusual choice for a student residence. MIT requires one generator solely for the building and one for the fire pump, which at Simmons Hall is part of a multiple set of pumps in the campus loop.

Arup designed a high-end analogue addressable system with full voice evacuation for fire safety. Engineers went to unusual lengths to ensure that the system and speaker placement met the world standard Speech Intelligibility Index (STI) method of measurement.

Arup has since worked with the National Fire Protection Association to include IEC 60849 'Sound systems for emergency purposes' in NFPA 72, the national fire alarm code; Simmons Hall was one of the earliest projects to meet this stringent requirement.

Plumbing design

Due to the urban setting, engineers were restricted with stormwater run-off and needed to limit the discharge rate to the sewer during heavy rainfalls. Normally, an underground retention tank meets this limitation, but Arup utilized flow-controlled roof drains that use a trapezoidal weir configuration to govern the flow rate from the roof - which depends upon the depth of the water on the roof.

Sprinkler protection

Simmons Hall is classified as 'high-rise', requiring higher residual pressures for the standpipe system than a low-rise structure. Sprinkler protection in the atria required a series of creative solutions.

At the atria's glass doors and windows, sprinkler water curtains were provided to ensure a two-hour fire rating of the glass. Within each atrium's walls, piping is routed in PVC - an unusual choice that enabled the piping to bend with the undulating walls, in turn requiring fewer swing joints. Additionally, since sprinkler heads are concealed within the irregular curves of the walls, their exact distribution needed to be carefully addressed.

Since there are typically no ceilings in the student rooms, the building is almost entirely protected by sidewall and extended coverage sidewall sprinklers.

In the congested basement service corridor, fire protection mains could not be located where standard seismic bracing could be used. This required specially-engineered seismic bracing for the fire protection systems throughout the 350ft (107m) length of the basement service corridor.

Fire

In the spirit of MIT's 'interdisciplinary research project', Arup performed early CFD smoke control studies for the atria that pierce the building. The team sought a fire-engineered solution that would allow corridors to be open to the atria, but all strategies other than the code-compliant approach proved too difficult or costly to implement. The most effective way to control smoke was to provide fire doors on hold-opens rather than active mechanical smoke control.

Communications

MIT and its students are demanding users of information technology and telecommunications (IT&T). Integrating IT&T infrastructure (rooms, routes and risers) seamlessly, transparently, into the facility, Arup provided support for high bandwidth digital communications in student rooms and common areas; wireless infrastructure to support mobile communications; and support for kiosks facilitating Internet access by students and guests.

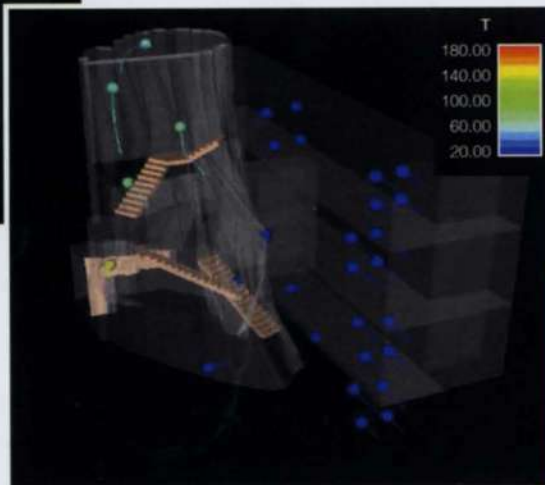
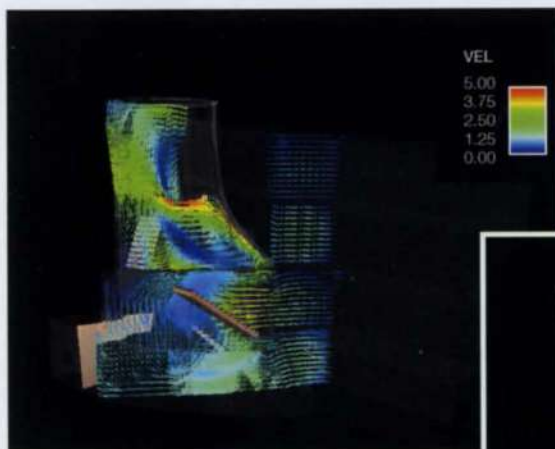

6 & 7 left. CFD models of velocity and temperature showed that, in principle, smoke could be extracted from the atria, limiting its flow from an atrium fire into the corridors. However, various constraints including getting supply air to the base of each internal atrium necessitated a code-compliant solution.

- Awards**
- American Institute of Architects (AIA)
 - 2002 New York Design Award and 2003 National Design Award
 - 2000 Progressive Architecture Award

Conclusion

Rarely in professional life are engineers granted the opportunity to innovate on such a large scale as in Simmons Hall. MIT asked its designers to improve social and aesthetic qualities of the urban landscape and to do so by promoting sustainable solutions for the future.

Since the building opened in August 2002, residents have likened living in Simmons Hall to living in a piece of art.

This building, where architecture, structure, and building systems impart one harmonious sustainable answer, is also a work of science to be studied and advanced in the future.

Reference

(1) AMERICAN SOCIETY OF HEATING REFRIGERATION AND AIR CONDITIONING ENGINEERS. ANSI/ASHRAE 55-1992. Thermal environmental conditions for human occupancy. ASHRAE, 1992.

Credits

Client:
Massachusetts Institute of Technology

Architect:
Steven Holl Architects

Associate architect:
Perry Dean Rogers & Partners Architects

MEP, fire, acoustics and communications engineers:

Arup Bill Ahearn, Jack Aroush, Aitor Arregui, Julian Astbury, Tom Beaudoin, John Boehs, Irina Bulbin, Danny Chan, Dale Cibene, Bernard Conroy, Steven Davidson, Gavin Davies, John Elissa, Gillian Gardiner, Gabriel Guilliams, Dennis Hromin, Carey Jones, Rebecca Kennedy, Lui King, Leroy Le-Lacheur, Susan Leven, Diego Lozano, Al Lyons, Anthony Goulding, Tom Grimard, Chris Marmon, Andy Passingham, David Powell, Mircea Preda, Ashok Rajji, Mahadev Raman, Joel Ramos, Anatoliy Shleygar, Peng Si, William Stevenson, Akiko Tanikawa, Nigel Tonks, Steve Walker, Mark Walsh-Cooke, Alex Yaroslavskiy

Design structural engineer:
Guy Nordenson and Associates

Structural engineer of record:
Simpson Gumpertz & Heger Inc

Construction manager:
Daniel O'Connell's Sons, Inc

Illustrations:
1, 4, 5, 8, 9: Andy Ryan
2, 3, 6, 7: Arup



8. Ground floor stairway.



9. View from the south east of Simmons Hall at night.

Transforming The City of Manchester Stadium



Martin Austin Stephen Burrows
Darren Paine David Twiss

1. The first full match: the friendly between Manchester City and Barcelona on 10 August 2003.

Imagine this as a brief:

'Take a 41 000-seat athletics stadium and transform it into a 50 000-seat football stadium in nine months. Also remove the track and seat the spectators close to the pitch so that sightlines are excellent. Oh and by the way, fit it out in full for use as a top English Premiership venue.'

*Impossible? No, but quite an achievement –
and that is what has happened at the City of Manchester Stadium.*

Introduction

The trigger for the creation of the City of Manchester Stadium was a single event, the XVII Commonwealth Games in 2002. Nonetheless, the terms of its creation¹ required it to become a legacy for the City of Manchester that is viable, iconic, and a catalyst for regeneration. The Games themselves took only 10 days in July/August 2002, but for at least the next 60 years the Stadium will be used by Manchester City Football Club, as well as acting as a 'neutral' venue in major cup competitions, and for occasional concerts.

The building was certainly iconic for the Games, but that very iconic nature was one of the things that underwent conversion. For example, the economics of the Games spectacle were driven by television, so there was the need

and opportunity for 'smoke and mirrors', as the opening and closing ceremonies and track finals were witnessed predominantly from home armchairs. UK Premier League football clubs, on the other hand, rely far more heavily on ticket sales for their income, which meant that some temporary facilities acceptable for the Games would not be acceptable for the Club.

Secondly, the regeneration potential of the Stadium could only be fully realised by making it a destination in itself within the City. Non-game day visitors are vital to attract the private sector investment needed to create the jobs, homes, community facilities, and programmes for sustainable urban regeneration of what was a deprived area of the city. Over the past year it has proved itself successful in this aim as well.



2. Arup Associates' architectural vision of the City of Manchester Stadium as a football venue.



3. The day after the Games concluded, transformation began.

4. Temporary seating being removed, 22 August 2002.



The task

The 2002 Commonwealth Games was an enormous success for Manchester and for the UK. 3679 athletes from 72 nations competed in 17 different sports across a total of 38 venues in and around Manchester, of which the largest was the Stadium. 900 000 tickets to events were sold, and 200 hours of live TV coverage were beamed globally from up to 38 BBC cameras. But the day after the Games finished the builders moved in and were soon removing the track (Fig 3).

Perhaps the most obvious element of the conversion from athletics to football was removal in less than six weeks of the 14 000 seats that occupied the northern part of the Games Stadium (Figs 4 & 5). Construction of the permanent North Stand began immediately and progressed rapidly (Fig 6).



5. left: Removal of temporary seating, 2 September 2002.

6. below: Progress on the North Stand, 21 January 2003.



Less immediately visible but equally challenging was the change from an athletics field to a football pitch. Athletics and football can only occupy the same stadium at the same level if the football spectators are seated a long way from the pitch. At Manchester this would have meant a million spectators per annum for the next 60 years having to accept poorer viewing positions because of a 10-day event in 2002.

This was unacceptable, so the football pitch was created 6m lower than the athletics field (Fig 7). This required the removal of 90 000m³ of material, equating to one lorry-load every two minutes of the working day during the excavation period. But the result is an intimate, even intimidating, gladiatorial arena embodying the atmosphere of a football club in contrast to the carnival style that was so clear during the Commonwealth Games.

The third, less obvious, major conversion concerned the need for the Club to derive revenue from its supporters. To maximize game day proceeds, there had to be tickets at all pricing levels with further opportunities for impulse buying. From the outset, Manchester City FC wished to transfer its existing business to the new Stadium and enhance it at all pricing levels. Furthermore, the venue has to have non-game day commercial uses far in excess of those on offer at Maine Road (the Club's former stadium) both to attract revenue for itself and meet the City Council's regeneration aspirations.

All this was also done within the nine-month construction programme by converting the shell used for the Games into corporate hospitality, concessions, restaurants, conference areas, shops, and kitchens for the Club's use.

The team

The military-style operation to complete the conversion relied heavily on co-operative and co-ordinated design and construction. Yes, the team knew this was to happen after the Games, and yes, it was planned for, but everyone also knew that in any interdependent activity, each party relies heavily on the other and so it proved here.

The team had two clients, Manchester City Council and Manchester City Football Club. There were two architects, Arup Associates and KSS Architects Ltd, and two contractors, for the shell conversion and for fitting out. There was, however, one engineer: Arup.

Since the Stadium had been originally built, some subcontractors had changed hands, some had new staff, some were not in sound financial shape, whilst some were as before. The common theme, however, was the drive and commitment shown by everyone in the team to make this conversion a success, and it is of enormous credit to all involved that this was achieved.

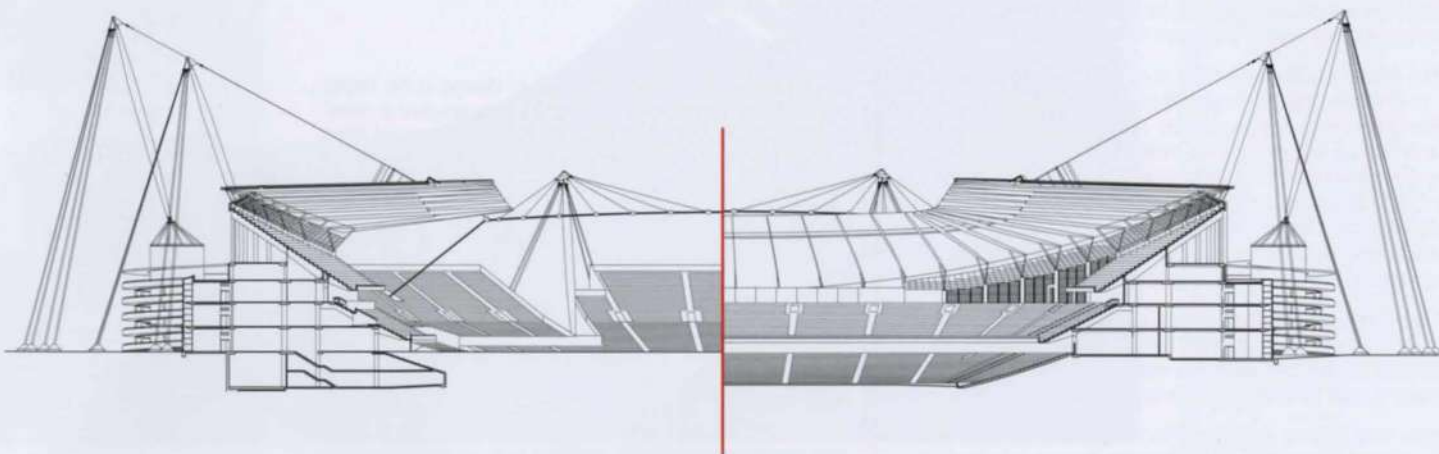

7. West-east section through the Stadium for athletics (left) and football (right), showing the lowered pitch level.

8. The curved bowl geometry generates spectator comfort and excitement.



The bowl

There were four key items in the conversion; the bowl, the roof, the Club facilities, and handover.

Within the bowl, the key issues were the pitch, the terraces, and the Club facilities.

Pitch

Clearly the playing surface is of vital importance to the Stadium's success for football. A good playing surface requires care and attention throughout its life, but without sunlight, airflow and temperature/water control it has been proved in many stadia that grass will cease to grow uniformly. Minimizing the risk of a poor surface was a key driver in the design decisions from the outset.

To maximize the amount of sunlight falling onto the playing surface, a 10m wide strip of translucent polycarbonate is provided in the roof on all four sides of the pitch. The cable net structure only intrudes minimally into this band and thus creates very little shadow on the grass.

The use of this material, often as a retrofit on stadia with grass growth problems, is well established but was not the entire solution for the City of Manchester Stadium.

The issue of airflow across the playing surface was solved innovatively. One would have thought that lowering the playing surface to some 6m below outside ground level would prevent airflow over the grass. And indeed it does pose a challenge, but the benefits far outweigh the problems. Sinking the bowl provides a lower profile stadium with the opportunity for a main concourse accessing the rear of the lower tier.

Not only does this give clear at-grade stadium access, but also creates the visual impact of looking down onto the action from the concourse - such a feature of Greek and Roman amphitheatres. When this geometric feature is combined with the toroidal roof form, the corners provide an opportunity for an adjustably perforated wall, allowing the Club to change the airflow across the pitch depending upon wind direction. This 'windy wall' is a unique feature of the building (Figs 8 & 9).

Finally, the surface itself. Grass grown from seed is known to be a much better playing surface than turf, because the surface is joint-free and thus more receptive to players' twisting and turning movements.

However, sowing a grass surface requires the seed to be planted at specific times of the year, and so a further key programme constraint emerged.

Football is a winter sport, and it rains in Manchester! So heating and draining the playing surface were also key factors. The pitch design includes below-surface heating and drainage pipework to enable the groundsmen to achieve an excellent playing surface. Its performance over the first five months of this season show that it is indeed in fine condition.

Terraces

Three of the four permanent stands were completed above ground for the Games, but none of the lower terrace was installed. After excavation of the athletics field was completed, construction of this lower tier was commenced. On three sides this tier, which seats 20 000 people, was simply cast onto a profiled and prepared earth surface, but on the west side it forms the roof of the players and match officials' facilities in the previously constructed basement.

Club facilities

Although the basement, which extends below the West Stand, was constructed for the Games, it was only a shell. In football mode this space contains the main kitchen, press rooms, player facilities, officials facilities, player warm-up, ground staff storage, and even a jail! Perhaps the most challenging aspect of its conversion was the kitchen installation, which provides meals for up to 6000 people on a match day. All meals are served in the two hours prior to the game commencing, resulting in not only a major cooking facility but also a significant logistical exercise for the staff.

The roof

Clearly a key element of the Stadium design is the cable net roof. The cable net itself was already erected in time for the Games and the temporary North Stand was fitted around the permanent masts and tie down cables. In fact, during the Games, the cable net was directly over the athletics track surface, which required Arup to obtain for the client a dispensation from the International Association of Athletics Federations.

Following the Games, the roof was completed by adding the rafters, purlins and cladding to achieve the final form and the intimacy that is such a feature of the building. This may appear a relatively simple task but cable nets are by their nature flexible structures, and joining two parts of a three-sided stadium together, and some considerable time after it was originally built, was not without its challenges. The sequence of loading and adjustment was carefully assessed and co-ordinated to ensure that the final shape meets the geometric aspiration. This involved considerable skill, expertise, and co-ordination between builder and designer.

Awards

2003

British
Constructional
Steelwork
Association
Structural Steel
Design Awards:
Winner

Building
Services
Awards:
Major Project of
the Year

Institution of
Structural
Engineers:
Structural
Special Award

Institution of
Civil Engineers:
Brunel Medal

Institution of
Civil Engineers
North West:
Merit Award

Manchester
Civic Society
Renaissance
Award:
Joint Winner

Association for
Project
Management
Project of the
Year:
Finalist

2002

British
Construction
Industry Award
Major Project
Category:
Highly
Commended

City Life:
Building of
the Year

Leisure Property
Forum Awards:
Major Leisure
Regeneration:
Winner

MSA Design
Awards:
Special Award

Club facilities

Fitting out a 50 000-seat football stadium in which some systems were already commissioned and had been used for the Games was also a feat of engineering and construction co-operation.

The Club commissioned KSS Architects Ltd to lead this fitout design for it and this involved all internal areas of the building. This £15M contract included the full mechanical, electrical, and public health engineering design for fitting out six hospitality suites, kitchens, pantries, Club administration offices, and concourse food, bar, betting and merchandizing concessions.

The services were designed to accommodate typical match days, with the suites providing banquet-style dining with restaurant menus, while on non-match days they have considerable flexibility to accommodate dinner dances, weddings, business conferences, etc. Decorative lighting themes were chosen for each suite to suit the aesthetics of the space, each being served from a dedicated mechanical plant. The electrical services were provided as a seamless extension to the base scheme services. Plasma TVs throughout the suites add to the spectator match experience. All services were fully co-ordinated within the base scheme services risers and plantrooms.

The fitout also included provision of communication cabling for voice/data services throughout the stadium and a fully automatic 'smart card' access control system for all spectators. The system is fully integrated with the ticketing system and has facilities for e-purse, cashless vending, and loyalty schemes.

Handover

Moving a football club from A to B is no small task, and to teach it how the new stadium operates at the same time adds further layers of complexity.

Arup recognized this and, to help the process, did two more key things: organized the relocation logistically, and helped to train the Club's staff in the building's operation. Arup's partner company, Rossmore Dempsey, is a management consultancy specializing in people-led process change, and its planning of the relocation followed the military precision of the construction operation.

Credits

Clients:
Manchester
City Council
Manchester City
Football Club

**Structural, mechanical,
electrical, public health,
civil, fire, acoustics,
geotechnical, transport
planning engineer:**

ArupSport and Arup
Associates
Simone Altmann, Martin Austin,
Mike Banfi, Fergus Begley,
Angela Bennett,
Gavin Blakemore, Mark Boyle,
Tony Broomhead, Nik Browning,
Mike Buckingham, Peter Budd,
Stephen Burrows, Peter Caller,
Graham Campbell,
Tristram Carfrae,
Eddie Carmichael, Bob Carville,
Richard Carroll,
Kevin Connaughton,
Ann Corrigan, Ben Cox,
Colin Curtis, Keith Dakin,
Paul Entwistle, Elsie Firth,
Michael Fyles, Penny Garrett,
Graham Gedge, Richard Greer,
Wendy Grant, Malcolm Gresty,

Enamul Haque, Dennis Harrison,
Richard Henderson,
David Hughes, Paul Hughes,
Ian Humphreys, Naushad Islam,
Andrew Jefferson,
David Johnson, Rich Johnson,
Lindsay Johnston, Lee Jordan,
Ulkem Karaca-Buckley,
Mike King, Phil King,
Chris Lambell, Andrew Law,
Tammi Lawrie, James Leahy,
Charles MacDonald,
Vivien McCullough, Will McLardy,
John McDonald,
Kate McDonald, Roger Milburn,
Richard Morris, Paul Murphy,
Donie O'Loughlin, Darren Paine,
Raj Patel, Dipesh Patel,
Annelise Penton, Judy Pierce,
Neil Phipps, Rachel Pickford,
Terry Raggett, Stuart Redgard,
Roland Reinardy, Marcel Ridyard,
John T Roberts, Ian Rogers,
Diane Scanlon, Mark Scull,
Martin Simpson, Jim Smith,
Caroline Sohie, Lexy Stevens,
Jeffrey Teerlinck, Patricia Thorpe,
David Twiss, Eugene Uys,
John Waite, Lisa Walker,
James Ward, Trevor Wheatley,
Gary White, Michael Wilton,
Andrew Woodhouse, Jason Yi

Design team collaborators:
AMEC Developments Ltd
C2C
Gillespies
KSS Sports and
Leisure Design
Manchester Engineering
Design Consultancy
Sports Turf
Research Institute

Quantity surveyor:
Davis Langdon & Everest

Construction manager:
Laing O'Rourke

Steelwork subcontractor:
Watson Steel Ltd

**Services and fitout
subcontractor:**
Haden Young

Illustrations:
1, 8: Denis Gilbert/VIEW
2, 7: Arup Associates
3-6, 9: Laing O'Rourke Ltd.

Training the Manchester City FC staff in the building's use permitted a smooth handover, facilitated licensing throughout commissioning, and culminated in the Club being ready to hold its first match in the Stadium against FC Barcelona on 10 August 2003 (Figs 1 & 8).

Conclusion

The aspirations of both clients for the City of Manchester Stadium were for a high class, sustainable facility that is economically reliable and a catalyst for regeneration. These aspirations have been met in full and often exceeded. The City of Manchester Stadium is now considered to be one of the best stadia in Europe, with its conversion from athletics to football completed on time and on budget despite the scale and complexity of the task.

Reference

(1) AUSTIN, Martin, *et al.*
Designing the City of
Manchester Stadium.
The Arup Journal, 38(1),
pp25-36, 1/2003.

9. Essential completion, June 2003.

The translucency of the roof and the closed corner vents contribute to spectator comfort as well as promote conditions for pitch growth.



Sustainability: Adding value to Investa Property Group



Katharine Adams
Cathy Crawley
Georgina Legoe

Corporate sustainability

Sustainability is emerging as a driver for innovation and competitiveness for all types of organizations and there is growing evidence that sustainability contributes to long-term financial success. Businesses that integrate sustainability principles into their corporate strategy can reduce risks and costs, raise employee productivity, create innovative products, and enhance brand equity.

Arup offers a range of integrated, sustainability-based, risk assessment and strategic consulting services that help organizations and their stakeholders to navigate this exciting sustainability journey.

A recent project has been that in which Arup Sustainability in Australasia assisted Investa Property Group (IPG) with the development of its sustainability strategy. Arup Sustainability's deep understanding of the property sector allowed it to work with IPG to provide greater definition and direction in integrating sustainability practices within the organization.

Investa Property Group

IPG is a fully integrated property group based in Sydney. It is primarily involved in office property investment, funds management, property and facilities management, property development, and the provision of corporate property services. Established less than three years ago, IPG has achieved rapid growth and increasing prominence within Australia. The company has a market capitalization that places it within the top 50 listings on the Australian Stock Exchange, where it is the largest entity in the commercial office sector.

IPG had already made a clear commitment to sustainability, and recognized that it was at the beginning of a challenging yet rewarding journey. Acknowledging the fundamental importance of protecting the environment and delivering safe workplaces, it had undertaken several sustainability initiatives in its buildings. It was the first listed property trust to obtain Sustainable Energy Development Authority (SEDA) ratings across its entire portfolio and to achieve the highest level (Five Star) occupational health and safety ratings from the National Safety Council of Australia (NSCA).



1. 60 Martin Place, one of IPG's commercial properties in Sydney, where Arup is also helping to optimize the façade refurbishment options.

However the company recognized that it needed a framework to link these activities with its business goals and strategic direction. To achieve this, IPG approached Arup Sustainability to help it identify what sustainability really meant to its business and to assist with the further integration of sustainability within the organization.

Analysis of sustainability position

As part of a highly consultative process, Arup Sustainability's Gap Analysis Tool was used to provide a comprehensive assessment of IPG's position in relation to key social, economic, environmental, and natural resources issues. It provided a 'snapshot' of IPG's existing data collection, monitoring and reporting systems, and the policies and procedures it had in place for managing sustainability issues. Future activities and progress can be measured against this 2003 baseline assessment. The presentation of the outcomes of the gap analysis in a highly visual format facilitated communication and understanding about sustainability within IPG.

Further analysis helped IPG to understand the challenges it faces in improving and recording sustainability performance across a range of sustainability issues. By identifying the areas and issues that IPG had not previously considered, Arup Sustainability was able to provide strategic advice to help IPG become a more sustainable organization.

'IPG believes that by distinguishing itself as a market leader in sustainability it is better positioned to attract and retain key tenants and minimize potential income leakage arising from vacancies.'

*Andrew Junor, General Manager, Asset Management,
Investa Property Group*



2. Cover for IPG Sustainability Framework.

Prioritization of sustainability issues

The gap analysis identified that several actions were needed for IPG to progress its sustainability credentials, but realistically only a certain number of actions were achievable or supportive of good business outcomes. Arup Sustainability worked with the company to justify and prioritize the issues identified in the gap analysis against IPG's five corporate objectives:

- financial efficiency
- corporate standing
- risk mitigation
- quality team
- looking after customers.

The prioritization process helped to identify the benefits and business case for IPG in implementing its sustainability strategy. It also provided a robust methodology for IPG to reassess its priorities in accordance with future needs.

Roadmap of sustainability actions

Once the sustainability issues had been prioritized, Arup Sustainability developed a range of strategic recommendations and helped assess the resulting opportunities for IPG to integrate sustainability throughout the organization.

This resulted in the creation of a strategic Sustainability Framework that both provides a practical roadmap for future actions to address the priority issues and serves as management reporting tool (Fig 2). Several of the resulting recommendations have been endorsed by the IPG Board and incorporated into the organization's balanced scorecard. For example, efficiency gains are a key performance measure for all new facility managers.

This structured approach has given the discipline required to identify the business benefits of the further integration of sustainability within IPG. The Sustainability Framework is designed to be a living document that will continue to change as IPG progresses along its sustainability journey.

3 right. Arup is façade and energy consultant for this new landmark office building in Sydney at 126 Phillip Street, developed by IPG and designed by Foster and Partners.

To be completed in 2005, it reverses conventional high-rise office design by moving services to the exterior and eliminating the central core.

The resulting large, uninterrupted floor-plates will maximize efficiency, effectiveness, and flexibility.



4 & 5. IPG asset managers in a workshop facilitated by Arup Sustainability to assimilate sustainability throughout the organization.



Integrating sustainability

Arup Sustainability is assisting IPG with the further integration of sustainability within the organization.

As part of this process the team recently ran an interactive workshop (Figs 4 & 5) for 30 IPG asset managers, with the aim of obtaining buy-in for sustainability and stimulating innovation in this area. A key component of the workshop involved the development of a Sustainability Charter for IPG's tenants, covering areas such as energy efficiency, water consumption, waste management, occupant comfort, and occupational health and safety.

Arup Sustainability would like to congratulate IPG on its recent inclusion in the global Dow Jones Sustainability Index (DJSI). Eligible DJSI constituents are identified and rated by Sustainable Asset Management (SAM), which analyses companies in terms of economic, environmental and social criteria.

See overleaf ▶ for example gap analysis and prioritization diagrams showing their application to hypothetical organizations. (Figs 6 & 7).

Sustainability gap analysis

Arup Sustainability has developed several industry standard and proprietary assessment tools to help organizations reap the added value that sustainability can bring to their businesses.

The team's Gap Analysis Tool (Fig 6) covers a broad range of sustainability issues and is based on the content of various key international standards and guidelines, such as the Global Reporting Initiative (GRI). The tool is designed to be flexible so that it can be adapted to address the specific needs of each individual client.

Detailed analysis of the strengths and weaknesses of an organization's approach to managing sustainability issues is complemented by an innovative graphic that effectively translates a complex concept into a simple visual output.

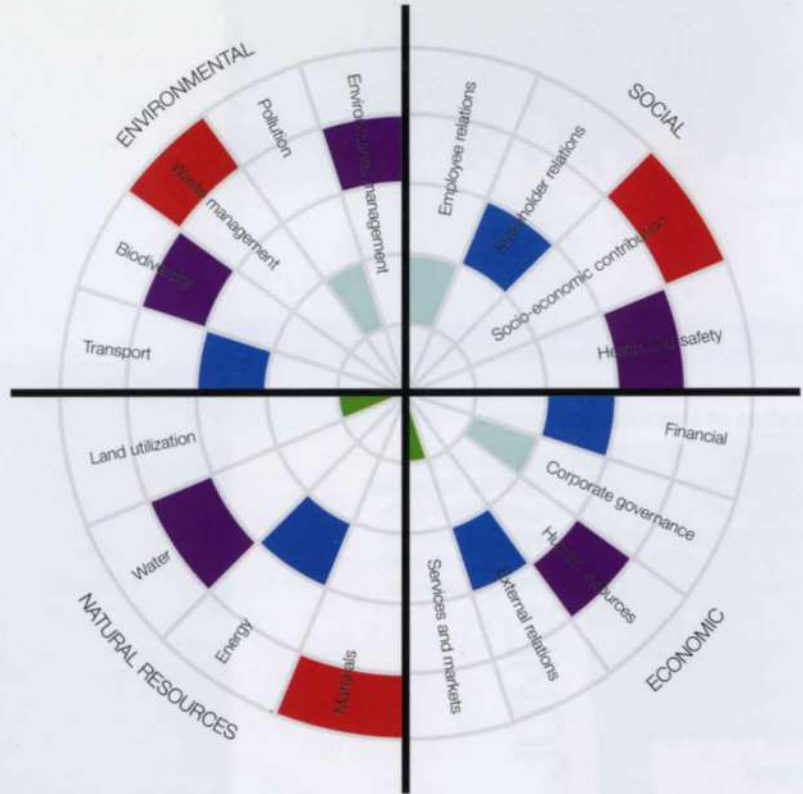

6. Example gap analysis diagram, showing the high level outcomes for a hypothetical organization.

Sustainability prioritization

Arup Sustainability's prioritization process (Fig 7) uses a risk-based approach to align the issues resulting from a gap analysis assessment against an organization's business objectives.

This incorporates a score for the potential opportunity for managing each issue, together with the likelihood of realizing that opportunity. Priority 1 issues are the most immediate, as they are the most strategically important to an organization's business. The 'level of ambition' for Priority 2 and 3 issues diminishes due to the peripheral nature of these issues.

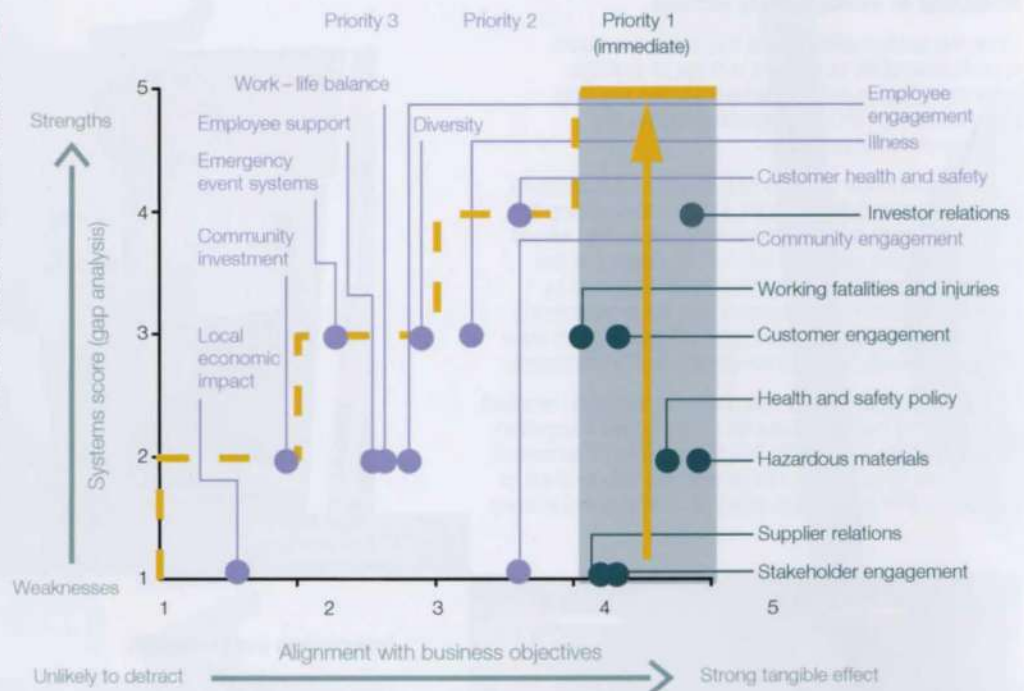

7. Example prioritization graphic of social sustainability issues for a hypothetical organization.

Detailed analysis of the strengths and weaknesses of an organization's approach to managing sustainability issues is complemented by an innovative graphic that effectively translates a complex concept into a simple visual output.

Credits

Client:
Investa Property Group
<http://www.investa.com.au>

Consultant:
Arup Katharine Adams, Jodie Bricout,
Natasha Connolly, Cathy Crawley,
Georgina Legoe, Debbie Maher

Illustrations
1, 2, 4, 5: Investa Property Group
3: Foster and Partners
6, 7: Arup Sustainability

SANE: Designing tomorrow's office

Tom Fernando

Background

There is an urgent need to adopt new perspectives for workplace design. Traditionally it has been location-centred and focused on single workplaces, but the development of information and communications technologies, the rapid growth of the 'information society', and the spread of globalization have transformed societies, economies, our ability to achieve sustainable development around the world, and the way we work. Workplace design thus should no longer be simply location-centred. Internet and mobile technologies make multiple work locations not only possible but often more congenial for a better work/life balance and business cost-effectiveness. It is important to understand location-independent work, so what are the factors that define a workplace in this context?

The European Commission R&D Programme 2000, drawn up by academia and industry in the EU, recognized this pressing need for 'new ways of working'.

It was therefore easy for a group of organizations from the UK and continental Europe to find a suitable niche within this programme for a project to define a framework for workplace design in the so-called 'new economy'.

Thus was born SANE (Sustainable Accommodation in the New Economy).

Project team and budget

The multidisciplinary SANE consortium - Arup, DEGW plc, Royal Holloway University of London (UK), Institut Cerda (Spain), IAT, FAW (Germany), and Telenor AS (Norway) - brought together a wide range of expertise from academia and industry (Fig 1) relevant to designing the workplace of the future. The proposal, like all such for part-funded EC projects, went through lengthy evaluation amongst thousands of others competing for the same pot of EC funds, before a contract was awarded in December 2000. The project was to last two years and involve more than eight person-years of effort. It had a budget approaching 6M euro, the EC providing just over half of it and the remainder contributed in kind by the industry partners in the SANE consortium.

	Architecture	Human sciences	Science and engineering	Information technology	Environmental technology	Business management
Arup (UK)			▲	▲	▲	
DEGW (UK)	▲	▲				
FAW (Germany)	▲		▲	▲	▲	▲
IAT (Germany)		▲	▲	▲		▲
Institut Cerda (Spain)			▲	▲		▲
RHUL (UK)	▲	▲		▲		▲
Telenor (Norway)		▲	▲	▲		▲

▲ Industry ▲ Academia ▲ Industry/Academia

1. The SANE consortium partners.

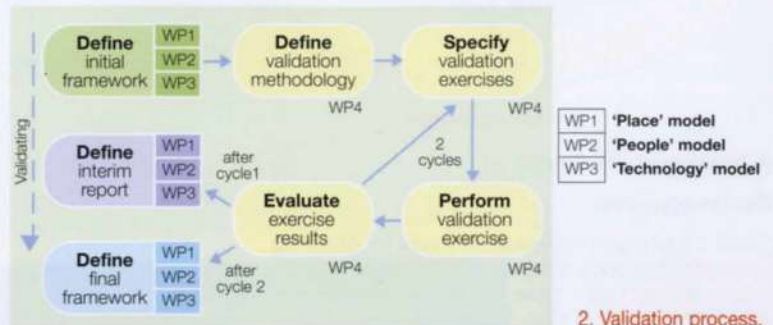

Project method

The project's basic premise was that for the design of the workplace to be comprehensive, three key 'environments' or aspects of it must be considered: people, process, and place. The study of these leads to three frameworks or 'models':

- human (or people) environment model
- technology (or process) environment model
- place (or space) environment model.

These environments would be studied using appropriate methodologies: for 'place', an extensive survey of workplace users supplemented by real life tests; for 'human', ethnographic surveys of workers in real life; for 'process', the introduction of technology in the workplace tested by means of real-life experiments. Unification of the three models would embrace a variety of modelling technologies. A key facilitator in the investigations was work in real life, and 'validation exercises' (Fig 2) played a key role by providing a locus for obtaining data and validating the models and their integration. Two cycles of validation were used in the two years, with an interim unified framework produced at the end of the first cycle, and the second cycle culminating in a final unified framework.

In the project's first year, real-life work environments were studied in five of the partner organizations in Germany, Norway, Spain, and the UK. An advanced package of processes and tools for use in the workplace was developed during this period, the real-life experiments helping to flesh out the three models. Attempts were also made to unify the models as far as possible.

In the second year, the package of processes and tools tested in the first year in the largest real-life experiment - setting up Telenor's new HQ in Oslo for 7000 staff - was deployed in five partner organizations so that the common backdrop would permit study of variations in culture, organization type and size, business processes used, etc. The three models and their unification developed in the first year of the project were also tested.

Arup's contribution

Arup Communications, as in previous research projects for the EC - BRICC (Broadband integrated communications for construction)¹ and CICC (Collaborative integrated communications for construction) - represented Arup in the SANE consortium. As a key founding partner, Arup Communications led the pivotal work-package that co-ordinated validation of the framework for workplace design, as well as being one of the five that hosted a validation exercise or real-life experiment that provided a locus for gathering empirical data and conducting ethnographic studies on knowledge working.

Arup Communications also made substantial contributions towards developing the technology environment model. Arup Environmental also contributed, supplying the main input on sustainability aspects of the workplace of the future for developing the place environment model.

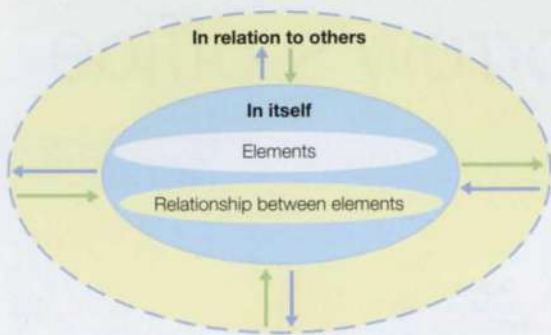

3. Inter-relationships.

A framework for design

Design objective

SANE's goal was a framework or model for designing the workplace, comprising various elements in some relationship with each other. The description of the inter-relationships between the elements should give an integrated or unified framework (Fig 3 above).

A statement of results in terms of a unified framework was particularly useful to the SANE participants, but it should also address the interests and concerns of others outside the consortium, satisfying the needs of the broader public interested in workplace design. A SANE model would be able to fulfil this wider goal only if there was some validation of the model within the project itself. The model had to be validated both in itself for its own internal consistency and coherence, and in relation to others by testing its applicability and utility (Fig 4).

4. Validation.

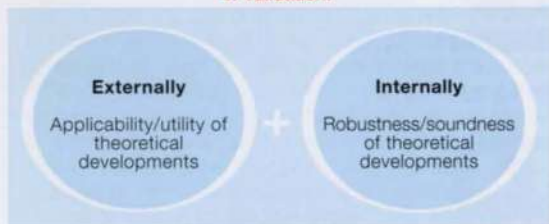

Design users

The end-users of workplace design are businesses - the ultimate client addressed by the SANE project. Even though a comprehensive framework for workplace design must consider the three aspects of people, place, and process, different parts of a business tend to focus on one or other of these. 'Place' touches all parts of a business, but its provision and maintenance are usually the remit of corporate services and general administration. Similarly, 'people' are everywhere in an organization, but the human resources group has a more focused interest in it. Equally, 'process' permeates the entire business, but mainly operational groups concentrate on it. All parts of a business have some interest in all three aspects, and the emphasis on the interests of any particular part depends on organizational strategy (Fig 5).

5. Areas of interest.

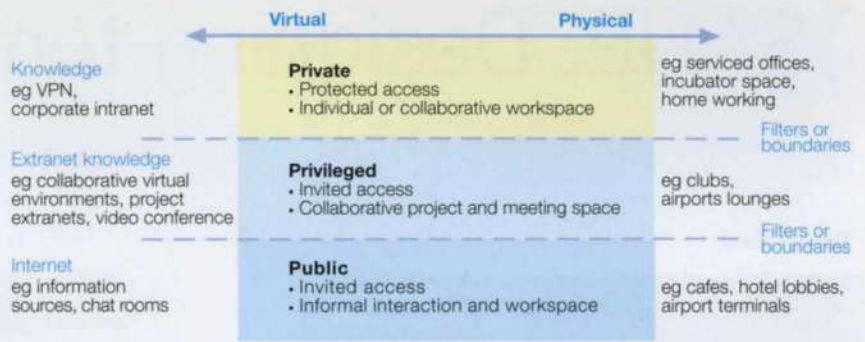

6. The 'meso' model for workspaces.

The 'place' perspective

A 'meso' model

The study of 'place' in SANE resulted in three models, the first of which covers a spectrum of particular workspaces based on the twin concepts of autonomy and privacy that apply primarily to working people, but are also relevant to work processes.

At one end of the spectrum is the private workspace with protected access, at the other the public workspace with open access. Between these two extremes lies the 'privileged' workspace where there is invited access. The model can be extended to cover physical and virtual workspaces (Fig 6 above).

A 'macro' model

The second 'place' model covers the whole spectrum of geographical spread in organizations as well as ownership of the premises. At one end, the entire business is co-located in a single office entirely owned by the business. The next stage is the business geographically distributed but still retaining complete ownership of all premises. Beyond this, the business is geographically dispersed so that it owns only some premises and shares others with other businesses.

At the far end of the spectrum, a business is geographically dispersed, does not own any premises, and shares them with other organizations (Fig 7).

7. The 'macro' model business location and ownership.

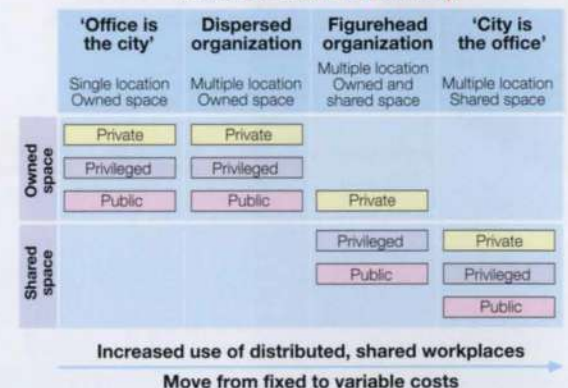

A 'pico' model

The third 'place' model is a taxonomy of workspace environments. Items of furniture and tools are elements that can be variously combined to form a 'work setting', which itself can be embedded in a larger functional 'work arena'. In turn, the latter can be part of a wider functional area called a 'work environment' (Fig 8 right: facing page).

A taxonomy of place

The three 'place' models taken together provide a taxonomy of workspaces in terms of key aspects of place relevant for workplace design: functionality, autonomy, privacy, geographical distribution, and ownership. The taxonomy can be used to design workplaces.

The project also came up with a workplace design consultancy model, where this taxonomy could be utilized for workplace design.

The 'people' perspective

Study method

Investigation of the 'people' aspect in SANE was based on the 'common ground' approach in communications theory. However, in itself this was insufficient to cover the broader aspects, so an 'extended common ground' approach was used in which communication events are analyzed in terms of 'communication frames'. Each of these has several key parameters: agent, topic, activity, setting, and resources. During communicative events, these parameters change and new frames come into being.

The study of 'people' in work had key links to 'process' and 'place' aspects investigated elsewhere in SANE. Typical contemporary 'knowledge workers' were observed and interviewed and their collaborative activities analyzed in terms of communication frames to identify regularities and build models for 'people' in work.

This study resulted in a model showing key parameters and relationships applicable to 'synchronous' and 'asynchronous' communications. The importance of 'gatekeepers' for asynchronous communications was a key finding in these investigations (Fig 9).

The 'process' perspective

Study method

The study of 'process' in work in SANE focused on the introduction of new technologies in the workplace. Technology exists in distinct elements, which can be used alone or in conjunction with others in several, not necessarily predefined, ways to fulfil functions (Fig 10).

Thus combinations of elements allow technology to support functions, which themselves, singly or in combinations, provide technology 'affordances'. Affordances are functional in the sense that they are enabling, as well as constraining, factors in a given organism's attempt to engage in some activity. In brief, the introduction of technology implies the introduction of new functionality sets or affordances (Fig 11).

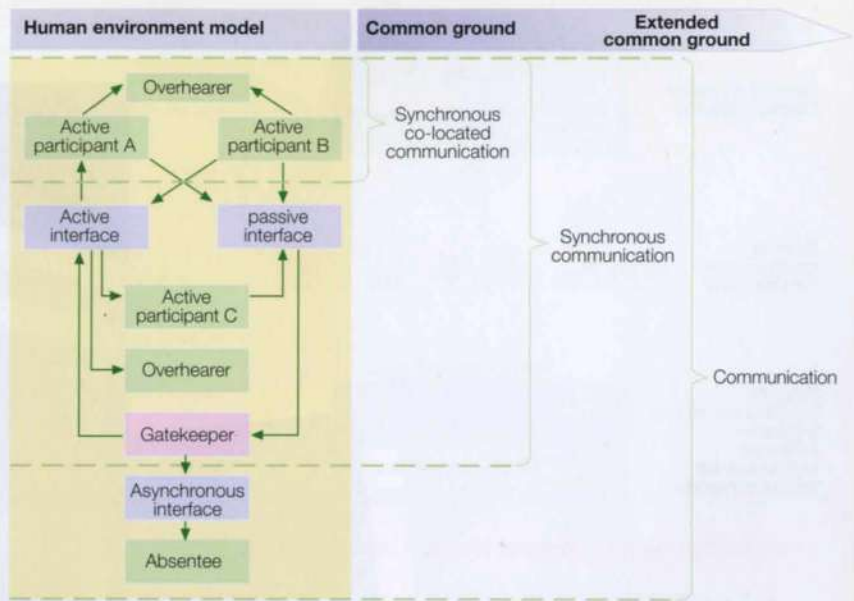

9. 'People in collaboration' model (© RHUL, 2002).

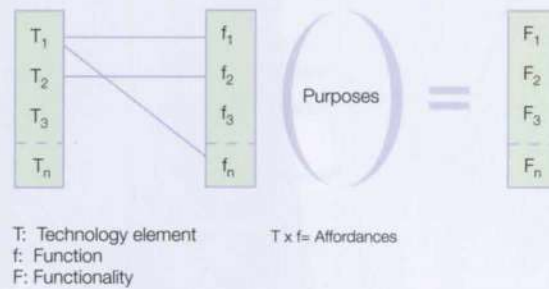

10. Generic technology context (© Universität Stuttgart, 2002).

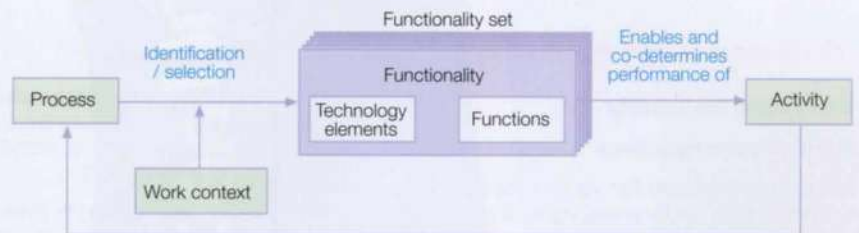

11. Functionality model.

Work setting elements	Work setting	Work arena	Work environment
<ul style="list-style-type: none"> • Desk • Table • Chair • Filing cabinet • Plant • Power • Wall • Partition • Task light • Down light • Telephone • Computer • Network • Whiteboard • Data • Printer • Photocopier 	<p>Physical</p> <ul style="list-style-type: none"> • L-shaped desk & chair • Small table for three • Large table for six • Sofa • Quiet area • Browsery • Seat <p>Virtual</p> <ul style="list-style-type: none"> • Video conference • Instant messaging • Shared visualization • Chatroom • e-whiteboard • e-mail • VR world/avatar • Text message • Voicemail 	<ul style="list-style-type: none"> • Team/project area • Business lounge • Club • Cafe • Picnic area • Meeting room • Meeting area • Individual office 	<ul style="list-style-type: none"> • Organization office • Serviced office • Business centre • Airport • Railway station • Street/City • Park • Transport (train, plane, car) • Home

8. The 'pico' model of work environments.

Mechanisms model

Functionalities are introduced in the context of a particular organization, and so several mechanisms have to be used to implement a functionality set in an organization (Fig 12 overleaf).

Analysis of experiences during the SANE project led to the following typical mechanisms being formulated:

- relevance for work activities
- individual preferences
- good user interfaces
- beneficiaries
- implementation processes
- 'domestication' of technologies
- compatibility with existing processes, tools, and competences
- network externalities/critical mass
- institutional decisions
- path dependencies
- different time-scales of decisions and processes
- unintentional side effects.

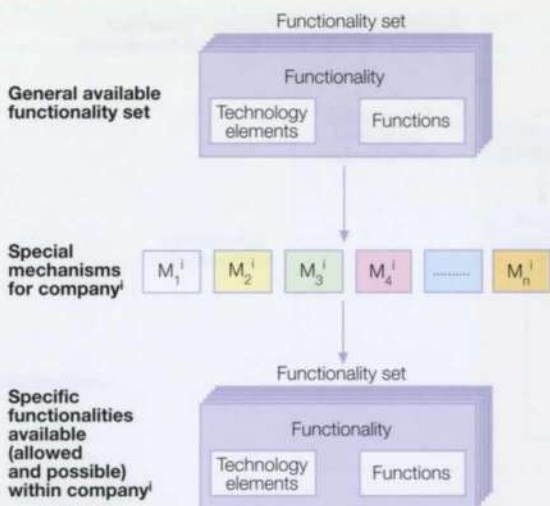

12. Mechanisms model (© Universität Stuttgart / Telenor, 2002).

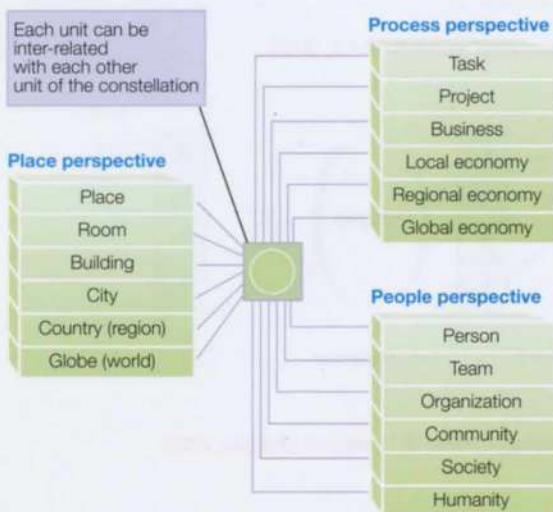

13. Inter-related perspectives (© RHUL, 2002).

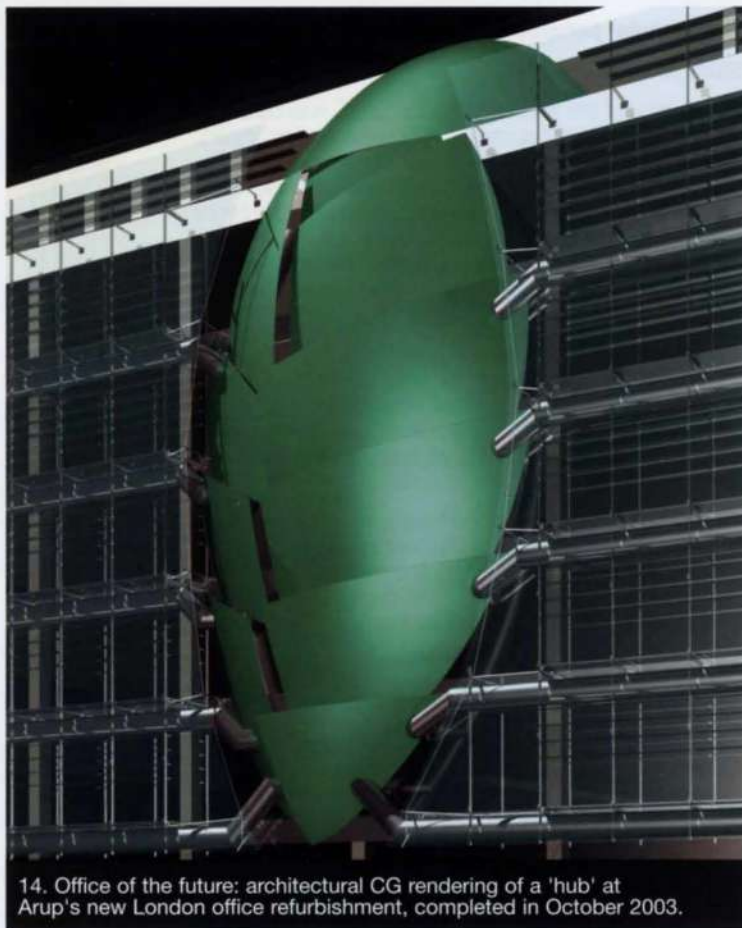

14. Office of the future: architectural CG rendering of a 'hub' at Arup's new London office refurbishment, completed in October 2003.

Integrating the models

Interrelated perspectives

Studies demonstrated that each of the three perspectives - people, place, and process - is itself multi-layered or multi-faceted. The investigation of any one perspective could not be carried out without considering all layers within, as well as all three taken together (Fig 13).

From the 'place' aspect, the team produced a detailed taxonomy in the form of three separate models, giving a strong base from which to include all key elements from this perspective for the design of workspaces. From the 'people' point of view, a model covering the key agents in collaborative work processes was produced. This gives a fundamental base for taking into account the key dimensions of a workplace from the point of view of human collaboration. As for 'process', two models were developed, one covering the relationship between technology and workplace functionality, and the other the role of specific organizational mechanisms in introducing technology in work processes. These provide a set of guidelines on the key elements that need to be considered when introducing technology in the workplace.

The integrating framework

SANE attempted to integrate the results of the three approaches into a single model to enable workplace design, but this was inconclusive and further serious research effort is required to achieve this objective. Thus, even though SANE achieved its main goal of designing a broad framework for workplace design in terms of the models generated from the three perspectives, it was not possible to go on to the highly desirable further objective of integrating the various perspectives in an overall integrated framework for workplace design.

Project results

Even though in a large research project such as SANE a vast number of issues are studied and a wealth of useful results produced, not everything can be described in an article of this nature.

The project resulted in three validated models for place, people, and process, and an attempt at a unified framework encompassing them. More than 20 deliverables were produced for the EC in the form of reports, most of them intermediate deliverables that contributed to work in progress.

The key deliverables from the project include the final reports on the three frameworks from the people, process, and place perspectives - ie the 'human environment model', the 'technology interface specification', and the 'space environment model' - a 'technology survey' and 'framework validation' report. Arup had inputs into all these key deliverables and was the author of the last.

Tomorrow's office

The key objective of SANE was to develop a 'unified framework' for the design of tomorrow's workplace, and the results achieved have been groundbreaking and useful. The place, people and process models developed were innovative and recognized by independent evaluators of work in the project as a step in the right direction - forming, as it were, the sign of the birth pangs of interdisciplinary participation in workplace design. Individual partners in the SANE consortium have embarked on their own individual plans to take the results of the project forward. Some, including Arup, have jointly proposed a new project (IFORCE) to carry forward into the Sixth Framework the momentum on the study of new ways of working realized in the SANE project. The partnerships and synergies initiated in the project augur well for the future of work and workers in Europe.

Reference

(1) Fernando, T. BRICC. *The Arup Journal*, 30(3), pp22-23, 3/1995.

Credits

Client:
European Commission

SANE consortium partners:
Arup Michael Andrews,
Helen Crosby, Tom Fernando,
Jim Read, Lorna Walker,
Jacqui Webber
DEGW plc
Royal Holloway
University of London
Institut Cerda
IAT
FAW
Telenor AS

Illustrations:
1-13: Emine Tolga
14: Sheppard Robson

Singita Lebombo

Alistair Avern-Taplin Linda Ness

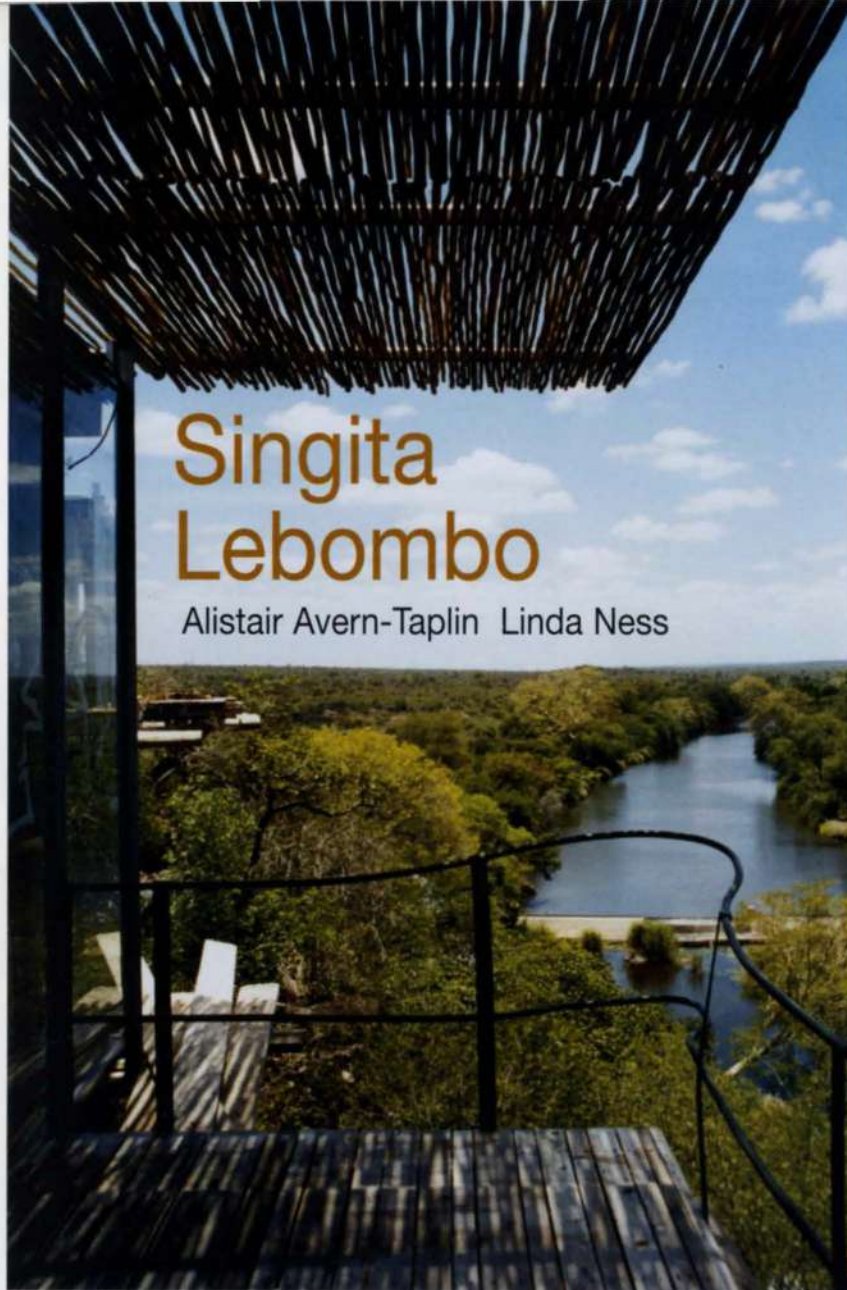

Introduction

Established in 1898, Kruger National Park covers nearly 2Mha on South Africa's eastern borders. It is acclaimed for the diversity of its wildlife and best known as home to the 'Big Five' - lion, elephant, leopard, buffalo, and rhino. Singita Lebombo, the Park's new exclusive R24M bush lodge, is aimed at the very top end of the international tourist market. It offers a world-class safari experience, and has already achieved international acclaim with awards such as the Tatler 101 Best Hotels of the Year Award, 2003.

For its location Singita carefully selected the 20-year N'wanetsi Concession (Fig 2), 150 000ha of previously inaccessible parkland on a long, elevated site in the Lebombo mountain range, focused along a cliff at the confluence of the N'wanetsi and Sweni Rivers. These are uniquely vital to environmental research, the N'wanetsi (Fig 1) being one of the few remaining waterways with a completely undisturbed catchment. A weir nearby is monitored by the National Water Affairs Department, contributing to understanding of global warming and weather patterns.

For most of the year these rivers flow sedately, rich in wildlife and flora, but significant rainfall and flooding occasionally occur. As a result, the 50-year and 100-year flood lines were critical construction boundaries for the lodge development: the 20-year concession window in no way validated the statistical risk of foreign material being washed through pristine environment.

The 20-year life of the structures also involved the Parks Board stipulation that they had to be completely dismantled at the end of that period. This, with the need for robustness and the challenges presented in creating luxury for guests amidst African nature, without destroying to create, challenged engineering thinking and led to new and inspiring ideas.

From the outset, the professions were wholly integrated. Environmental sensitivity instilled a project goal with pervasive clarity at every stage, and united the team. The project philosophy - to 'touch the earth lightly' - became a key theme from foundations through to interior décor.

1. View from a unit looking up the N'wanetsi River.



2. Lebombo Concession within Kruger National Park.



3. Singita Lebombo: completed bush lodge units from the river.



Lodge arrangement

Singita Lebombo is divided into two distinct areas (Fig 4). The larger Lebombo Lodge comprises the main reception, lounge, and dining room buildings, plus administration, kitchens, and workshops. Around this are scattered 15 individual accommodation units along the ridge overlooking the N'wanetsi. The smaller Sweni Lodge is about 1km away, lower down along the bank of the Sweni. This more integrated lounge and dining room building, with skeleton administration and kitchen facilities, forms the nucleus for six more individual units along the Sweni River bank.

The lodge's operation thus covers both nuclei servicing 21 units, but also allows Sweni Lodge to function as a completely separate and discrete six-unit lodge for private guest parties, with operations like catering and event co-ordination remaining centred at the primary lodge.

On plan, the Lebombo Lodge buildings are laid out like an African Medusa, with the central dining room, lounge and outdoor lifestyle area presiding on high ground above the rivers, and floating timber walkways snaking out towards the riverside cliffs and the 15 units. Each is carefully laid out to remain private from the next, but floor-to-ceiling sliding glass panels open to draw in the African bush sounds. This layout necessitated a wide range of structural settings; from units built off near-vertical volcanic rhyolite rock faces to others founded on residual river soils below the tree-line canopy. Services runs are hidden under the walkways. The administration areas are more conventional brick and timber structures quietly separated from the client spaces, but nonetheless maintain the development's overall character into the employees' workspace.

Sweni Lodge and its units reflect the structural arrangements for the primary lodge buildings, while an independent aesthetic supplied the interior design.



5. Interior of a cliff unit.

6. Structural frame of a typical unit.



Touching the earth lightly

The attachment of the timber columns to ground became a focal point in the design development. A steel plate unit was designed to enable the poles to be set up off the ground, with a single bolt pin detail allowing the fin plate connected to the column to be pivoted to suit the angle of the rock surface, and designed to suit the full range of angles anticipated once the unit sites had been chosen. Geotechnical investigation led to a rock bolt detail with threaded steel bars drilled and epoxied 700mm into the rock, and the base plate unit set level side-to-side but front-to-back to the rock angle (Fig 6). This minimized concrete work in this pristine environment, as well as simplifying column erection.

Two further areas are communal to both lodges.

A gymnasium and spa, with exclusive boutique and African curio shops have been built on the site of existing Parks Board accommodation spaces to form a focal point, whilst a 'Boma' has been created at the highest point. This open-air dining area allows guests to gather in the evenings around a central fire, eat, and be entertained by traditional African dancing, instrumental and choral presentations.

Design process

The design team was spread countrywide. This, and the remoteness of the site to normal electronic communications, necessitated site meetings that brought the whole team, with the client, here for two days at a time.

Design development involved scrambling through virgin bush assessing each location, setting out structures, and evolving a theme of construction details that could be universally implemented, to both maintain the aesthetic and ensure that remote construction could continue uninterrupted. Evenings discussing the project around the construction campfire brought the team together, highlighting a sense of purpose beyond construction.

Arup was quick to respond to this design process. To enable ongoing detail development, all specifications and structural details were captured on detailed hand sketches, enabling day-to-day changes to be incorporated into structural construction details that could be faxed to site for immediate implementation as the programme required.

The structures

The generic structure is an unlikely symbiosis of timber and glass, mediated by steel interfaces, with timber panel floors that float above the ground. Tall columns and a conspicuous lack of visible bracing above floor level gives maximum visual exposure to a bush landscape that changes from a sparse twiggy brown to lush leafy green with the seasons. Wafer-thin roof structures are sheathed above and below with organic 'latte' skins that gently fold down to form sunscreens. These structures exhibit a sense of minimalism and simple 'bareness' that is carried through from the architecture to the interior design. They present a sympathetic face to the surrounding bush, which less than six months after completion completely regenerated at the margins of construction.

Accommodation units

The structure of these units (Fig 5) set the precedent for the balance of the structures at the lodge. Each unit presented new challenges for support, and a generic system of details was developed for this purpose. Each has its frontage overlooking the river, with a shaded balcony extending off that elevation (see Fig 3).

The skeleton of each unit comprises six hardwood eucalyptus saligna columns set in pairs across the footprint, running continuously through the floor construction to support the roof.

A saligna pole rafter grillage supports pine beams and saligna floorboards. Above the floor level the poles are square cut, supporting pine rafters, purlins, and profiled, arched-steel sheeting draining into the composite steel gutters that ring the roof.

A full-height façade system of steel-rib mullions supporting prefabricated glass panels runs around the entire perimeter, free of the columns and supported at gutter and floor levels. The front façade units are the full-height sliding panels opening out to the balcony, or a railed opening.

The glazed bathroom unit and outdoor shower are protected from view by a thatched wall set away from the unit, but suspended from it on tubular steel ribs.

A series of curved tube ribs span over the roof sheeting, cantilevering as a fringe over the eaves and connected by steel collars to the composite steel gutter section.



7. Lebombo lounge.

These ribs support the timber shading 'latte', and an air circulation gap above the sheeting. They also soften the visual impact of the roofs from buildings above, like a cocoon. Timber 'latte' ceilings hide the services in the roof space, and rails set into this layer allow a system of curtains to separate areas within the open plan unit.

The structure is braced with diagonal saligna poles below floor level, whilst above, transparency is maintained by confining bracing to the back solid timber walls defined by the architecture, and a single laminated timber 'K' brace on one side elevation.

Most units are set against a rock cliff face, comprising partially fractured granites. At worst the rock slopes away at 60 degrees, and the basic six-pole column set-out meant that the front column heights in places exceeded 9m. Each unit was considered for an optimum bracing arrangement, which below the floor was arranged to avoid the services.



8. The lounge from across the pool.

'We are absolutely delighted. It has set new standards in environmental engineering, and we would definitely work with Arup again.'

*Mark Whitney,
Singita Group
General Manager*



9. Lebombo dining room at night.

Lounge and dining room

All the main building structures (Figs 7-9) follow the same composition theme as the units. Where the vertical span of the columns was excessive, square-cut poles were used in a composite 'triad' arrangement, either together or splayed. Where the columns could not be attached directly onto rock surfaces, small concrete bases were constructed at a suitable level in the overlying colluvial soils, and clad with rock selected from the road construction.

Suspended floors eliminated the need for earthworks operations to form platforms, and the natural ground line was largely left untouched. This approach was used throughout the development. The suspended floors comprise a grillage of saligna pole rafters supporting pine rafters and saligna floorboards.

The roof structures are a composite system of simple steel beam section rafters and edge rails, with pine rafters supporting profiled steel sheeting and insulation layers.

Construction materials

- All timber was sourced from local plantations in the Mpumalanga region, with the saligna poles tested to assess their strength.
- Steelwork was rationalized to a limited series of hot-rolled sections, bulk ordered to ensure that raw materials were primed and stockpiled on the site. Site fabrication from these, plus plate work, was carried out from the construction sketches at the site. A series of generic connection details enabled some improvisation for construction tolerances without any loss of structural integrity.
- Rocks were sourced from cuts during construction of the concession roads and stockpiled for use in cladding plinths and walls.



10. Natural materials in the gymnasium.

The structures are braced above floor level by diagonal bracing in the rafter plane that connects to concrete or brick vertical bracing structures. In the lounge, the latter are tall brick chimneys built as 'organic' enclosures varying in section up their height, whilst in the dining room the bracing elements cantilever vertically off shutter columns.

Below the floor structure, saligna pole diagonal bracing is tied to the column bases, minimizing the number of attachments to earth. Retaining walls were constructed off simple footings, with a core of concrete bricks clad with selected site rock.

The compacted earth wall

The guest experience begins along a floating timber walkway towards the Lebombo reception and lounge areas. On the downside are open views of bush land and the rock kopjes of the far riverbanks, whilst along the upside towers a 5m high, compacted earth wall, its surface roughened and layered with horizontal, undulating waves of earth colours. The face gently rakes back with height (Fig 11).

The architectural concept for the wall was as a backdrop for the entrance symbolizing an ancient riverbank or cliff. With little precedent for this kind of construction in South Africa, Arup drew for a performance specification on in-house experience with compacted earth walls, and several sample constructions using local soils were initiated on site to find suitable strengths and finish.

The wall as built is a composite construction using sand layering with varying cement contents. More cement was used at the base and top of the wall where weathering will be most severe.

With the contractor a construction method was agreed which gave the thick wall, 450mm wide at the base, a core mesh of reinforcement. A shutter system was devised allowing progressive vertical construction, and flat steel compactor units purpose-fabricated for use with hand-held hammer drills that gave the required soil layer work compaction.

As the outer face finish was the key aesthetic feature, the required striated effect was trialled using sands with added organic colouring, but in the end the variation in cement content gave the subtle colour differences. Layers of soils with larger pebbles carefully packed against the outer face shutter were alternated with layers of finer sands. This resulted in a finish that, when brushed down with brooms, presented undulating colour layers: a relief emulating a unique weathered, sedimentary construction.

Construction of the wall took over six weeks.

As the finished product would only be revealed when the fully-shuttered face was deconstructed, continuity in the layering was imperative, and thus the contractor dedicated a team of workers to familiarize themselves with the method and carry the wall through to completion.

The product

The contractor was experienced at building in remote areas, and took on board the environmental issues and requirements for this site. Construction methods invariably observed the design details, and the Arup team developed a good relationship with the site managers to ensure that this was carried through.

Environment considerations continue to touch all aspects of the Lodges' operation. Sewage is collected and biologically digested, finally filtering through constantly monitored reed beds. Water is pumped from on-site boreholes and purified, minimizing consumption. Two 500KVa generators, behind deep earth berms to mask the sound, supply power.

Singita Lebombo was unusual in its progress. Rather than a two-year line of design from concept to construction, the period was more a parallel process of architectural development, structural design, interior design, construction, and outfitting. The result of this sustained process is a magnificent, exclusive lodge location that since opening in early 2003 has lived up to the expectations of worldwide visitors. The development has provided employment for local people, and contributes to national conservation issues and to the surrounding local communities.

Credits

Client:
Langita Market (Pty) Ltd

Architect:
OMM Design Workshop cc

Structural engineer:
Arup (Pty) Ltd
Alistair Avern-Taplin,
Adrian Campbell, Trevor Chetty,
Shaun Dixon, Kim Leach,
Linda Ness

Project manager:
Cyber Projects (Pty) Ltd

Mechanical engineer:
Langford Associates

Electrical engineer:
WSP Consulting Engineers

Geotechnical engineer:
Drennan Maude
and Partners

Environmental consultant:
Environbiz Africa

Main contractor:
Krombou Konstruksie

Quantity surveyor:
Edwin Giesteira Consulting

Interior designer:
Cecile and Boyd cc

Illustrations:
2, 4: Daniel Blackhall
1, 3, 5 -11: Linda Ness

11. The completed compacted earth wall.



