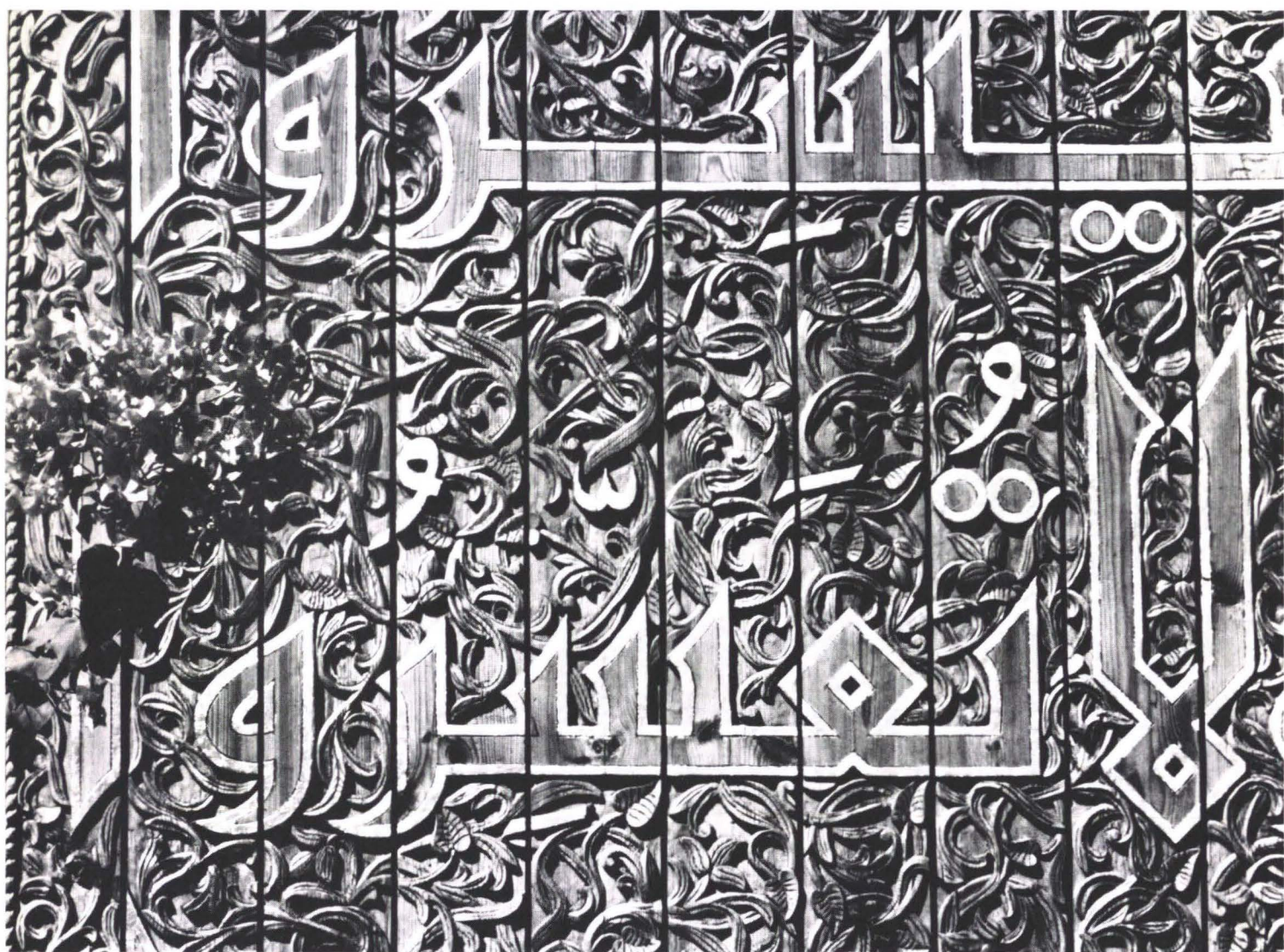


# THE ARUP JOURNAL

DECEMBER 1980



# THE ARUP JOURNAL

Vol. 15 No. 4 December 1980  
Published by  
Ove Arup Partnership  
13 Fitzroy Street, London W1P 6BQ

Editor: Peter Hoggett  
Art Editor: Desmond Wyeth FSIAD  
Assistant Editor: David Brown

## Contents

The consulting engineer in Saudi Arabia, by R. Pearson	2
The spire of Holy Trinity Church Coventry, by P. Beckmann and J. Blanchard	6
Study for a deep water testing tank, by J. Tyrrell	15
A computer system for building services design, by R. Aish	17
Ebury Street Development, by M. Smith	24
Structural Steel Design Awards 1980	26

Front cover: Wood carving, Mecca Hotel (Photo: Rolf Gutbrod)  
Back cover: Riyadh conference centre (Photo: Henk Snoek)

## The consulting engineer in Saudi Arabia

Robert Pearson

The scene in Saudi Arabia changes almost daily as a consequence of the unprecedented building progress which is being maintained. As an example of this progress, only four years ago an open storm drain coursed the centre of Shawa Batha, the main street in Riyadh; the pavements and roads were poorly surfaced; car parking facilities were totally inadequate; public transport was virtually non-existent; there were few major buildings of high quality, etc. Now a visitor to Riyadh can travel via public transport along well-developed streets, seeing many impressive and well-designed commercial or government buildings.

This article tries to give an insight into the challenge facing the consulting engineer working in Saudi Arabia, and highlights some of the differences in practising there and practising in the United Kingdom. Ove Arup and Partners established a small local design office in Riyadh in 1975 shortly after the construction of their first two major structural design projects in the Kingdom. These projects were the Riyadh Intercontinental Hotel and King Faisal Conference Centre, for which Arups were the structural engineers to the architect Trevor Dannatt; and the Mecca Hotel and Conference Centre for which the architects were Rolf Gutbrod and Frei Otto.

During the last few years the office has expanded significantly for structural work, multi-disciplinary work, and specifically for the detailed design of two very large projects, namely; 650 km of modern dual three-lane 2 expressway for the Ministry of Communica-

tions; and a new government project in Riyadh. The latter consists of three major buildings, King's Office, Council of Ministers and Majlis Al Shura, with an estimated construction cost of £520m. The client is the Minister of Finance and National Economy.

Before discussing consulting engineering in Saudi Arabia it is relevant to briefly outline the present building developments in the Kingdom. The Government has just entered its third five-year plan. The previous five-year plans were primarily directed towards improving all aspects of communication and travel, education, hospitals and housing. The present five-year plan gives much greater emphasis to industrial developments, including agriculture, so that in the future the Kingdom will not rely primarily on oil exports for its income. This can be seen in the vast developments now proceeding in both Jubail and Yanbu. Therefore, for the consulting engineer there is a noticeable shift from the design of separate buildings to the design of industrially-related projects. One could say that this presents a more challenging environment for the consulting engineer because some of the Government projects now being let consist of large community developments with a miscellany of different buildings.

The difference between Saudi and UK practice can best be illustrated by looking at the following aspects individually:

- (1) Construction
- (2) Design programme schedules and fees
- (3) Local design
- (4) Examples of projects recently completed.

### Construction

Up to approximately five years ago, almost all major buildings constructed in Saudi Arabia had a reinforced concrete structural frame. More recently, a significant number of steel-framed buildings have been constructed, steel being used for the purpose of shortening the construction period. Because all rolled steel

sections are imported, the time to get the steel to the site usually dictates that the design of these buildings is part of a design-and-construct package.

At present however the emphasis is swinging back to reinforced concrete for two reasons. Government clients are insisting that, where possible, indigenous materials and products are to be used. This applies even if use of the local material or product has some cost penalty. Secondly, contractors are demonstrating that record construction schedules acceptable to the client can be achieved using conventional reinforced concrete buildings, where possible making use of precast concrete elements which are now readily available.

When considering which materials, finishes, etc. to employ, the designer can assume that almost everything is available in, or can be readily imported to, Saudi Arabia. There are many precast concrete manufacturers and ready-mixed concrete plants; mesh reinforcement is assembled in Jeddah; clay hollow blocks can be obtained as against the traditional dense hollow concrete block; an increasing stock of rolled steel sections is available in Jeddah; aluminium alloy window and door frames are made locally; air-conditioning units are assembled in the Kingdom, etc.

The construction programme schedules achieved in Saudi Arabia are remarkable, especially so because these construction schedules are, on the whole, being accomplished without a loss in the quality of the project. Generally, the construction period is about 60% of what it would be in England, with the construction costs in the two countries now being virtually the same. Contractors from the Far East still continue to produce tender prices 20% lower than other contractors. Hence the competition is very fierce.

As examples of the speed of construction, the Sitten Street apartment and offices complex

in Riyadh for the General Organization of Social Insurance (37,000 m<sup>2</sup> gross area) was completed in 24 months. A comparable building in size and complexity, e.g. the Wolverhampton Civic Centre, took 34 months to construct. Alternatively, the new Lloyd's Redevelopment building in London is currently estimated to take 5½ years to construct; in Saudi Arabia it would take 3-3½ years. The climate in Saudi Arabia results in virtually no construction days being lost due to inclement weather, but for three months of the year site personnel have to work in shade temperatures which are in excess of 40°C (104°F).

To meet the construction programmes many contractors work 16-18 hours per day, seven days a week. Furthermore many of the labour force from the Far East are on one-year bachelor status contracts with no holiday allowance. As a consequence a percentage of the labour force is always absent due to exhaustion.

### Design programme schedules and fees

For the Saudi Government to achieve the objectives of the current five-year plan, the construction programmes have to be very short. It follows that the time for the design must also be the minimum possible, particularly as a design-and-construct package can often produce a building quicker than the more conventional appointment of consulting engineer separate from the appointment of the contractor. Whether the design of a building is as good using the design-and-construct route is questionable. Certainly this approach gives the client less opportunity for contributing his own ideas and requirements during the design development stages.

Typically, a 35,000 m<sup>2</sup> commercial building will be designed in a maximum of 9-10 months, this time including say two approval periods of two weeks each after the sketch design and design development stages respectively. In addition, at the start of the design programme the consultant has to carry out a topographical site survey and geo-technical site investigation, as well as confirm all the services available around the site. Often no services drawings are available from the local utility authorities and one has to check with other consultants who, for example, may be designing new drainage for the area; and then the local authorities have to approve the services demands for the site. In a recent large project designed by Arup Associates, the sewage effluent has had to be piped into a storage tank on the site and pumped out at regular intervals until such time that adequate new main drainage is constructed. Such aspects make it that much more difficult to complete the design on time, and if one is late the client can impose the standard penalty clause of 1, 2, 3 and 4% (up to a cumulative maximum of 10%) deduction of the fee for the first, second, third and fourth months delay respectively.

In calculating the fees required for a project many things need to be considered; the cash flow, the type of job, the timescale, the client, etc. As in contracting, the competition for design work is very fierce and there is always another consultant willing to take the job at a lower fee. The Saudi tender regulations require not less than five in number to be invited for Government projects and this applies to both consulting and contracting.

Many of our potential clients undertook their training in the United States where consultants produce much less detail than in the United Kingdom, and more of the 'shop-drawing' (e.g. detailed pipe-run layouts, detailed reinforcement drawings, etc.) is left to the contractor. It is difficult to convince such a client that by preparing more detailed information (and therefore requiring a higher fee) the contractor's tender price can be reduced significantly, because with more

information to work with the contractor's tender can be more accurate. A recent example of this was a large prestigious Government project where contractors were asked to tender in an eight-week period and the consultants had not prepared a bill of quantities.

Therefore, what fees can one expect to receive?

As Saudi Arabia develops, one would hope for a quasi scale of professional fees. In the meantime, however, bearing in mind that the building costs in Saudi Arabia are almost the same as in the UK, the maximum fee one can expect is about 5-8% of the building cost; and to get this fee one will be fortunate. Normally it will be between 2-5% and projects will be let for much less. The important aspect is that the level of design service provided to the client, compared to the service provided in the UK, is dramatically reduced; more is said about this later. Not long ago the complete design for all disciplines of a university project costing over 1 billion Saudi Riyals was given to a consultant for a fee equal to 0.6% of the expected building cost. It is possible that, for this project, the consultant was subsidized by his own government! In addition to competing with such low fees one also has to absorb the rising value of sterling against the Saudi Riyal. Four years ago £1 = SR5.75, now £1 = SR8.0.

The toughest part of fee negotiations is the bargaining. Trading and therefore bargaining is hereditary to Saudis and they are much better at it than we are. They are also extremely shrewd in dealing with people. It seems that one is not expected to ask for the minimum design fee needed at the start of discussions – bargaining is a time-honoured custom and one should be prepared to negotiate the fee from the original proposal. The only strength a consultant has in such negotiations is to be able to walk away from the project – but that is also the Achilles heel: if one does walk away there is a queue of consultants willing to do the project at lower fees.

Obtaining payment of fees can be a problem. In the UK when an invoice is submitted to a client, the fees are usually paid automatically after a relatively short period of time, whereas in Saudi Arabia invoices are sometimes temporarily ignored. One has to be prepared to make several personal visits to the client to obtain payment; being sure to observe the customs when meeting clients, i.e. not to walk in immediately asking for money but be prepared to discuss the job and any other matters until it is appropriate to mention fees.

### Local design

The biggest impact on design is from the short design programme and the low fees. Although the design programmes are very short, the final building can nevertheless be of high quality, e.g. The Adil Khashoggi building in the photograph was designed in eight months and constructed in 30 months.

The other major difference from UK practice is that in Saudi Arabia the tender information is also the final construction documents. Hence, the consultant does not prepare tender documents as they are known in the UK.

The number of drawings presented to the client is usually about 1/3 of that prepared in England. The only way one can make a profit for the low fees available is to design the project once only, unlike in the UK where the design may be changed several times and the same drawing produced more than once. The rapid design process is a tremendous stimulus to the engineer. The whole design team, particularly the architects, must be dedicated to this speed of working.

The Saudi tender regulations stipulate that the contractor carries liability for 10 years after the project is completed. For example,

should there be a structural failure because of faulty consultant's design, the contractor, as well as the consultant, is held accountable. An unfortunate corollary of this is that, because of the contractor's liability a less scrupulous consultant could be tempted to provide an inadequate level of design service.

As clients get to know one better, one is able to obtain better fees; but an area of constant concern is the lack of site supervision. Ove Arup & Partners are asked to supervise only about one in four of the projects they design in Saudi Arabia even after trying to demonstrate to clients the benefits of full site supervision. The worry is that, should structural failure occur in a building designed but not supervised by a consultant, his reputation will suffer even if the design is perfect.

In Saudi Arabia one has to obtain 'permission to build' from the local Municipality. There is no separate planning and building regulation approval as in the UK. When commissioned by a Government client, the client usually obtains the building permission approval, but when commissioned by a private client the design team are responsible for getting the approval from the Municipality. This procedure is not straightforward. The Municipalities do have some printed information giving general planning and building regulation conditions but the data is rather sparse; and the Municipality will only give building approval on the final detailed construction drawings. There is usually insufficient time to complete all detailed drawings when the time arrives to submit for building approval. Moreover, if the Municipality request a few changes there is the risk of having to change drawings. Therefore, the practice is to prepare the structural layout drawings, take copy negatives and produce typical reinforcement details which are just enough for submitting to the Municipality. When approval has been granted the detailed reinforcement drawings are prepared. This procedure wastes some copy negatives, and a few days only of drawing. The Municipalities do not often ask to see design calculations and they will accept designs which are to any of the internationally recognized codes and standards.

Rarely are reinforcement bending schedules prepared because the fee does not allow for them. On several occasions, after a structural design is finished, the contractor has separately appointed Ove Arup & Partners to prepare bending schedules. On any large projects the reinforcement detailing is usually sent back to the Arups' London office. This happens on a regular basis and the London reinforcement detailing group now have considerable experience of the level of service to be provided for this type of work.

With experience one soon learns the particular local conditions relevant to the design; a few examples are:

- (1) One is cautious about using load-bearing wall construction because of the risk of removal of a wall at a later date.
- (2) Shops should usually be designed for heavier loading than the UK codes recommend because of the souk (bazaar) tradition of using the shop for the purpose of bulk storage as well as for display.
- (3) Wind, temperature, rainfall and humidity data have only been collected in the last 10-15 years. Originally the airports collected basic climatic data but now thorough records are being obtained by the Ministry of Agriculture. Due to the lack of rainfall records for a sufficient period of time it is accepted, for example by the Ministry of Communications, that one can apply rainfall prediction data from Arizona because the two areas have very similar climates.



**Fig. 1**  
Kocommas model  
(Photo: Büro Gutbrod)

The most stimulating aspect of the design work executed in Saudi Arabia is the speed with which projects pass through the office. The experience the engineer gains is exceptional; he does the design quickly and sees the results equally as quickly. The hours may seem long (a standard working week is 45 hours) but the pace of development is so rapid that most engineers and contractors put in more hours than this.

#### Examples of projects recently completed

The following, together with the photographs, briefly covers four of Arups' projects in the Kingdom.

#### Trans-Arabian expressway

In early 1977 Ove Arup and Partners were appointed by the Ministry of Communications to undertake a reconnaissance study and prepare the design for the dualling of approximately 250 km of existing road to the east and 250 km to the west of Riyadh. The road to the east commenced just outside the city and extended to Hofuf Junction.

Later the scope of work dramatically increased. The project became the design of approximately 650 km of modern dual three-lane highway with grade separation at all interchanges, numerous accommodation bridges (or camel underpasses) wadi bridges and service areas, etc. Also required were by-passes at major villages along the route.

The work entailed aerial surveys, detailed ground surveys, soil sampling and testing for the full length of the road and soft core and rotary boring for 64 bridge, 13 viaduct and 4 underpass sites.

It was necessary to install a computer in Arups' Riyadh office. The machine chosen was a Prime 400, on which was mounted the MOSS design system, used extensively for the highway design, many of the road drawings having been plotted entirely by computer.

The scope of work further increased when the Ministry of Communications asked Arups to design a section of the Khurais road in the eastern outskirts of Riyadh, which involves considerable lengths of viaduct and underpass structures.

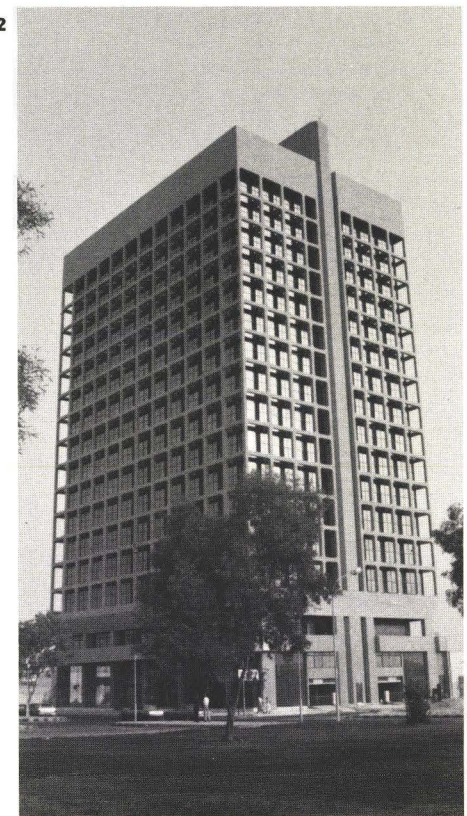
The documentation for the 650 km has been split into contract packages for which tenders have recently been received. Construction is hoped to start as soon as possible. The Khurais road project will be a negotiated contract but again construction is expected to commence very soon.

#### The Government complex, Riyadh

Since late in 1975 Ove Arup & Partners have been working with Professor Rolf Gutbrod and Professor Frei Otto upon the design of a major government centre to be constructed on a site just north of Riyadh. The project is composed of H.M. The King's Office, The Council of Ministers Building, The Majlis Al Shura Assembly Hall and Representatives' offices. Additional development on the site includes a major mosque and the services accommodation required for such a centre.

H.M. The King's Offices building comprises private offices and audience halls for His Majesty The King and His Majesty The Crown Prince, and the supporting administrative offices. The Council of Ministers building includes a council chamber for the ministers and office suites for themselves and their staff. The Majlis Al Shura Building includes an assembly hall for 300 Representatives and their associated offices. The total area of construction is approximately 250,000 m<sup>2</sup>. The office accommodation comprises frame buildings clad with a marble façade which are arranged around the various assembly halls in the project. These are set within interior gardens which are covered by shaded and glazed steel lattice compression domes, the largest of which covers the Majlis Al Shura, and is 92 m in diameter.

**Fig. 2**  
Adil Khashoggi building  
(Photo: Robert Pearson)  
Architects: Basem Shihabi  
and Nabil Fanous, Riyadh





**Figs. 3-6**  
Sequence of rock anchor installations on site for Ministry of PTT Headquarters building (Photos : Robert Pearson)

The contract for the construction of the civil engineering and ancillary accommodation has recently been signed and work started on site. Tenders for the construction of the major part of the works are to be sought in due course.

### The Adil Khashoggi building

This building can be seen to dominate the skyline as one approaches Dhahran airport. The view is particularly dramatic at night when the external structure is silhouetted by the internal lighting. The building, with two levels of basement car parking, is primarily office space with some levels for apartments.

From the design point of view there were two unusual aspects. Firstly, the geotechnical desk study indicated the possibility of solution cavities in the underlying limestone. In the subsequent site investigation, cavities were found about 8 m below foundation level and therefore beneath the foundations a regular grid of drilling and grouting was carried out to seal any cavities. The second aspect was the pouring of the large external concrete corbel above mezzanine level. This corbel is 2.7 m deep and 2.3 m wide at the top. Guidance was given by Arups' R & D Group regarding the possible problems from shrinkage cracking due to the high differential temperature gradient that can occur during the cooling of such a massive concrete section. It was decided to insulate the member thoroughly with quilts for two weeks following the concrete pour to decrease the cooling rate and



**Figs. 7-8**  
GOSI Sitteen Street complex (Photos : Mike Head )



thus minimize temperature differentials. The result was satisfactory. The whole of the external structure was shot-blasted and the uniformity of concrete colour and absence of shrinkage cracks in the corbel speak highly of the Korean contractor who carried out the construction.

### Headquarters building for the Ministry of PTT

Ove Arup & Partners were initially commissioned by the Joint Venture main contractor Saudico/Wolff and Muller to carry out a geotechnical site investigation for the new headquarters building for the Ministry of Posts, Telephones and Telecommunications in Riyadh. The building comprises 115,000 m<sup>2</sup> in area with 63,000 m<sup>2</sup> below ground level as a three level parking zone. The commission was later extended to redesign the foundations, basement slab and retaining walls.

The site investigation showed the water table to be at -8 m and piezometer tests indicated a full hydrostatic head would result from the water table. The site environs are served with main drainage but the building is on the main wadi which passes through the centre of Riyadh. In the wadi catchment area domestic buildings are rapidly being constructed with no drainage planned for about eight years, and the domestic effluent is discharged into septic tanks with soakaways.

Therefore, it was expected that a perched 'sewage' water table could raise the existing water table above the -8 m level. This has happened in other parts of Riyadh. With the basement foundation level at -14m the building was subject to flotation over an area of 2/3 of the site. To resist this flotation the basement slab was rock-anchored into the limestone with 1450 anchors 9 m long.

The design posed conceptual stability problems regarding the appropriate load factors for flotation as the water table varied. It

would have been convenient to take full load factors with the water table at ground level but the construction cost would have been prohibitive. To complicate the situation there was no local data available on the seasonal variation of the water table. The design finally adopted gave reduced load factors should the water table rise to ground level; the design was evaluated and approved by the French checking authority, Socotec. The photographs show the construction sequence for the rock anchors.

### GOSI Sitteen Street complex

The last project is the Sitteen Street office and apartment complex for the General Organization of Social Insurance (GOSI). The total gross area is 37,000 m<sup>2</sup> with one basement of car parking. The two identical blocks are offices and the inclined 'L' block contains apartments. The full detailed structural design was carried out in Arups' Riyadh office over a period of only 5 months.

The geometry of the 'L' block required special provision to ensure lateral stability. Although rock anchors were considered at the time as a means of stabilizing the 'L' block, it was decided instead to provide a continuous counterweight reinforced concrete box (back-filled with sand) along the rear of the block at foundation level. The complex was completed in 24 months by a local Saudi contractor, Saudi Constructioners, and the quality of work is excellent.

In the early construction stages the project was about four months in delay. As a result Arups' Project Planning and Site Services group was commissioned to prepare a detailed work and manpower resource programme using the original contractual completion date. The programme showed it was just possible to complete on time, without lowering building standards, and construction was finished just within schedule - a tremendous achievement for both contractor and supervising consultant's staff. 5

# The spire of Holy Trinity Church Coventry

Poul Beckmann  
John Blanchard

## Introduction

The official guide states: 'The Parish Church of The Holy Trinity was founded soon after the year 1043. In that year Earl Leofric and the Lady Godiva, with the support of Edward the Confessor, founded and endowed the new Benedictine Priory in Coventry. The site of this Priory and the early "Cathedral" of St. Mary is only a few yards to the North of the church, on the other side of Priory Row'.

It is a tradition that Holy Trinity was the Parish Church for the northern half of Coventry, which was owned by the Priory, whilst St. Michael's, adjacent, was the Parish Church for the southern half which came into the ownership of the Earls of Chester. St. Michael's became the Cathedral which was destroyed in enemy air-raids in 1940, whilst Holy Trinity was saved by the efforts of Canon Clitheroe who organized continuous firewatching on the roofs and is credited with having personally shovelled several fire bombs off the roof.

Like the majority of mediaeval churches, Holy Trinity has features of several, successive, architectural styles: the North Porch is Early English, the Chancel and Main Nave are Decorated and the West Window is Perpendicular.

The spire is the second highest of the famous 'Three Spires of Coventry' the spire on the tower of St. Michael's reaches to 92 m, Holy Trinity 72 m and Greyfriars' Church 58 m. The original spire, which was slightly lower, was blown down 'in a terrible gale of wind' on 24 January 1665. The roof of the church was badly damaged by the fall and a boy, passing by at the time, was killed.

The spire was reconstructed in its present shape in 1667.

The lantern of the tower was housing a peal of bells until 1854 when Sir Giles Gilbert Scott, who was restoring the church, had them removed to an adjacent timber belfry. One reason for doing so may have been a wish to bring more light into the central crossing by removing the ringing floor which was situated immediately above the crowns of the tower arches, but an additional, if not the prime, motive may have been anxiety about the integrity of the masonry: the tower, as indeed the whole church, was built of a local, very soft sandstone, which weathers badly; so much so that a major restoration of the tower was carried out about 1916.

Having survived the air raids of the Second World War, largely intact, the church stood without giving cause for concern until 1966, when, prompted by widespread storm damage to roofs in Sheffield, the vicar instructed the architect, Mr C. F. Redgrave, to ask us to examine the stability of the spire.

## The spire

The spire rises 42 m from the top of the central tower. It is of octagonal section in plan and about 6.5 m wide 'over the flats' at the base where the transition to the square section of the tower takes place through so-called squint arches which are visible in the top corners of the one-time bell chamber. The shape of the spire is not a perfect pyramid as the lowest 9 m of the facets taper less than the remainder; (this might indicate that a more ambitious height was originally intended, but no written evidence of this has been

found, so it is also possible that it resulted from an initial setting-out error, corrected at a later stage of the work).

The spire is constructed as a single shell of sandstone masonry, and the few measurements which, in the absence of scaffold or ladders, could be taken at the initial inspection, indicated an overall thickness of masonry of 0.20 m, substantially reduced in places by ornamental carving and weather erosion.

Apart from this, the masonry appeared to be in fair condition: there were only a few minor vertical cracks and there was no indication that the bed joints had opened due to uplift on the windward face.

The most interesting features inside the spire were (a) the vane rod, a 32 mm square wrought iron rod, which, as the name implies, connected the spindle of the weather vane with the central beam in the floor of the bell chamber and (b) a number of 'stars' or 'spiders' of tie rods which at several levels connected the vane rod to the facets (or 'cants' in steeplejack jargon) of the masonry. At the upper levels there were four rods in each 'spider', each hooking round the vane rod; lower down there were eight-legged 'spiders', the central connection being through a split collar, bolted together. At the lowest level the spider rods were connected to a bracing ring of timber which in turn was bolted through the masonry. Apart from, or perhaps because of, a liberal coating of pigeon droppings, the ironwork inside was in fairly good condition.

On the outside, the tie rods terminated in iron anchor plates, bearing on the masonry. These had originally been shrouded in lead, but the anchor plates had nevertheless rusted badly in many places and were pushing the lead covering off. Some small cracks were radiating from some of the anchor plates.

Visually there did not appear to be much to

worry about, but the slenderness of the masonry suggested that the wind stability needed great care in investigation.

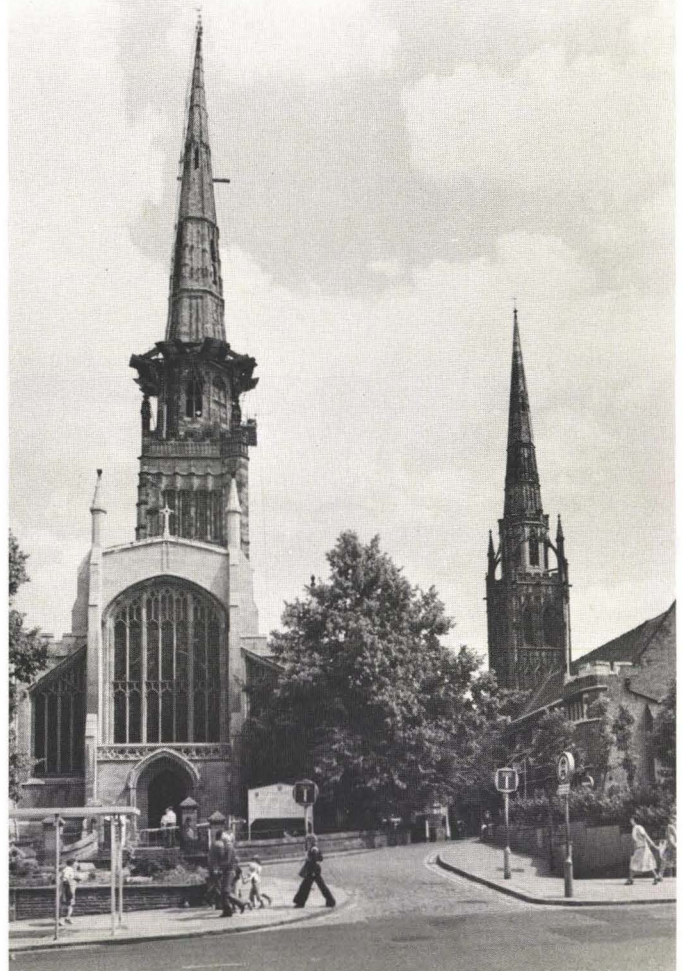
## The wind

This was in the halcyon days before Ronan Point had collapsed and officialdom had tried to bury the Art of Structural Engineering under a mound of circulars and regulations. 'The gospel according to Davenport' of predicting probable wind speeds by statistical analysis of observations was being spread, and results of wind-tunnel tests were being used to improve the translation of wind speeds into wind loads, but the British Standards Institution, whilst admitting that their table of wind loads might be out of date, had not yet published their new code on how fast the wind was allowed to blow at a given point in Britain. We therefore wrote to the Meteorological Office and received the following reply:

'We do not have wind observations at or near a height of 240 ft. for the Coventry area. Wind speeds at the standard height of 33 ft. above the ground corresponding to 90, 95 and 100 m.p.h. at 240 ft. were obtained by assuming a normal variation of speeds with height. The adjusted speeds were analysed statistically in relation to 40 years of records from Birmingham (Edgbaston) from which it has been estimated that the probable return periods of gust speeds (mean over 2-3 seconds) for 90, 95 and 100 mph at 240 ft. above the ground are 35, 57 and 100 years respectively. The return periods for mean 1 minute speeds of 90, 95 and 100 mph at 240 ft. above the ground are so great that for practical purposes it can be assumed that these speeds will not occur.

I hope this information will serve your purposes. An account for £1. 8s. 6d. is enclosed to cover the cost of answering your enquiry'.

**Fig. 1**  
Holy Trinity  
and St. Michael's  
(Photo:  
Poul Beckmann)



### The first check on wind resistance

Our interpretation of the Meteorological Office's letter was that the one minute mean wind speed should be taken as 90 m.p.h. (40.2 m/sec.) at 240 ft. (73 m) height (since this was the lowest wind speed quoted that would not occur) or 64 m.p.h. (28.6 m/sec.) at standard height. Adding 15% 'for luck' gave a design wind speed of 70 m.p.h. (31.3 m/sec.) (compared with the 72 m.p.h. to be assumed for exposed sites near the coast or more than 240 m above sea level). The code of practice, current then, was *CP3 Chapter V: 1952* in which wind speeds were expressed as one minute means at a standard height of 10 m. For our design speed the code gave an average design pressure on the spire of 1.4 kPa or a total wind force of 180 kN acting 14.8 m above the base of the spire.

The critical cross-section was assumed to be through the windows at the base of the spire. Taking the thickness of the masonry as 180 mm (7 in.), the total weight of the spire above this level was 1750 kN. Normal elastic stress calculations then showed that, under the design wind, the windward bedding joints would not open and the leeward compressive stress in the stonework would be 1.4 MPa (200 lb./in.<sup>2</sup>) which was acceptable for good sandstone. Even if the thickness of the stone were to be reduced to 150 mm (6 in.), which we thought might take at least another 100 years, only the extreme windward bedding joints would open.

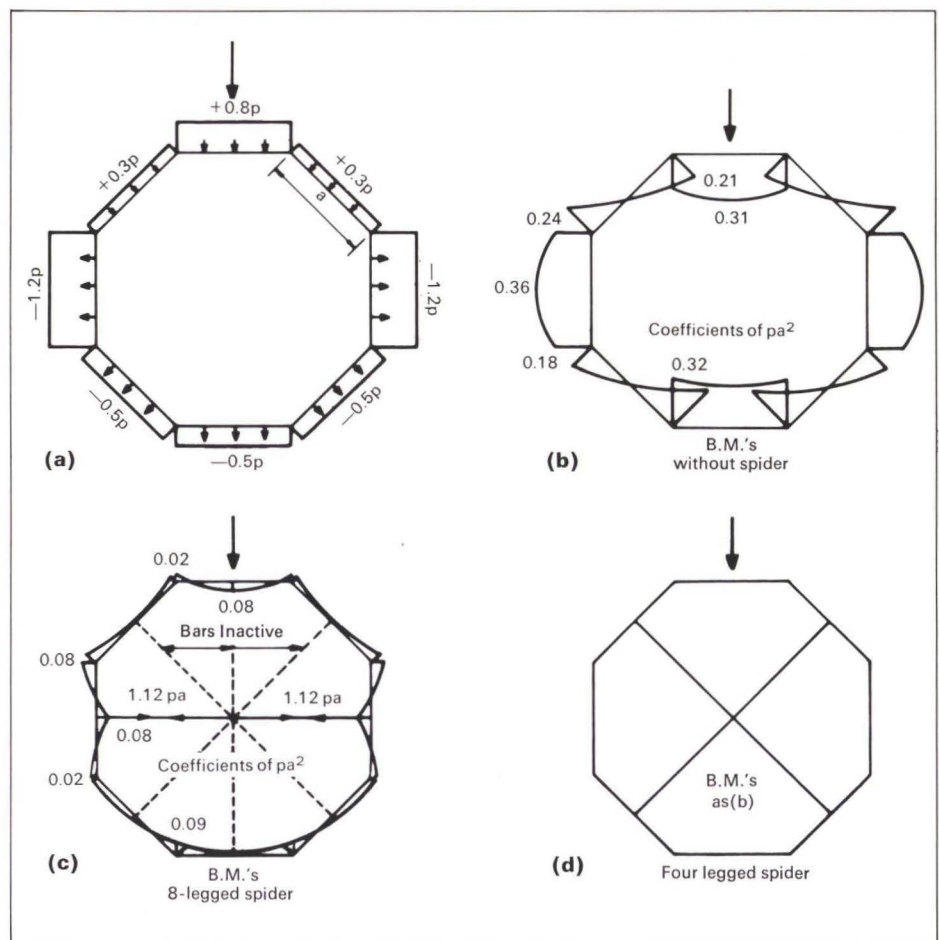
To make sure, an ultimate load check was also made (this was after the Ferrybridge collapse but we would like to think that we would have realized the need anyway), assuming that failure would occur when the windward crack extended halfway across the spire and the compressive stresses would be increasing sharply.

Even with 150 mm walls the wind speed to cause failure, so defined, was 83 m.p.h. (37.1 m/sec.) at standard height or 116 m.p.h. (51.9 m/sec.) at 240 ft. (73 m). Again referring to the Meteorological Office's letter this wind speed was so unlikely, even for two/three second gusts (as opposed to the one-minute mean speeds on which the then current code was based), that the overall stability of the spire was pronounced to be satisfactory. Even if the failure wind speed had been more likely to occur we would most likely not have been concerned. We would have used the argument that such a short gust would not overcome the inertia of the spire and overturn it. Subsequent calculations indicate that this argument is specious; gusts of only a few seconds would suffice, if strong enough, to topple the spire and would certainly cause serious damage in the compression zone. However, the argument that such short gusts do not act simultaneously over the whole spire is valid, but this was not understood at the time.

### Arachnida

The next item was to check whether the rather thin walls of the spire were strong enough to resist the local bending due to the wind pressure. In addition to the bending moments arising from simple spanning between corners, those due to the non-uniform wind pressure which cause a change of shape of the octagon (analogous to ovaling moments in circular chimneys) had to be considered. In particular, we wanted to know whether the tie-rod spiders played an important part in resisting these local effects, in which case any deterioration in their anchorages would have to be viewed with concern.

Fig. 2 (a) shows the assumed pressure distribution around the octagon, chosen so as to give the, at that time, correct drag factor of unity; 'p' is the basic stagnation pressure at that height, 'a' is the length of



**Fig. 2** Effect of spider on wind-induced bending moments in spire walls

the side of the octagon. (b) shows the resulting bending moments per unit height of wall in the absence of any spiders. (c) shows the bending moments when a spider is provided with a leg at the centre of each face. The legs of the spider are assumed to resist tension only, so that, with the given wind direction, six of the legs become inactive. It is interesting to note that if they had been capable of carrying compressive loads the peak value of bending moment would have been virtually unchanged. Also, rather surprisingly, allowance for the extension of the active tie had a negligible effect on the bending moments.

The spiders reduce the peak bending moments in the wall to  $\frac{1}{4}$  of their original value. This reduction is highly significant; near the base of the spire the maximum bending stress in a 180 mm wall without spiders would be about 0.5 MPa. This is uncomfortably high for a working stress where the effect of openings has not been considered. The corresponding stress of 0.13 MPa when spiders are provided is, however, instantly acceptable.

The spacing of the spiders was generally 3 m. Near the base of the spire this was about  $2\frac{1}{2}$  times the width of the side of the octagon so that it did not seem unreasonable to assume that the spiders effectively restrained the change of shape even at sections midway between the spiders. However it was doubtful whether the bending effect of the tie force applied at midspan would be completely spread. The local bending moment in the wall at the tie rod was therefore likely to be somewhat greater than shown in Fig. 2 (c). The maximum tension in a tie rod was calculated to be less than 10 kN so that, even if the cross-section of wrought-iron rod were reduced by corrosion to 20 mm square, the resulting stress would be quite safe.

It can be seen from Fig. 2 (b) that most of

the bending is caused by ovaling, so that the tie rods are just as effective if they are attached near the corners instead of at midspan. (This was the detail preferred for practical reasons when the spiders were later replaced; it has the advantage that local bending stresses at the tie-rod are reduced).

With the eight-legged spiders it is immaterial if the wind is not blowing along a leg as conveniently assumed in Fig. 2 (c). However with the four-legged spider this is not true. The actions of the two types of spider are identical if the wind is blowing parallel to a leg but with the wind blowing at 45° to the legs of a four-legged spider, as in Fig. 2 (d), all the legs are inactive. This was presumably why the four-legged spiders in the spire were alternately rotated through 45° on plan so that at least every other spider was effective whatever the direction of the wind.

Whether or not our forefathers had thought about it in those terms, we felt justified in giving the spire a clean bill of health, subject to periodic inspections, particularly of the anchorages of the tie rods and this was the conclusion of our report which we submitted to Mr Redgrave in April 1967.

### Campanological interlude

Having thus been reassured about the immediate safety of the tower, the vicar and the churchwardens turned their thoughts to the bells which since the 1850s had hung in a rather stark-looking and, by now somewhat dilapidated, timber gallows adjacent to the church.

The question which was put to us was: As the tower had been restored in 1910, and as the spire, according to our report, had an adequate resistance to wind forces, could the bells be re-installed in the tower and would it be safe to ring them in the proper English fashion?

To be able to answer this, we had to study the forces which might be imposed on the tower if the bells were rung.

The assessment of the structural effects of bell-ringing provides one of the more satisfactory uses of dynamic analysis because, when the engineer believes his answers, he may be deluding himself less seriously than in other applications. Loading from bells is, in practice, deterministic so that there is no need to resort to the dubious statistics of wind and earthquake loading. Loading from machinery is also deterministic but who would believe the values of out-of-balance loads given on machine drawings, even if he knew what the draughtsman had intended them to represent? It is true that bells are often supported on masonry structures whose dimensions and physical properties are imperfectly known, but the accuracy with which modern formed structures are described is probably largely illusory. At least a church tower can normally be modelled as a simple cantilever, perhaps with different shear stiffness where it passes through the nave, so that it is easy to visualize the effect of different tower properties within credible bounds.

To understand how bell forces are determined and combined, it is necessary to understand something of the mechanics of bell-ringing. There are five ways of producing sound from a bell. In 'clocking', a rope is tied to the clapper which is pulled against the side of the stationary bell. A bell is 'chimed' by hitting the soundbow (the reinforced rim) with a hammer controlled by a rope. Chiming is also used to describe the technique of swinging the bell slightly and checking it so that the clapper travels on and strikes the bell. If the chiming is in slow time it is known as 'tolling'. Finally, in 'ringing', the bell is swung through a complete circle from mouth upwards to mouth upwards.

Although clocking the bell is the easiest method it has, apparently, the disadvantage that eventually it will crack the bell. The churchwardens of St. Lawrence's, Reading, resolved in 1594: 'Whereas there was through the slothfulness of ye sexton in times past a kind of tolling ye bell by ye clapper rope; it was now forbidden and taken away and that the bell should be tolled as in times past and not in any such idle sort.'

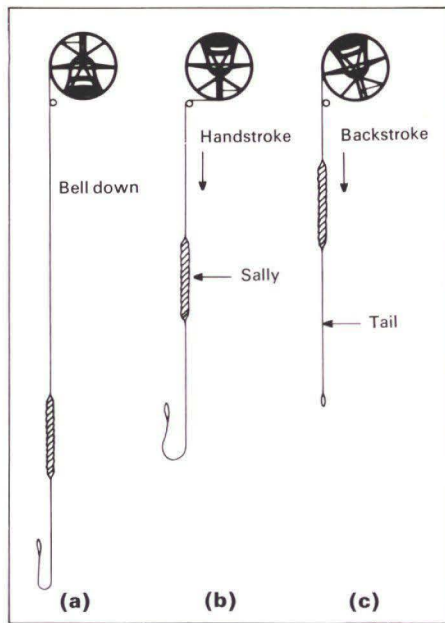
It is not clear whether the churchwardens were more concerned with the lack of moral fibre in the parish or with the possible expense of replacing the bells, but in fairness to the ringers it should be said that, at that date, the bells would probably have been poorly balanced and hence required considerable effort to swing even though the swing would have been limited, possibly to a half-circle. It took 24 men to ring the largest bell at Canterbury but they were probably using a treading-board attached, like a see-saw, to the headstock of the bell.

### Chiming

Chiming the bells with hammers is the most suitable method for producing harmonious compositions and is that favoured on the continent of Europe.

In ringing through a complete circle the clapper hits the bell with the greatest force, producing the fullest and most far-reaching tone. This is the method generally favoured by English speaking people and used only by them. It is also the only method which produces significant dynamic loads and thereby interest to the structural engineer. (He may however wish to recommend the other methods to a harassed vicar when his prognosis of the effects of full bell ringing is unfavourable!)

The bell normally hangs, of course, mouth downwards (Fig. 3a) and cannot be swung in a full circle from this position. Before



**Fig. 3**  
Bell, wheel, rope and sally

ringing, therefore, the bell has to be 'rung up' by carefully timed increasing swings, and then set mouth upwards as in Fig. 3b (actually slightly past the point of balance and against a back-stop). Pulling on the 'sally', i.e. the 'handstroke', will then rotate the bell from  $\theta=0$  to  $360^\circ$  (Fig. 3). From there a pull on the tail of the rope, i.e. the backstroke will rotate it from  $\theta=360^\circ$  to  $0$ , back to its set position. The complete swing, go-and-return, or handstroke and backstroke, takes four to five seconds. It should be noted that ringers may set their bells and leave them temporarily unattended. It is unwise to enter the belfry at such times. The engineer, not having read Ref. 2 may be walking along the narrow bell-frame and extend his hand to gain support from a bell which would be too finely balanced to provide it!

### Improving balance

The invention of the whole wheel in the 16th century and improved balancing of the bells enabled the ringers to exercise finer control of their timing. As this was slowly appreciated, ringing became more sophisticated, progressing from 'rounds' to 'changes'. In rounds, the bells are rung repeatedly in the same descending sequence, treble to tenor. In changes, the sequence is changed at each stroke according to the following rules:

The first sequence is rounds; the sequence must change at each stroke; any bell may 'hunt' (change its place up or down in the sequence) not more than one place at a time; no bell may occupy the same place in the sequence for more than two consecutive strokes.

The particular way in which the sequences are varied to produce a composition is known as the 'method'. For example, the first 10 changes of the method known as Grandire Triples are: 1234567; 2135476; 2314567; 3241657; 3426175; 4362715; 4637251; 6473521; 6745312; 7654132; 7561423...

The bells are always numbered in ascending order of weight from 1, the lightest, treble, bell to the heaviest, tenor, bell. The name of the method usually indicates the number of bells in the ring; singles (4), doubles (5), minor (6), triples (7), major (8), caters (9) and royal (10). With 8, 10 or 12 bells, changes are usually rung on the 7, 9 or 11 lightest bells with the tenor bell always remaining the last bell in each sequence. A method terminates when the sequence returns to rounds and the first difficulty in devising a method is to make sure that this does not happen prematurely. The maximum

possible number of changes in a method, the 'extent', is the factorial of the number of bells, for example 5040 for triples. Normally, in ringing a peal a number of different methods will be used so as to keep the minds of the ringers exercised. Strictly, a 'peal' should contain at least 5000 changes, anything shorter is known as a 'touch'.

For the structural engineer the time taken for each change is important in calculating the dynamic response. The nominal time is  $2\frac{1}{2}$  seconds but it may, in practice, fall to just over 2 seconds. For example, the ringers at Over, Cheshire who, in 1950, rang 21600 changes (Bristol Surprise Major) in 12 hr. 58 min. averaged 2.14 seconds per change. To appreciate their feat it must be realized that a single error by any ringer would have invalidated the whole of this record peal. The longest peal ever rung was of 40,320 changes in 1761, taking 27 hours at an average of 2.41 seconds per change. However this was performed by relays of ringers so can hardly be supposed to count.

To the structural engineer the most important way of ringing a number of bells is known as 'firing' in which all the bells are rung simultaneously in each stroke. This is used to celebrate joyous occasions, normally only coronations or the more expensive weddings. It will be seen that this is more damaging than change ringing.

### Force input from the bells

To calculate the variation with time of the forces applied at the gudgeon pins by a single bell, the following formulae derived by Mr Lewis<sup>1</sup> are used.

If a bell has rotated by an angle  $\theta$  from the top-centre position, the horizontal thrust,

$$H = \frac{P}{3.05} \left( 2 \sin \theta - \frac{3}{2} \sin 2\theta \right) \quad (\text{Fig. 4a}) \text{ and the}$$

$$\text{vertical force, } V = \frac{P}{3.05} \left( 3 \cos^2 \theta - 2 \cos \theta + k^2/h^2 \right).$$

P is the maximum value of H (occurring when  $\theta=124^\circ$ ) given by:

$$P = 3.05 \frac{Wh^2}{h^2 + k^2}$$

where W is the weight of the bell and its fittings

h is the distance of their centroid from the axis of rotation

and k their radius of gyration about their centroid.

h is determined by direct measurement and then 'k' can be deduced by measuring the natural period 'T' of small swings where

$$T = 2\pi \sqrt{\frac{(h^2 + k^2)}{gh}}$$

Normally information provided by the bell-founder will include values of the maximum horizontal and vertical thrusts and of 'T'. For the ring of Holy Trinity the information in Table 1 was obtained from Messrs John Taylor & Co of Loughborough who also provided Reference 1 and were generally very helpful. These bells may be regarded as typical although the weight of even the tenor bell hardly compares with that of 'Tsar Kolokol' which weighed 1900 kN. As this fell from its supports and lost an 11 tonne piece from its side before it could be rung the comparison is perhaps not wholly relevant. 'Great Paul' and 'Big Ben' weigh 167 and 135 kN respectively.

The vertical loads are of interest when designing the bell-frame; their influence on the tower structure is small and was not investigated at Holy Trinity. To find the variation of the horizontal thrust with time, Mr Lewis's third equation has to be invoked.

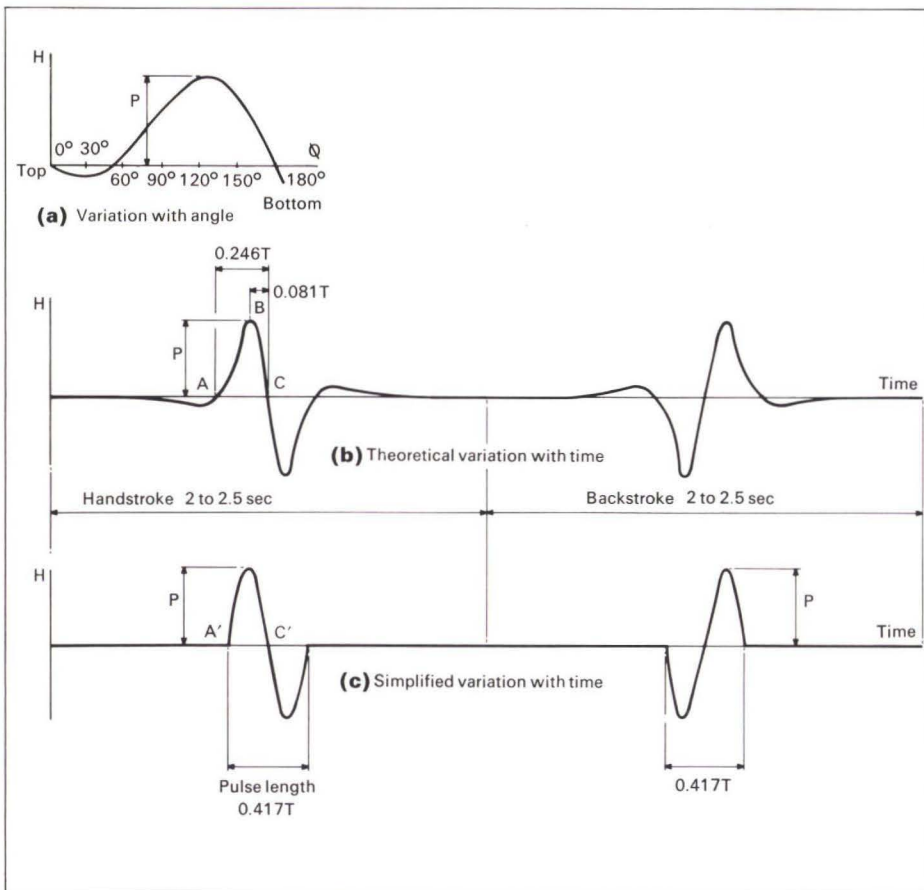


**Table 1**

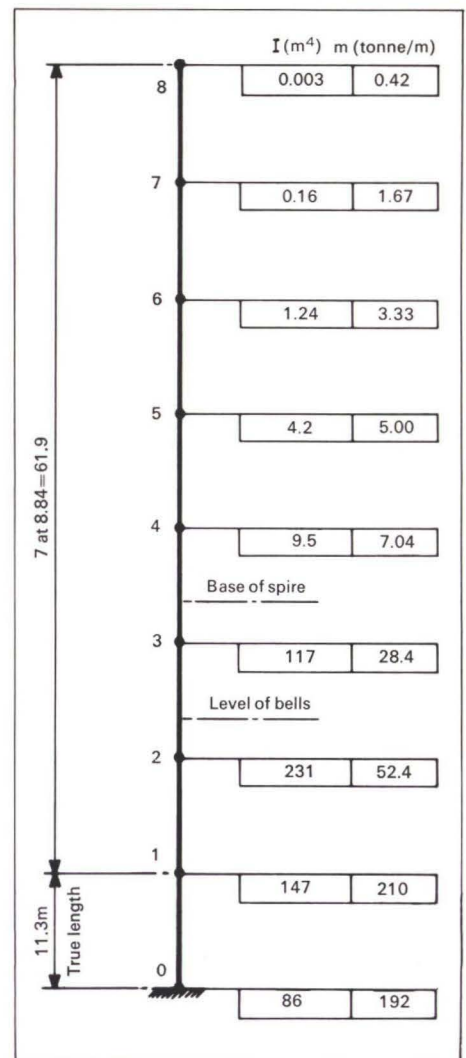
Bell no.	Diameter mm	W kN	T Sec	Maximum thrust	
				Horizontal (P) (kN)	Vertical (kN)
1	600	2.25	1.44	3.3	6.35
2	635	2.5	1.50	3.95	7.7
3	670	2.5	1.50	3.95	7.7
4	700	2.87	1.52	4.3	8.45
5	740	3.13	1.54	4.7	9.2
6	785	3.75	1.59	5.5	11.3
7	850	4.5	1.64	6.25	12.5
8	900	5.25	1.68	7.3	14.7
9	990	6.37	1.75	8.7	18
10	1120	9.38	1.85	11.65	24.8
		42.5		59.6	120.7

This states that the time to reach the position at angle  $\theta$  from top-centre is given by  $t = \frac{T}{4\pi} \int_0^\theta \text{cosec} \left( \frac{u}{2} \right) du$ , where T is again the period of small swings. Unfortunately, according to this, the time taken to reach any position is infinite (since the lower limit of the integral is infinite). There is a physical reason for this because Mr Lewis' formulae neglect the disturbing force applied by the ringer, without which it takes theoretically infinite time to move the bell even slightly off its equilibrium position at top centre. However, the time taken to reach bottom-centre ( $\theta = 180^\circ$ ) is known from experience to lie between 1 and  $1\frac{1}{2}$  seconds. This gives

point 'C' on the H-t graph on Fig. 4 (b). Working backwards from this point, the times between the critical points A, B and C drawn on Fig. 4 (b) can now be determined by the theory. It is convenient, although not essential, to replace this rather complex pulse by the equivalent single sine pulse of Fig. 4 (c). This has an amplitude equal to the maximum horizontal force and the pulse length 'p' is chosen as equal to  $0.417T$  so that the impulse between points A' and C' is equal to the impulse between points A & C of the real pulse. The theory gives the variation during the handstroke. The force-time variation for the backstroke repeats this but to opposite hand as shown in Figs. 4 (b) and 4 (c).



**Fig. 4**  
Horizontal force generated by swinging bell



**Fig. 5**  
Computer model for spire and tower response

**The response of the tower**

A computer program was specially written to estimate the response of the spire and the tower to dynamic loading from the bells. This required the structure to be represented by a single straight cantilever; for any given load-history the variation with time of the deflection and bending moments at points uniformly spaced along the beam could then be computed. The program used the technique (finite differences and linear forward integration with time) devised by Alistair Day for the Dynamic Relaxation Method. However, whereas in dynamic relaxation the vibrations are contrived to be heavily damped to yield a static solution, the tower vibrations were initially assumed to continue undamped.

The analytical model regarded as the most probable representation of the structure is shown in Fig. 5; the properties are to be assumed varying linearly between the nodal values. 'E' for masonry was taken as 16,000 MPa and the spire walls as 180 mm thick. Equivalent lengths and section properties were devised for the tower below the nave roof, calculated on the assumption that only the four piers under the corners of the tower resisted bending but that a large part of the mass and stiffness of the nave and transept resisted horizontal shear forces.

To estimate the natural periods of this structure a short uniform horizontal pulse was applied and the resulting velocities of the top of the spire plotted. This showed that the two gravest natural periods were 0.45 and 0.14 seconds.

The basic loading analyzed represented one stroke of the tenor bell. This was the first single sine pulse of Fig. 4 (c), with a pulse 9

duration of 0.75 seconds applied as a horizontal force at bell-frame level. Typical undamped response curves are shown on Fig. 7. These show a peak response during the pulse succeeded by a sequence of peaks spaced at the natural period of the structure. The amplitudes of the succeeding peaks were almost constant (give or take a few harmonics) and usually little different from the peak amplitude in the pulse.

The effect of a single stroke on all bells simultaneously was found by multiplying the basic response by the factor 5.1, the ratio of the sum of horizontal thrusts for all bells to the thrust for the tenor alone. This assumed, reasonably enough, that the pulses from all the bells started simultaneously. It also neglected the fairly small variation in the value of  $T$ , and hence pulse duration, between the bells.

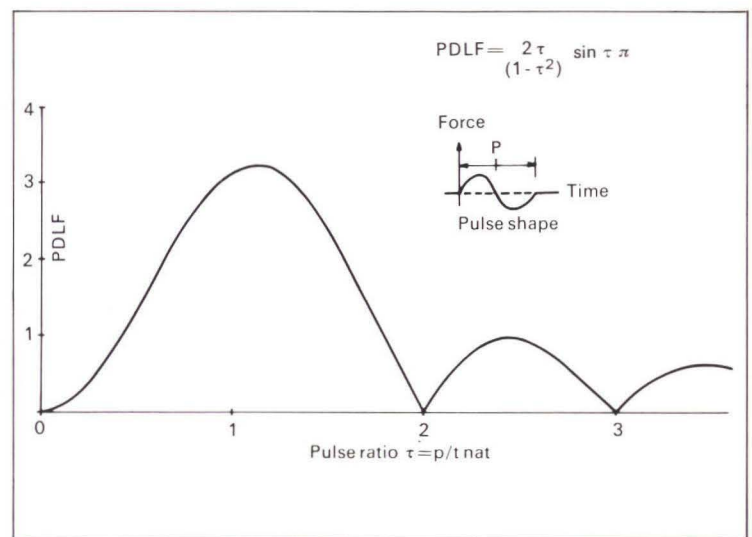
Repeated strokes of all bells, i.e. firing, was taken to be most damaging when the interval between each stroke (handstroke and backstroke) was an integer and a half times the natural period of the structure, for then all peaks would coincide. This could occur since 2.48 seconds ( $5\frac{1}{2} \times .45$ ) is quite a feasible interval between strokes; 2.03 seconds is probably unreasonably short. The logarithmic decrement of damping for the masonry was now taken to be 0.08 so that in free vibration each peak would be only  $\exp(-.08) = 92\%$  as high as the preceding one. Thus at each stroke the response from the previous stroke would have decayed to  $\exp(-5.5 \times .08) = 64\%$  of its initial value. The eventual maximum value of any response is therefore  $5.1 (R_0 + R_1 (.64 + .64^2 + .64^3 + \dots))$  i.e.  $5.1 (R_0 + .64 R_1 / (1 - .64))$  where  $R_0$  and  $R_1$  are the peak values of response to one stroke of the tenor bell respectively during and after the pulse.

### Properties

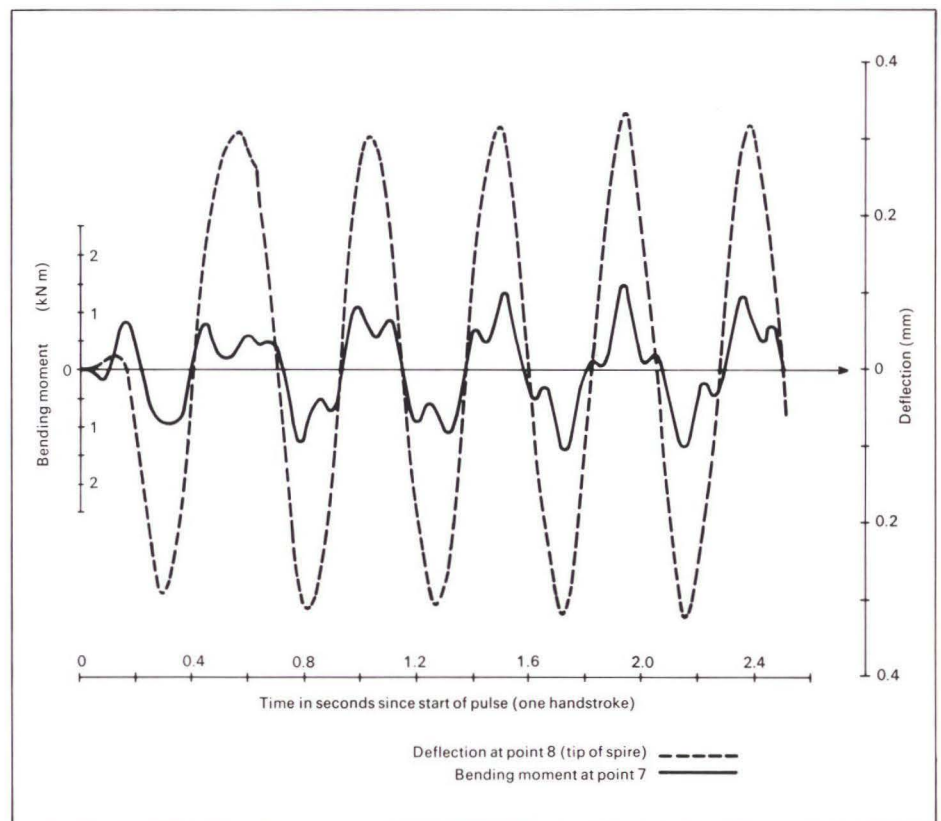
But the calculation could not end here for we ought not to have believed that we had assessed the properties of the spire correctly. Fig. 6 was prepared to see how sensitive the response might be to changes in these. This was derived analytically for a single degree-of-freedom system and shows how the persistent dynamic load factor PDLF varies with the pulse-ratio  $\tau$ . The PDLF was defined here as the ratio of the peak response (persisting after the pulse) to the response if the maximum horizontal force were applied as a static load. The pulse-ratio is the ratio of the pulse duration 'p' to the natural period of the structure. It is interesting to note that the greatest response occurs when the pulse length exceeds the natural period by 15% and not, as might be expected, when they are equal. (Fig. 6 also illustrates, if illustration were needed, how dangerous dynamic calculations can be if made blindly, especially with the powerful computer programs now available. For suppose that, using the power of such a program, the force input had represented the whole repeated sequence of forces due to firing, and that the chosen model of the structure had had a natural period equal to half the pulse length: Then the effect of one stroke would not, apart from some stray harmonics, add anything to the next stroke!)

In our first analysis the value of  $\tau$  was  $.75 / .45 = 1.72$  giving a PDLF of 1.35. Had our structure been modelled so as to give a natural period of 0.625 seconds, with  $\tau = 1.2$ , we should have expected to find basic responses 2.4 times those of the first analysis. And the longer period would have had another unwelcome effect. For, with only  $3\frac{1}{2}$  oscillations between each stroke ( $3\frac{1}{2} \times .625 = 2.19$ ), the response would only decay to 76% of its initial value. It was not impossible for the natural period to be 0.625 seconds; it would only require that the mass was

10 10% greater than assumed and the stiffness



**Fig. 6**  
Dynamic load amplification factor



**Fig. 7**  
Response of spire to swing of one bell

consistently only 57% of its assumed value. The program was therefore re-run with the structural model amended in this way. The resulting responses were found, in fact, to be multiplied as indicated by the above approximate approach. The bending moments caused by firing the bells were then taken to be a weighted mean of those from the two analyses, with the higher value weighted by a factor of two. This presumed that we could not be quite so unlucky as to have the worst properties of the spire combined with the worst timing by the ringers.

Fig. 6 may also be used to show that our argument was too facile when we found the effect of one stroke of all bells simply by summing their maximum horizontal thrusts. Allowing for the differing values of  $T$  for the different bells and the resulting higher PDLFs for the lighter bells the multiplication factor of 5.1 used earlier becomes, for the first analysis, 8.0. With the higher period of the second analysis, the effect is very much less significant and the factor 5.1 would be slightly reduced.

Change ringing was then considered; although less damaging than firing we still needed an estimate of its effect so as to decide if and when it could be permitted. During change ringing the peaks from all strokes cannot coincide as they may with firing; the contributions from earlier bells may be positive or negative by varying amounts. (This would not be true, incidentally, for a high frequency structure with a gravest period of about .025 seconds; but for such a structure the PDLF would be very small). Assuming the more critical natural period of 0.625 seconds for Holy Trinity and, for simplicity, equal time intervals of 0.22 seconds between each bell, it could be shown that the worst response occurred after a series of changes culminating in 4 3 9 5 2 8 1 7 6 10/3 4 9 2 5 8 1 6 7 10. The peak bending moments were then 30% of those that might occur during firing. If the intervals between bells could vary by 25% of their nominal values and the ringers (obeying Murphy's First Law) would do this in the way most damaging for the structure, then the

resulting bending moments would be 37% of the firing moments.

The calculated maximum sway of the top of the spire during firing was 11 mm.

The calculated bending moments in the spire during firing of the bells are plotted in Fig. 8 together with the bending moments due to a 50 m.p.h. wind; a strong gale. The bending moments to cause failure, defined earlier as occurring when cracks penetrated half-way across the spire, are also indicated. Bending moments causing a crack just to open may be taken as two-thirds of these. The graph shows how bell-ringing effects are more significant than those of wind near the top of the spire but are relatively unimportant near the base. They also show that the factors of safety under either bell-ringing or wind loads are much more critical near the top of the spire.

Following this work we reported that the bells could be re-hung provided they were accompanied by an anemometer with its dial plainly visible in the ringing chamber. 'Firing' was to be discouraged and should be prohibited in any wind stronger than a strong breeze. Change ringing would be allowed for anything less than a strong gale (50 m.p.h.) above which only a solitary bell might ring.

### The steeplejacks' initial inspections

Lack of funds prevented the church from taking advantage of our (albeit qualified) approval of the re-hanging of the bells (they were, in fact, subsequently sold) and we heard no more from Mr. Redgrave until early in 1972 when a further joint inspection of the spire was made.

This time it was evident that rusting of the tie bars was causing bursting stresses in the masonry around the anchor plates and we recommended that the ends of the rods should be exposed by opening up the masonry, that the rust should be cleaned off and the rods protected against rust prior to the masonry being reinstated.

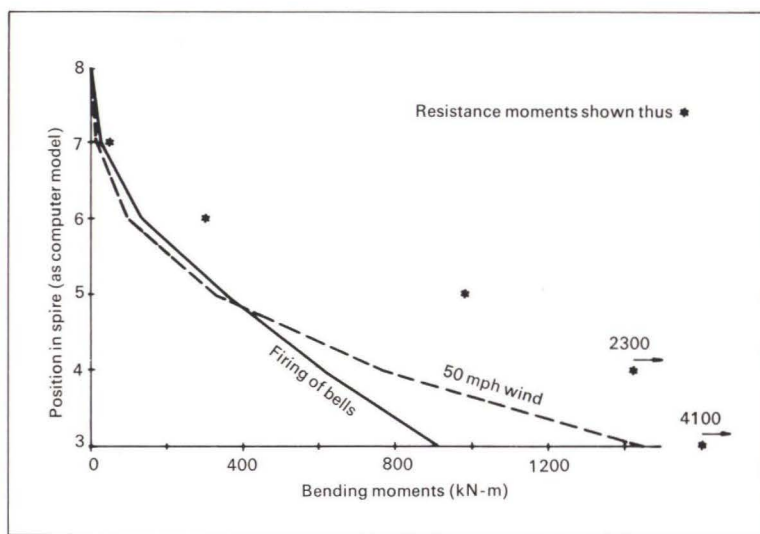
As part of the preparations for this work, an inspection was carried out by W. J. Furse & Company Ltd., a firm of steeplejacks and stone masonry contractors. Their findings caused us considerable concern: they estimated that weathering had reduced the thickness of the masonry to as little as 0.08 m in places!

We had made some allowance for weathering in our stability calculations but we had not imagined erosion on this scale, and whilst it was obvious that this was a local weak spot, calculations showed that a reduction of the average thickness from the assumed 0.17 m to, say, 0.12 m would seriously diminish the wind resistance of the spire, not only as a consequence of the reduction in dead weight but also because the compressive stresses could no longer be considered insignificant.

We had so far ignored the vane rod in our calculations, but we thought at this stage that it might for the time being, assist the stability a little by providing a tying down force to augment the stabilizing effect of the dead weight (an optimistic assumption as it turned out to be), but we needed to assess the stability more accurately in order to decide on what needed to be done and we therefore requested 'further and better particulars' of the thickness and strength of the stone.

Furses' extended their ladders and, in order to measure the thickness, drilled 16 mm holes through each facet of the spire at 11, 13.5, 19.5, 22, 30.5 and 33 m above the base. The results were interesting but not entirely comforting: The average of the thicknesses measured at the upper two levels was 0.20 m, at the middle two levels 0.20 m and at the lower two levels 0.12 m with a confirmed individual minimum of 0.076 m, indicating that erosion

**Fig. 8**  
Bending moments caused by firing of bells



had been most serious on the lower slopes of the spire, just above the transition between the very steep lower section and the more pronounced upper taper. In other words, we had lost most thickness where the girth was greatest and it mattered most!

The quality of the stone turned out to be no more encouraging: a 'fair sample' from the local quarry, judged by a mason to be 'better than some of the stone in the spire', was delivered to our Birmingham office with a request to pass it on by hand as 'the stone is rather friable and will not stand much rough handling'.

The laboratory managed nevertheless to cut prisms 76 mm long and 38 mm square, out of the sample. These were weighed and tested for compressive strength. Two prisms gave an average compressive strength, perpendicular to the bedding, of 12.7 N/mm<sup>2</sup>, another two gave a strength parallel to the bedding of 4.0 N/mm<sup>2</sup>. The average density of the four samples was 2030 kg/m<sup>3</sup>.

Both strength and density were significantly less than expected and whilst the very low strength, parallel to the bedding, might have been a function of the small size of the specimens we once again went through the calculations.

### The final check on wind stability

With better information on the density of the masonry and the thickness of the walls as well as the general geometry of the spire, a new and more detailed check on wind stability was made with the wind loadings now calculated to CP3: Chapter V Part 2: 1972. This was interpreted in an orthodox way with a basic wind speed of 44 m/sec (98 m.p.h.), a 50 year return period, and, rather conservatively, ground roughness Category (3) and Size Class C (15 second gusts). The variation down the spire of the resulting spire weight and wind moment is shown by the full lines on Fig. 9. The dashed line on this figure shows the nominal factor of safety against overturning. This safety factor fell below 1.8 for the top 4 m and the lowest 18 m of the spire.

If failure was defined, as in the earlier checks, to occur when cracks penetrated half-way across the spire, then the safety factor at the base was only 1.06. The dramatic reduction from the corresponding previous value of 1.65 can be attributed wholly to the 17% reduction in weight and the 28% increase in wind load. Under the design wind the calculated compressive stress in the stonework adjacent to the windows near the base was 2.3 MPa but, this increased by 56% if the wind load increased by 20%. Under the design wind, tensile cracks could in theory (in the absence of any tensile strength) open up at any level

but the depth of these cracks would exceed 10% of the width of the spire only near the top and the bottom. The wind moments in Fig. 9 assumed that the wind was blowing normal to one face of the octagon. With the wind blowing in a corner to corner direction the moments were increased by about 8% but the safety factors and compressive stresses were in fact no worse; cracks would, however, have started earlier and would have penetrated deeper.

### Further discoveries by the steeplejacks

While we were finalizing these calculations, Furses' were inspecting the condition of the anchor plates for the tie rods and the surrounding masonry and their findings indicated that the tie rods might have to be replaced rather than repaired. In a letter advising that their latest report was coming they also wrote:

'... We feel, however, that we should advise you without delay that ... the top 15 ft (4.6 m) or so of the spire moves. The movement appears to be from a bed joint which completely opens and closes (a width of  $\frac{3}{8}$ " (10 mm), when wind of this strength (approximately force 6) is blowing ...'

This was the solid tip of the spire which, although badly weathered, had not so far given us cause for concern, and in trying to find a reason why the solid tip of the spire should be rocking while the hollow part remained steady we stumbled on an, up till then, unpublished principle which, whilst perhaps not being the cause of the Pyramids having lost their tips, explains why so many spires are blunt-ended.

### The inherent instability of solid pyramids

Fig. 9 shows that the theoretical safety factor deduced from our calculations remained nearly constant with height up to the level where the spire changes from hollow to solid construction. However, within the solid portion of the spire, the safety factor decreased so sharply with height that further study was obviously required.

It was found by elementary statics that, for a uniform solid right cone of height 'x', density 'ρ', and vertex semi-angle 'α', the safety factor against overturning under a uniform effective wind pressure 'p', is given by

$$\frac{\rho g \tan \alpha}{p} \cdot x, \text{ if the cone is not anchored}$$

down. A similar expression is found for a pyramid. Thus for a given density, slenderness and wind pressure, a value of 'x' can always be found for which the safety factor is less than unity. It immediately follows that: 'If the masonry has negligible tensile strength then 11

a portion of the solid top of a pointed spire will always topple when the wind blows, no matter how gently it blows'. This 'Rule of Spires' is obviously a specialized variant of Murphy's Law but is perhaps unique within this codex in being capable of mathematical rather than experimental proof.

That the Rule is not a mere academic curiosity may be seen by considering a pointed spire of the same slenderness as that of Holy Trinity. Assuming a fairly steady wind pressure of 1.6 kPa and still negligible tensile strength, then the top length of the spire up to 3.3 m long might be expected to fall. To see the significance of the tensile strength we surmount the spire with a ball and cock, the cock being rather negligently stuck cross-wind. The calculated tensile stress at a level 3.3 m down from the apex is then either 0.1 MPa or 0.35 MPa depending on whether we use an optimistic or pessimistic calculation method. The optimistic method assumes, with Galileo, that the compressive stress is all concentrated at the leeward edge and the tensile stress increases linearly to the windward edge. The pessimistic method assumes, with *BS5628 Part 1*, the familiar M/Z-P/A. If we then increase the wind pressure by a factor of 1.4 these tensile stresses increase to 0.15 or 0.5 MPa.

All this suggests that the local strength of the top portion of a spire must be investigated carefully. This is borne out by the observable fact that many, although not all, spires are truncated. Holy Trinity's spire is in fact so truncated by an approximate length of 3 m (coincidence?). It is natural to speculate whether the Master Mason chose the amount of truncation by a rule of thumb derived from unwitting experiments on earlier spires or by graphical methods derived ultimately from the laws of statics. The part played by the vane rod is also of interest. Apart from its main function of attaching the spire furniture it presumably contributes to the stability of the top of the spire depending on the length to the first substantial anchorage. But did the early builders recognize this and take it into account?

Our musings over this came to an end with a further missive from Furses': 'the holding down rod stops at the bottom of the solid. A further rod commences approximately 6 ft (1.8 m) below this and continues to the base of the spire. The two rods are linked with 2 in x 1/8 in (50 x 3 mm) copper tape, this being a lightning conductor connection only' (!)

However, the real sequence of events was somewhat more protracted and hence less dramatic than it appears above. This concluded the catalogue of our problems: remedial action was becoming urgent.

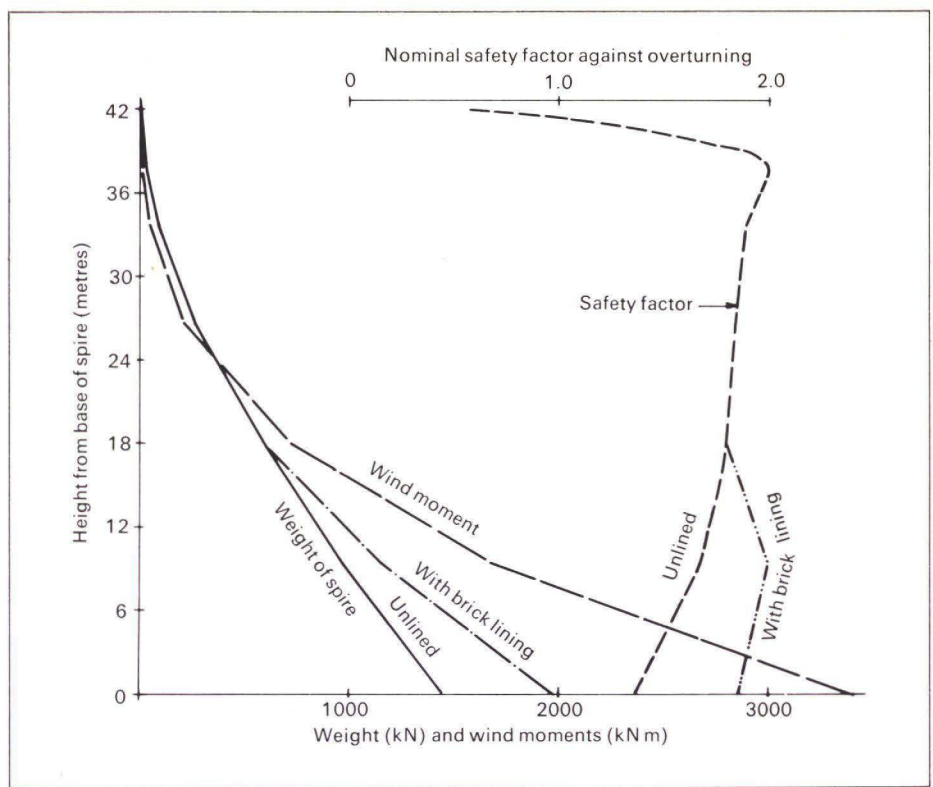
**The remedial works**

The results of Furses' and our own investigations could be summarized thus: the walls of the spire were too light and too weak to give adequate overall wind stability, the top was not adequately tied down and the rusting of the tie bars was bursting the masonry which was also suffering from weather erosion.

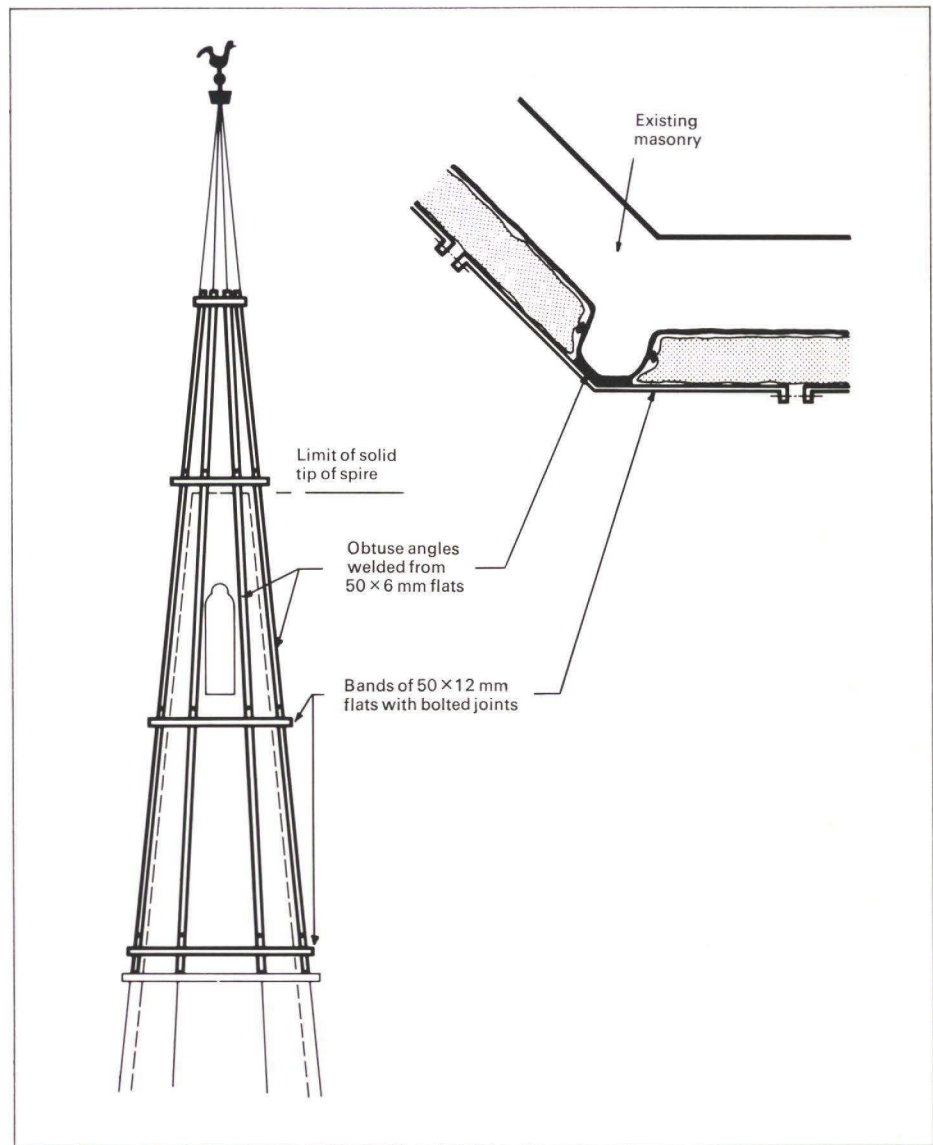
The rocking tip obviously called for the most urgent action, but the choice of the most appropriate remedy was dependent on what was to be done about the overall stability of the spire:

Rebuilding was of course the best way of dealing with the tip, but that would have necessitated an amount of scaffolding not far short of what a complete reconstruction of the entire spire would require, and whilst such a complete replacement would have been nice, it was financially impractical and (as will be seen) technically unnecessary.

Taking down the offending tip and capping of the stump until better times were seen as a last resort, disliked by all, the more so as it did not help the overall stability significantly.



**Fig. 9** Second wind resistance check: bending moments and factors of safety



**Fig. 10** The top cage: final design

Reconnecting the vane rod at the top and stressing it against the bell-chamber floor beam would very elegantly have solved the overall stability problem at the same time as anchoring the wayward tip. Unfortunately, it still meant dismantling the top with the attendant high scaffolding cost and it was also doubtful whether the bell chamber floor could take the uplift without expensive strengthening.

A suggestion of a glass-fibre-reinforced plastic replica was briefly shuddered at, before being dismissed as too difficult to hold down and, more important, not having an adequate, proven, lifespan.

In the end it was agreed to restrain the top of the spire within a 'cage' of structural steelwork extending far enough down to prevent the tip from rocking relatively to the lower part of the spire. It was considered by all concerned that, if suitably rust-protected and painted, such a cage would probably last 100 years and could be made to be visually acceptable, at the same time as allowing fairly quick procurement and erection by Furses' steeplejacks.

#### Compromise solution

Our first proposal for this top cage was substantially modified in the light of Furses' very practical comments, and we finished up with a compromise between the traditional steeplejacks' circumferential strapping, which mainly aims at limiting vertical cracks in chimneys, and our requirement which was for something to provide vertical tensile restraint (see Fig. 10). The steelwork was hot-dip galvanized, etch primed and painted with a bitumen-based paint to match the brownish-red stone.

The work of fabricating and erecting this strengthening was put in hand immediately and was carried out by Furses' in the early spring of 1977.

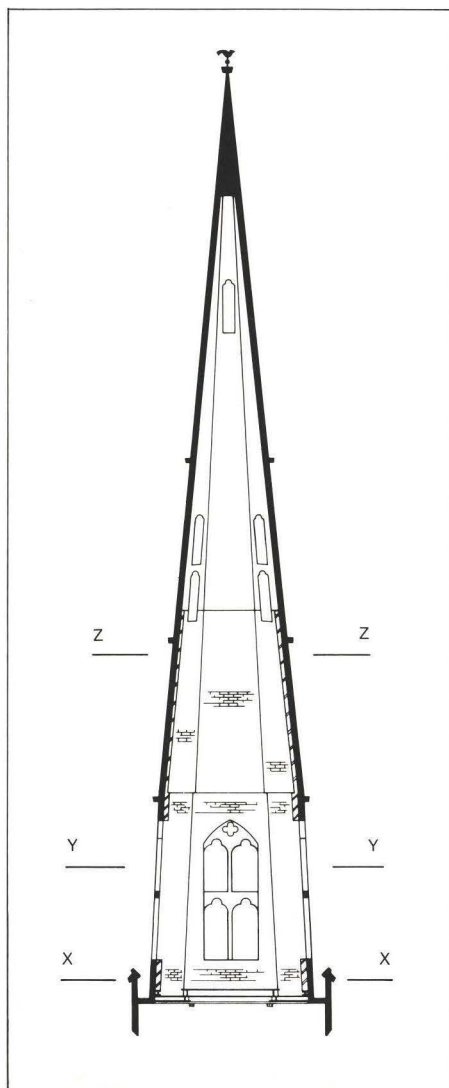
To improve the overall stability, we produced a design which more than replaced, on the inside, the structural thickness which had been eroded away on the outside. This replacement took the form of a lining of brickwork, built hard up against the inside face of the masonry and tied to it with fish-tail straps of stainless steel, fixed to the stone with small expanding anchor bolts. The brickwork was to be supported on encased structural steel beams, the ends of which penetrated the masonry shell of the spire and, resting on plinths of engineering brickwork, transferred the own weight of the brick lining and the loads due to wind forces, to the masonry of the tower below (see Fig. 13). The brick lining was to be 19.3 m high, the thickness for the lower 10.0 m was to be 115 mm on the solid facets and 230 mm on the facets with lights so as to compensate for the extra weakening of the masonry section. The top 9.3 m of the lining was to be 76 mm brick-on-edge all the way round. The effect of this brick lining on the spire weights and on the safety factors is shown by the chain-dotted lines in Fig. 9.

#### Vane rod renewal

The masonry under the anchor plates for the tie rods was badly cracked in places; so much so that it was doubtful whether effective anchorages could be achieved for the replacement rods. For this reason and also so as to enable the new rods to be installed before the old were removed, the new spiders were designed to be at slightly different levels. To allow renewal of the vane rod whilst preserving the bracing effect of the spiders the new 16 mm diameter stainless steel rods did not hook round the vane rod, as the old ones had, but radiated from split collars which were bolted together around the vane rod, which was to be renewed with 25 mm diameter stainless steel after the tie rod spiders had been replaced. The top of the new vane rod was to

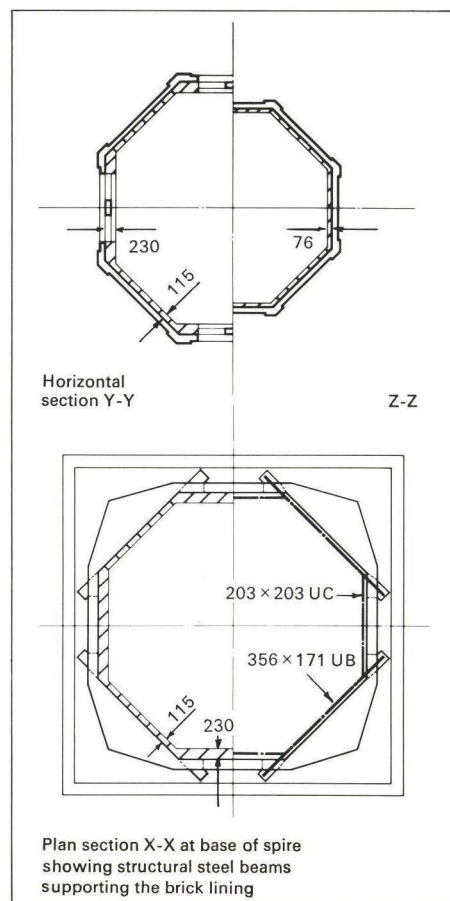


**Fig. 11**  
Tower and spire with inclined hoist and top cage  
(Photo: Poul Beckmann)



**Fig. 12**  
Vertical section through tower and brick lining

**Fig. 13**  
Horizontal sections through tower and brick lining



Plan section X-X at base of spire showing structural steel beams supporting the brick lining



**Fig. 14**  
Laying the brick lining  
(Photo: Poul Beckmann)

**Fig. 15**  
View up the spire showing new spiders,  
vane rod and completed brick lining  
(Photo: Poul Beckmann)

**Fig. 16**  
Spire seen through Cathedral porch  
(Photo: Poul Beckmann)

be anchored to a cross head of two steel channels back-to-back built into the hollow part of the spire so high up that adequate overlap with the tip cage was ensured.

All mild steel was specified to be hot-dip-galvanized and subsequently painted with pitch epoxy paint, thus ensuring maximum durability within the rather limited budget.

All the remedial works were completed during the autumn of 1980.

#### References

- (1) HEYWOOD, Sir A. P., *editor*. Bell towers and bell hanging. Central Council of Ringers, 1914. Chapter 4, pp. 54-60: 'A short summary of a series of experiments and calculations mainly directed to expose the fallacy of the theory that elasticity in a bell-frame relieves the strain of the fabric of a bell-tower', by E. H. Lewis.
- (2) SAYERS, Dorothy L. *The nine tailors*, Gollancz, 1934.
- (3) JACKSON, Canon L. *The Parish Church of the Holy Trinity, Coventry: a guide written by the Vicar*. New edition, The Parish Church, 1971.

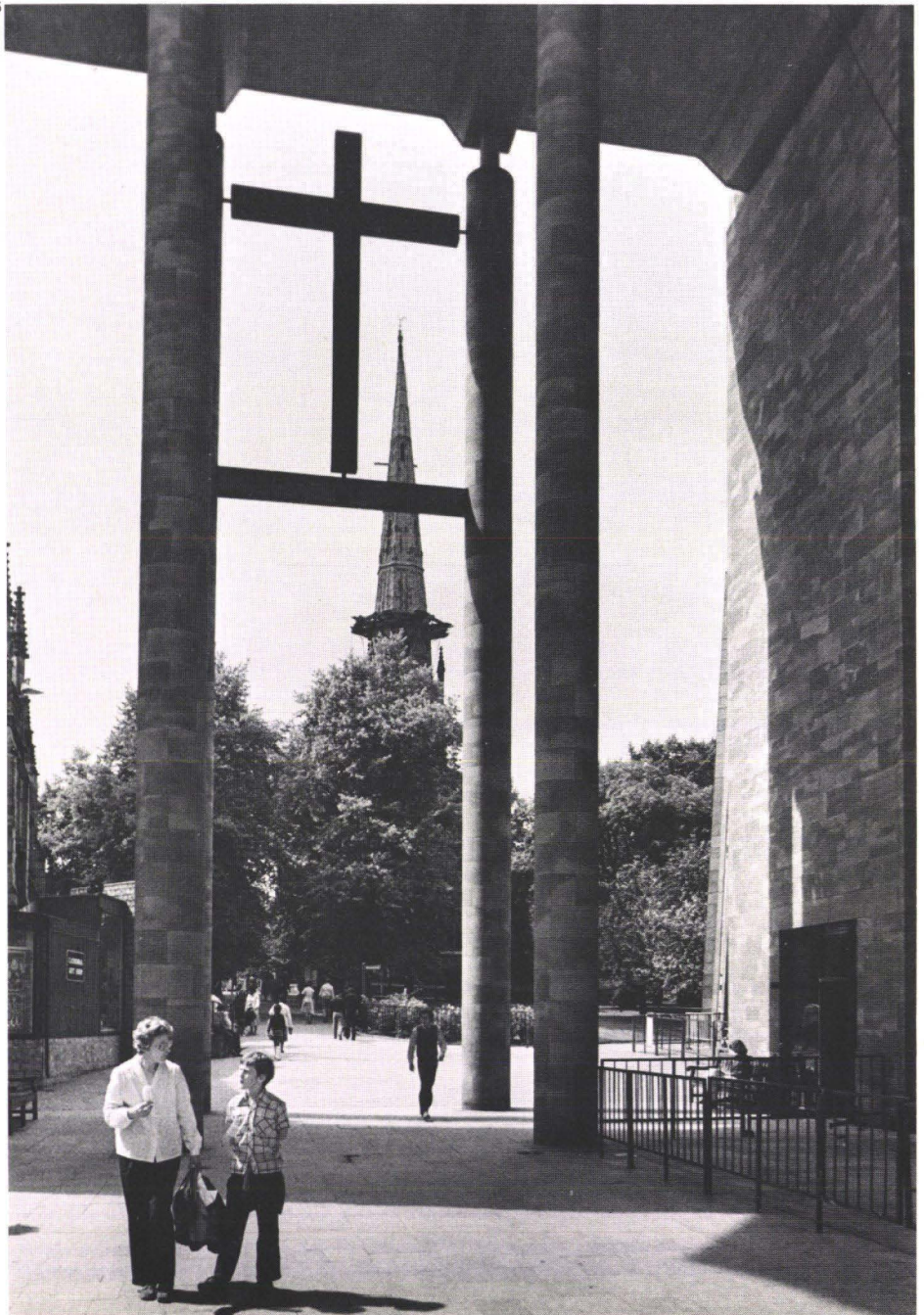
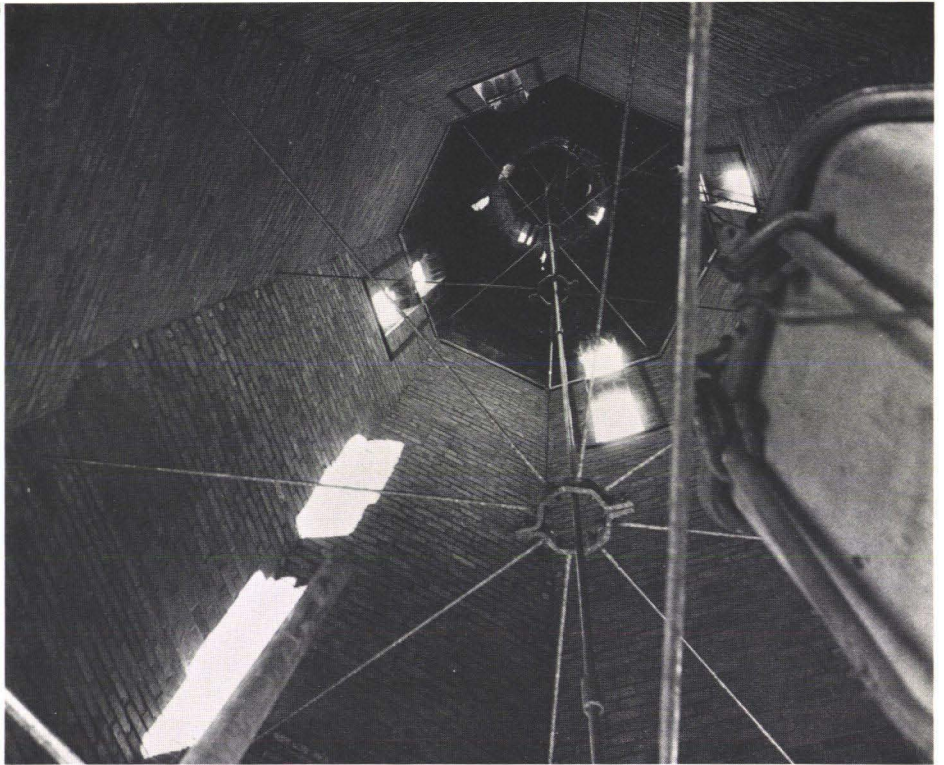
#### Credits

*Architect*  
Claude F. Redgrave  
*Main contractor*  
J. W. Furse & Sons Ltd.  
*Quantity Surveyor*  
C. H. Osborne & Partners

#### Acknowledgement

Mr. Redgrave provided the major part of the information on which the introduction is based.

John Taylor & Co. of Loughborough provided the information in Table 1 as well as Reference



# Study for a deep water testing tank

John Tyrrell

## General

As the exploration for oil and gas moves into deeper waters, current offshore technology is being extrapolated beyond existing experience. The need for a new deep water testing facility to cater for the future demands of marine technology has been under review by the Science Research Council Marine Technology Directorate (SRC) and the National Maritime Institute (NMI) for some time.

A number of parallel studies have been commissioned recently jointly by the SRC and the NMI to assess the feasibility of a large-scale laboratory facility for hydrodynamic research and testing. The main studies include:

- (1) A technical study of the modelling and/or testing problems likely to be encountered
- (2) An engineering/economic study based on an outline technical specification with the main features varied parametrically
- (3) A market research-type study to assess the likely demand of such a facility.

Following an initial presentation Ove Arup & Partners were commissioned to carry out the engineering/economic study in November 1979.

## Scope of the study

It is envisaged that the provision and operation of such a facility would be of national importance and should, therefore, meet the combined needs of industry, universities and Government.

The technical specification identified a number of parameters to be considered for the proposed facility and these include the tank plan area, water depth, wave generation, current, carriage, craneage and wind. Values for the maximum, basic and minimum requirements were given for each parameter as well as stating further options to be considered.

Engineering implications of the variable parameters were to be considered in terms of design, manufacture and installation, and construction.

Cost estimates were to be built up and presented to indicate the influence of the relevant parametric variations.

An unencumbered green field site was chosen as the basis for the study but the relative benefits of locating the facility adjacent to existing facilities of the NMI at Feltham and Glasgow University were also to be assessed.

## Current state of the art

There are a number of existing facilities both in this country and abroad where ship keeping and hydrodynamic testing are carried out. Eight major facilities were carefully chosen to highlight the planning, design and operation of particular relevance to the study and, armed with a list of questions, we duly visited them. It soon became apparent that the technical specification far exceeded the capability of any existing laboratory and our task amounted to a challenge.

## The tank

Nine permutations of tank sizes were given varying from a maximum size of 100m x 50m x 12m deep to a minimum of 50m x 25m x 8m deep.

The method of circulating the water to produce the required current and the wave generation aspects were fundamental considerations in the design of the tank structure.

The proposed general arrangement of the tank is illustrated by the section in Fig. 1 and consists of a reinforced concrete box approximately 7.5m wide around the perimeter of the building and forming access aprons at the top, together with a base slab to the tank.

In order to reduce the energy losses in pumping the water through the side channels and improve the general flow characteristics, allowance was made for shaping the concrete in the form of a curved profile, particularly around the corners and at both ends.

## Wave generation

The specified wave requirements were as follows:

	Max.	Basic	Min.
Maximum height of regular waves (m)	2	1.5	1
Wavelength range (m)	1 to 30		

The wave maker was to be capable of producing:

- (a) Uni-directional long crested waves
- (b) Multi-directional irregular wave spectra
- (c) Irregular wave periodicity up to high return periods
- (d) Breaking waves in a controlled manner.

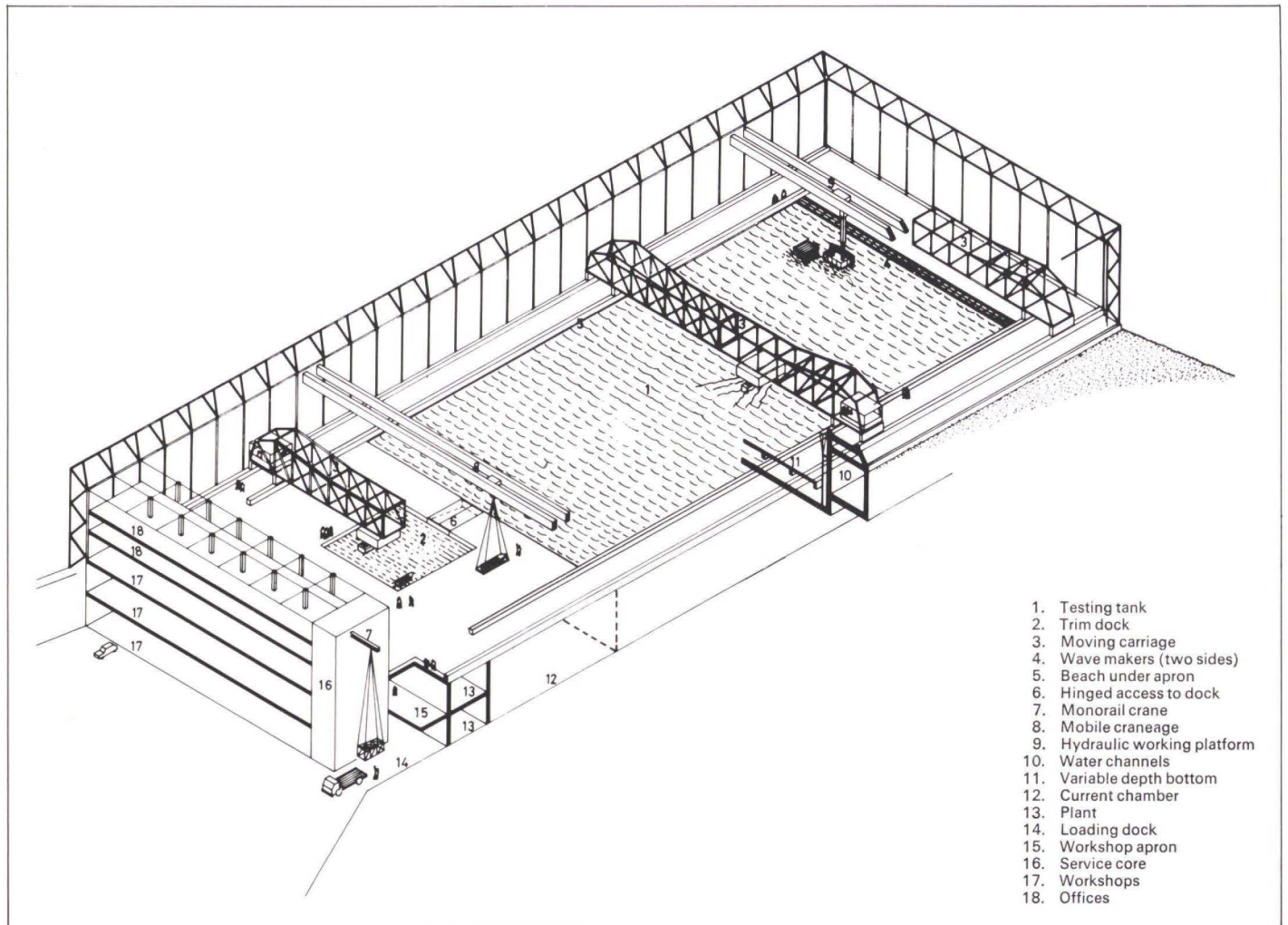
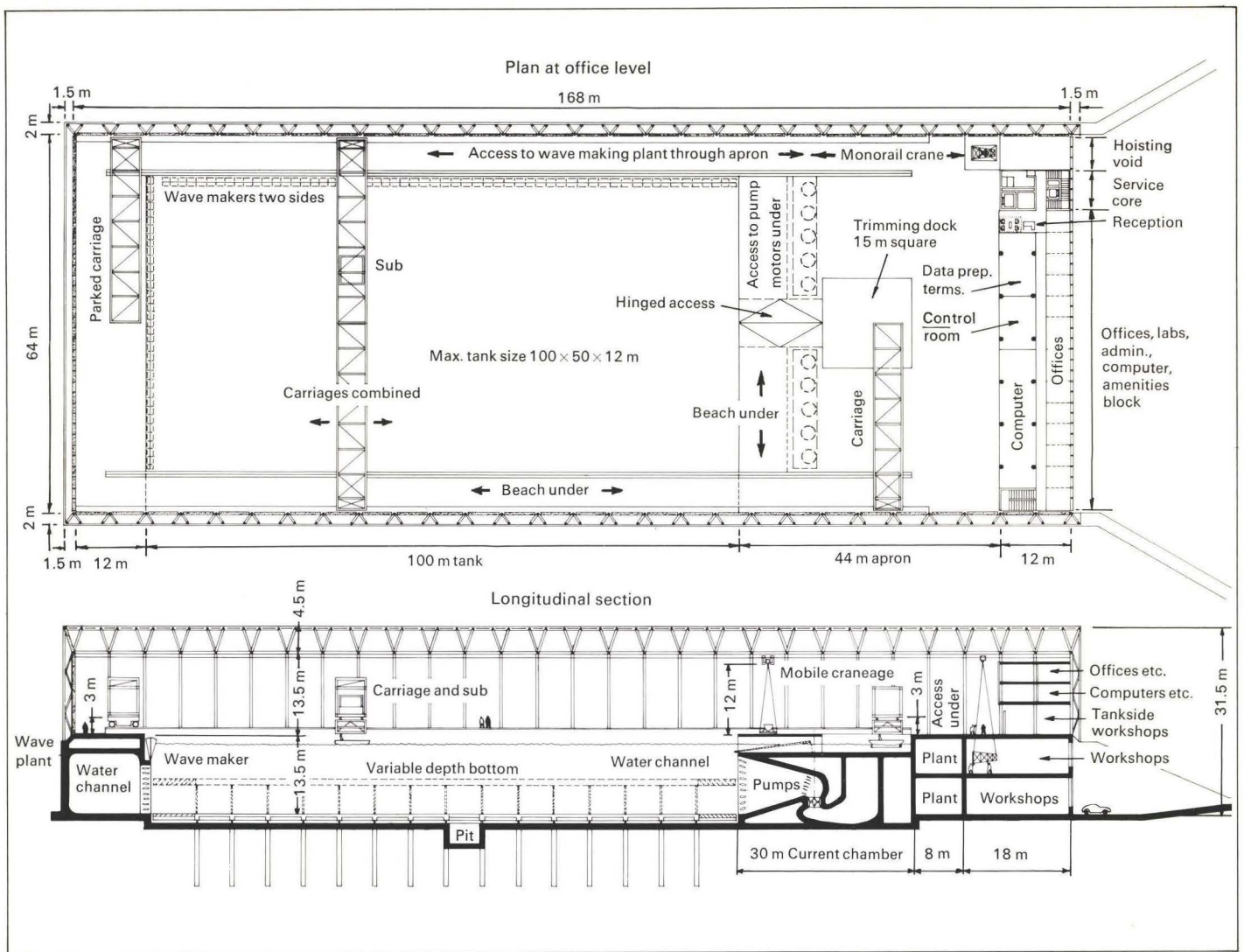


Fig. 1  
Isometric view of tank



**Fig. 2**  
Plan and section of tank

Recent work at Edinburgh University, as part of the Department of Energy's wave energy research programme has led to the development of a second generation of wavemakers which utilize advanced electronics to enable an exacting specification for short crested seas to be achieved. The wavemakers consist of narrow low-inertia paddles arranged vertically in a piano key lay-out and hinged at the bottom. The motion of each paddle is individually controlled to generate both regular and irregular waves in a predetermined manner. Different input signals and phase shifts between adjacent paddles enable short crested wavefronts to be generated in varying directions across the tank. Wave absorption systems, based on feedback from the hydrodynamic pressure on the water face of the paddle and its angular motion, enable any reflected waves to be absorbed and new waves to be generated simultaneously. This feature allows good control and repeatability of wave conditions without the pressure of unwanted reflected waves and thus enables the plan area of the tank to be significantly smaller than would otherwise be the case. A similar arrangement was proposed for the new facility with wavemakers on two adjacent sides of the tank but driven by a precision servo-hydraulic system.

In order to eliminate the effects of reflected waves from the remaining two sides of the tank, 'beaches' would be provided under the aprons.

#### Current

The requirements for current include:

- (1) A maximum speed of 0.5m/sec. available over the whole tank area

- (2) A capability of complete variation of the current direction relative to the predominant wave heading

- (3) Variable vertical current velocity profile maintaining a limited flow capability over the whole depth range.

The combined requirements for wave, current and water depth variations led to the conclusion that the recirculation of water for current generation should take place outside the confines of the tank. The tank would therefore be surrounded by a water duct which would house all the current generation and profile control equipment.

Two methods were studied for the generation of current; a number of large pumps in parallel and high velocity water jets to induce the total flow.

Pumping the total water quantity was proposed as the preferred solution in so far as it is more straightforward and the current flow pattern is more predictable. To achieve the maximum current speed over the full width of the tank corresponding to a water flow rate of 300m<sup>3</sup>/sec., 10 of the largest pumps available in this country would be required.

A louvre system installed at both ends of the tank was devised to control the current flow and achieve a variable velocity profile.

#### Wind

A maximum mean wind speed of 12.5m/sec. was specified over a limited area but over any part of the tank in any direction. The wind field should also be capable of being moved to follow a model.

It was envisaged that the wind requirement would be provided by means of a capsule

containing a battery of axial flow fans. The capsule would be suspended from one of the main tank carriages by means of a small traversing carriage and a bogie unit to allow the full 360° rotation.

#### Craneage and carriage

Emphasis was placed on the flexibility of use of the facility and the arrangement was designed to provide a suitable system, duplicated as necessary for maximum utilization during testing operations.

At roof level three separate cranes would allow the interchange of bogies if required, thus permitting a model to be easily transferred between any location on the apron and tank.

A system of four half carriages, each cantilevering out from rails on the side aprons over half the tank width was proposed. Each half-carriage could be rapidly locked and unlocked with an opposite half carriage to form a very rigid carriageway spanning the full tank width if required.

A small 'delta carriage' could be suspended from sub-carriages to permit small immediate movements in any direction when required to follow freely moving or self-propelled models.

#### Water depth

Two methods of achieving a fully variable depth of water were considered. The first was to adjust the quantity of water in the tank and the second was to install a movable floor which could be fixed at any depth below the surface of the water.

The preferred method was the movable floor which could be controlled automatically and adjusted rapidly to limit disruptions to the testing operations.



The system comprises a vertically adjustable steel platform with small positive buoyancy, held vertically in position by cables and horizontally by contact at several points with buffers around the sides of the tank. Depth adjustments could be made by either tensioning the cables to lower the floor, or easing the cables off to allow the floor to rise. Steel shafts, fastened to the underside of the platform, would pass into deep sockets in the concrete floor of the tank. The shafts could be rigidly locked at the required level by a remotely operated hydraulic clamp system at the exit of each pocket.

#### Data systems

The proposed arrangement for data acquisition and transmission consists of a central computing system located in a remote control room and smaller computers mounted on each of the four carriages as back-up to allow for maximum reliability.

Each test, including the stages of instrumentation and calibration, would be controlled from the carriages. Data could either be acquired and recorded direct on the local minicomputer or transmitted to the central compiling installation by the acquisition system on each carriage.

The acquisition system would be required to accept and transmit for storage and subsequent analysis the data from a series of 64 analogue transducers with the model under test. Data from the transducers would be read at 100Hz for a 10-minute test period.

Three data transmission systems from the carriage to the control computer were investigated; an umbilical cord, a radio telemetry link and an optical laser communication system.

The central computer system was designed for:

- (1) Receiving data during test runs and recording this data on a permanent storage medium, in real time

- (2) Analyzing data from test runs
- (3) Monitoring and displaying data during the calibration of equipment
- (4) A word processing operation to produce reports for the users
- (5) Programme development.

#### The building

A single building envelope was proposed to house all functions and activities associated with the tank facility. The envelope comprises a clear span deep steel truss system with cladding of composite sandwich construction.

The principal concept of the building organization was to locate the workshops, offices and general amenities at the end of the facility adjacent to the deep apron.

The workshops were located on two levels within the concrete podium with the varied functions planned to suit their sequence of activities and relationship to apron level.

A zone for tank side workshops was located on the end apron to provide a facility for instrumentation, fine engineering and adjustments. Above this area, a secondary structure containing all offices, control room, computer complex, laboratories amenities and storage facilities was proposed.

Natural daylight tends to stimulate algae growth in the water and although daylight and outside awareness were considered for the elevations at all levels, no glazing was provided over the tank area.

#### The facility in operation

Part of the brief included an assessment of the type of organization and management structure likely to be required to run a facility of this type.

Information obtained from the various visits to existing establishments provided a rough outline of the typical staffing levels.

It was envisaged that the facility would be patronized by industrial organizations as well as academic and government establishments. Close links would need to be maintained with universities and other research organizations to ensure that new developments in experimental techniques and theoretical hydrodynamics would be incorporated in the testing procedures and interpretation of results.

#### Costs

An assessment of the capital costs for the building and main equipment was based on preliminary designs for the various parameters and from information obtained from specialist manufacturers.

A confidence band was applied to the costs and in the case of the primary equipment, allowance was made to reflect the 'state of the art' and the need for system development and testing.

Estimated running costs for the facility were also provided.

#### Conclusion

The study has provided a stimulating insight of a relatively new sphere of interest to us. A number of people throughout the firm have contributed in some way and our involvement with Arup Associates on the building organization and costing was, from our viewpoint, a fruitful one.

Our report was well received by the client but what happens next will, to a large extent, depend on the results of the other concurrent studies. However, we are hopeful that with whetted appetites, our study will lead to further work in these as yet uncharted waters.

#### Credit

Client  
Department of Industry

## A computer system for building services design

Robert Aish

#### Introduction

There have been a number of highly successful demonstrations of complex computer-aided design systems. Typically such systems have attempted to integrate geometry modelling, graphic display and manipulation facilities with complex multi-attribute evaluation of building performance. It would appear that it is not yet technically nor economically feasible to apply such an integrated CAD system in an organization such as ours. The technical limitations concern the inability of these systems to handle the complex geometry and the varied construction techniques which our architects and engineers wish to use. The economic limitations concern the cost of providing all design engineers with graphics terminals, processing power and storage devices with reasonable access times. Thus the first aspect of this paper is to consider our objective. The objective is to make a profitable use of computers given the present and expected relative costs of computers and design staff. If it is not possible to provide sufficient computing resources so that every aspect of every engineer's work is done within a fully automated CAD system, then there is an alternative task of designing a computing system which can be accessed by

all engineers and used predominantly for calculation tasks.

Arups employ about 150 Building Services engineers which represents 18% of all engineering staff. We have a large time-sharing and batch processing computer system (DEC-10) located in London and desk top computers (HP9845) in our regional offices. Thus although there is considerable

computing power available this has to be distributed to a large and varied user community.

Arups are in a unique position, being one of the few engineering consultants that develop their own computer programs. This development procedure involves co-operation between client committee, The Mechanical and Electrical Development Group (MED) and the Computer Group.

The way in which this co-operation functions can best be described by comparing it with the normal design process used in the construction industry.

The client committee represents the interest of the end user, MED operates effectively as the consultant and the Computer Group fulfils the functions of the contractor.

The dialogue between these groups continues throughout the program development period since there is often interaction between calculation procedures and the effective use of computing resources.

An example of this is the recently developed THERMAL program suite.

#### THE THERMAL PROGRAM SUITE

This suite consists of the following programs:

- HEAT: steady state heat loss calculations.
- COOL: maximum instantaneous cooling loads calculations using cyclic weather data.
- ENERGY: energy analysis using recorded weather data and simulation techniques for both the performance of the building fabric and building services.

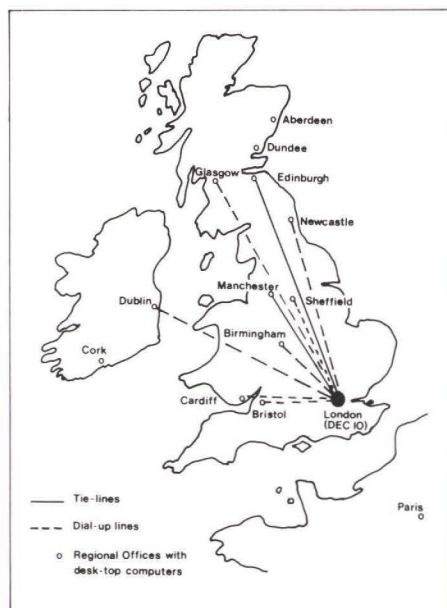


Fig. 1 Geographical distribution of Arup regional offices and computer network

```

OVE ARUP PARTNERSHIP - PROGRAM HEAT                PAGE : 7
JOB TITLE : WORKED EXAMPLE FOR HEATING PROGRAM    MADE BY : RB
JOB NO. : 5289/82                                DATE : 17-Dec-79

**ROOM INFORMATION FOR THE HEATING PROGRAM - ROOM NO.> 20

ROOM NO. ROOM LENG WIDT HEIG AIR AIR CHANGES CONVECTIVE
      NO. (M) (M) (M) (C) PER HOUR OR RADIANT
      20 5.00 4.00 3.00 18.00 1.00 C

ROOM NO. OF NO. OF
NO. SURFACES ROOMS OF
EXT INT THIS TYPE
20 1 1 1

EXTERNAL SURFACES FOR ROOM > 20

ROOM SURFACE LENGTH HEIGHT SURFACE WINDOW NO. OF
NO. REF. NO. (M) (M) TYPE TYPE WINDOWS
20 700 4.00 3.00 10 30 1

INTERNAL SURFACES FOR ROOM > 20

ROOM SURFACE WIDTH HEIGHT SURFACE TEMP. OTHER SIDE
NO. NO. (M) (M) TYPE IN WINTER(C)
20 800 5.00 3.00 10 10.00

HEAT LOSSES FROM ROOM MODULE 20

LOSS THROUGH EXT. WALLS 290.70 W
TOTAL GLAZING LOSS 324.90 W
LOSS THROUGH INT. WALLS 348.00 W
TOTAL VENTILATION LOSS 418.49 W

TOTAL HEAT LOSS 1382.09 W

VOLUME OF ROOM 60.00 M3

HEAT LOSS PER CUBIC METER 23.03 W/M3

ENVIRONMENTAL TEMPERATURE 18.00 DEG.C
INTERNAL AIR TEMPERATURE 20.14 DEG.C
MEAN RADIANT TEMPERATURE 16.93 DEG.C

NUMBER OF ROOMS OF THIS TYPE 1

**END

```

**Fig. 2**  
Output from the HEAT program

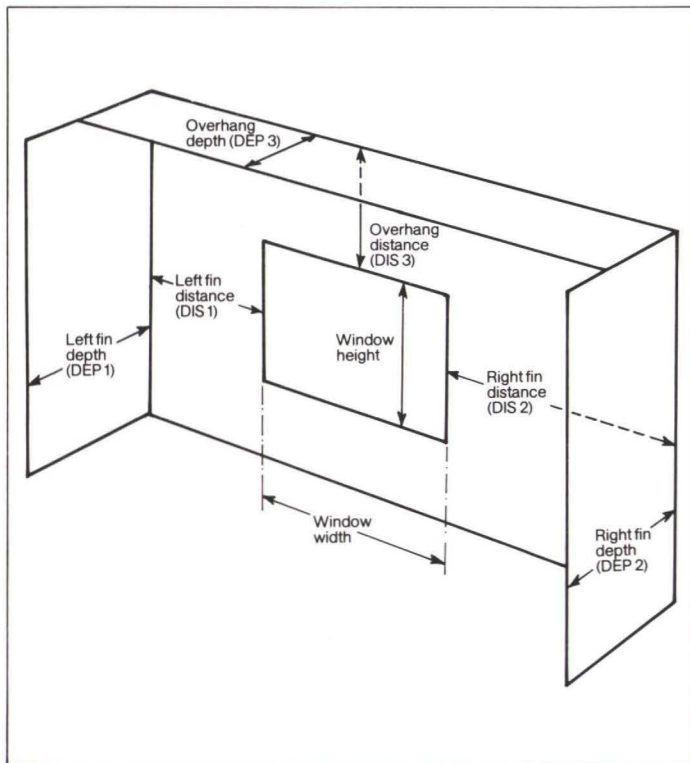
HEAT, COOL and ENERGY can each be used with building data for up to 100 different room types. The programs have a common file structure so that the same building data can easily be used with any of the programs.

**HEAT: Steady state heat loss calculations**

This program calculates heat losses from rooms with either convective or radiant heating devices, following the method described in Book A of the CIBS guide. Typical output for a single room is given in Fig. 2.

Although this program could equally well be implemented on a programmable calculator as on our DEC-10 time-sharing system, there are advantages in using this system. This is particularly evident when large building refurbishing projects are being undertaken.

For example, if the user wishes to test alternative glazing and heating systems for a large number of rooms, then he need only alter those data items under consideration without having to enter repetitively all the room data for each new run of the program.



**Fig. 3**  
The geometry of shading devices for windows which can be specified for the COOL and the ENERGY programs

**COOL: Maximum instantaneous cooling loads**

The COOL program calculates cooling loads and the steady state heat losses for:

- (1) Up to 100 different room types
- (2) Collections of any number of particular room types grouped into zones
- (3) The collection of zones served by one central plant.

The program takes into account:

- (1) U-values and absorption and admittance coefficients of the walls
- (2) The solar gain factors for glazing
- (3) The tilt and orientation of the glazing
- (4) The geometry of shading devices (see Fig. 3)
- (5) Simple occupancy, lighting and machinery utilization profiles, and diversity factors for these profiles.

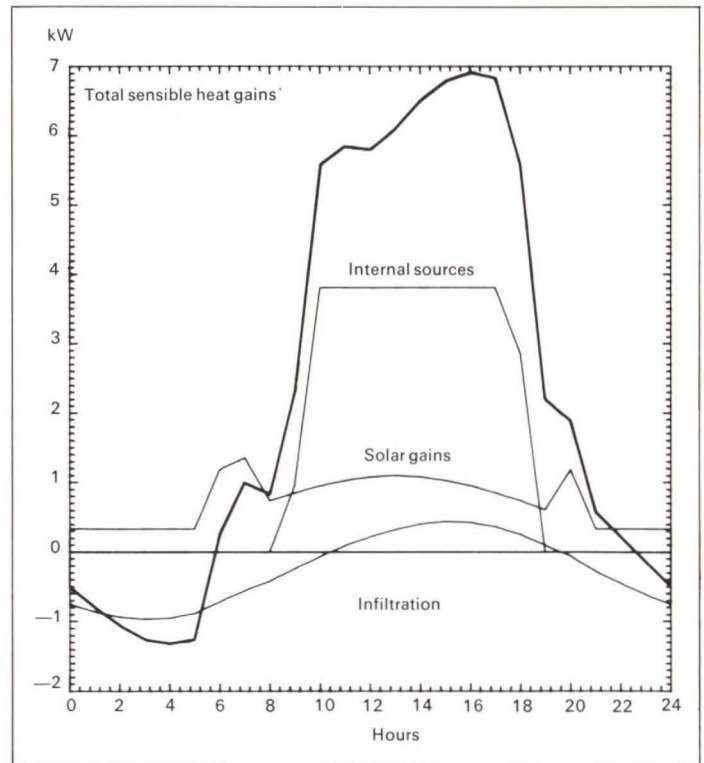
The program calculates the loads for a single typical day for each month. Climatic data used by the program consist of:

- (1) The design dry bulb temperature for each month
- (2) The corresponding minimum dry bulb temperature for each month
- (3) The average daily maximum wet bulb temperature for each month.

The program calculates for each hour of the design day for each month the following sensible heat gains:

- (a) Solar gains through windows
- (b) Gains due to periodic flow through the structure
- (c) Gains due to steady flows through the windows
- (d) Gains due to lights, occupants and machinery
- (e) Ventilation loads caused by infiltration and the following latent heat gains:
  - (a) Gains due to occupants and machinery
  - (b) Ventilation loads caused by infiltration.

The user can select which output tables are actually required to be printed. Alternatively output can be obtained in graphical form (see Fig. 4).



**Fig. 4**  
Graphical output for the COOL program

The building design team can use the COOL program to consider the effect on the size of both cooling and heating plant of such factors as:

- (a) The overall form of the building, its aspect ratio and orientation
- (b) The design of windows, their material, size and geometry of shading devices
- (c) Alternative occupancy and utilization patterns.

**ENERGY Energy analysis program**

This program uses a more detailed model of the energy transfers within the building, and a model of the air-conditioning or heating system, together with hourly weather data, to calculate the energy consumption of the building for each hour for a complete year.

The sum of the energy supplied in the form of different utilities and used in various building services is the final output of the program

(see Figs. 5, 6, 7). These different output tables can be combined into any energy flow diagram (Fig. 8).

The ENERGY program uses essentially the same description of the building, its zones, room types, walls and windows that are used by the COOL program. However, much of the energy consumption of a building is determined by the way it is used. While the COOL program is only used to search for the maximum cooling load, only the maximum

5

JOB NUMBER - 5289/02				
JOB TITLE - TEST FOR ENERGY PROGRAM				
MONTH	ELEC	GAS	OIL	PEAK LOP
MONTHLY TOTALS (GIGAJOULES)				
1	1682.36	3683.42	0.00	0.00
2	1495.01	3651.47	0.00	0.00
3	1718.58	4091.27	0.00	0.00
4	1586.16	3265.80	0.00	0.00
5	2045.35	3318.84	0.00	0.00
6	2105.81	2992.79	0.00	0.00
7	2197.37	2683.44	0.00	0.00
8	2361.29	3031.74	0.00	0.00
9	2091.12	2891.62	0.00	0.00
10	2061.18	3180.04	0.00	0.00
11	1716.23	3627.05	0.00	0.00
12	1575.07	3643.21	0.00	0.00
QUARTERLY TOTALS (GIGAJOULES)				
1	4895.95	11426.16	0.00	0.00
2	5737.31	9577.43	0.00	0.00
3	6649.77	8606.80	0.00	0.00
4	5352.48	10450.30	0.00	0.00

**Fig. 5**  
Energy consumption supplied by different utilities

7

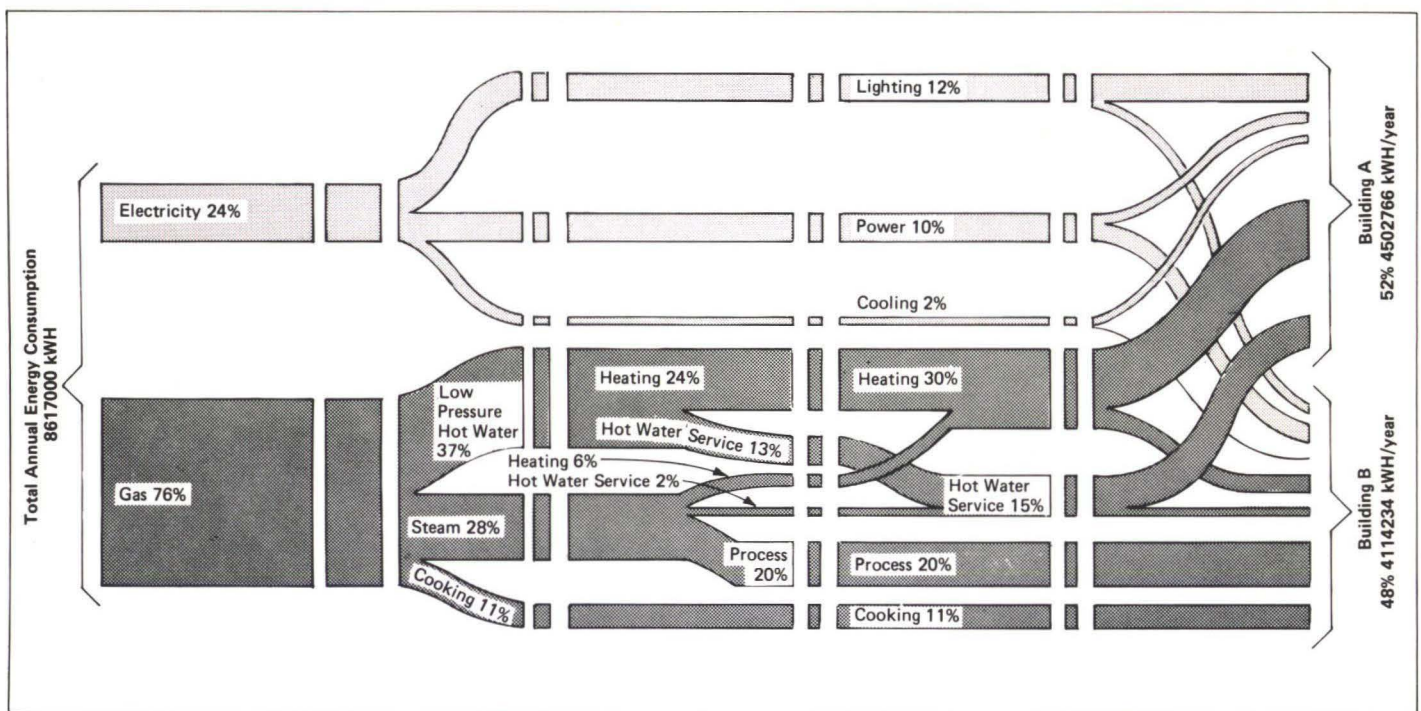
JOB NUMBER - 5289/02				
JOB TITLE - TEST FOR ENERGY PROGRAM				
MONTH	ELEC	GAS	OIL	PEAK LOP
MONTHLY TOTALS (GIGAJOULES)				
QUART. MAX. DEMAND FOR QUART. NO - 1				
LOAD	9.63	20.18	0.00	0.00
HOUR	17	18	0	0
DATE	25	7	0	0
MONTH	1	3	0	0
QUART. MAX. DEMAND FOR QUART. NO - 2				
LOAD	10.94	19.42	0.00	0.00
HOUR	17	18	0	0
DATE	15	3	0	0
MONTH	6	4	0	0
QUART. MAX. DEMAND FOR QUART. NO - 3				
LOAD	11.27	17.15	0.00	0.00
HOUR	17	9	0	0
DATE	10	28	0	0
MONTH	8	9	0	0
QUART. MAX. DEMAND FOR QUART. NO - 4				
LOAD	10.75	19.54	0.00	0.00
HOUR	17	18	0	0
DATE	3	27	0	0
MONTH	11	11	0	0

**Fig. 6 below**  
Monthly and quarterly energy consumption by different services

**Fig. 7**  
Maximum quarterly demands for energy supplied by different utilities

6

JOB NUMBER - 5289/02													
JOB TITLE - TEST FOR ENERGY PROGRAM													
AIR CONDITIONING PLANT				HOT WATER		LIFTS AND ESCALATORS	LIGHTING		MACHINES	ANCILLARY EQPT			
FANS	PUMPS	FRIG	HEAT	PUMPS	HEAT		LETT.	SERV.		NO 1	NO 2	NO 3	
MONTHLY TOTALS (GIGAJOULES)													
1	252.3	14.0	26.2	2049.9	1.2	1633.5	959.1	369.2	0.0	60.2	0.0	0.0	0.0
2	224.0	7.9	0.0	2166.5	1.1	1485.0	871.9	335.3	0.0	54.7	0.0	0.0	0.0
3	259.3	9.1	0.0	2383.5	1.3	1707.8	1002.7	383.2	0.0	63.0	0.0	0.0	0.0
4	225.5	21.0	72.6	1780.8	1.1	1485.0	871.9	339.2	0.0	54.7	0.0	0.0	0.0
5	263.1	54.5	277.5	1611.1	1.3	1707.8	1002.7	383.2	0.0	63.0	0.0	0.0	0.0
6	248.8	61.9	407.3	1359.3	1.2	1633.5	959.1	367.3	0.0	60.2	0.0	0.0	0.0
7	247.8	65.9	554.3	1124.2	1.2	1559.3	915.5	355.2	0.0	57.5	0.0	0.0	0.0
8	270.2	72.2	568.7	1324.0	1.3	1707.8	1002.7	383.2	0.0	63.0	0.0	0.0	0.0
9	243.5	61.7	458.5	1332.4	1.2	1559.3	915.5	353.2	0.0	57.5	0.0	0.0	0.0
10	249.9	58.9	362.7	1546.5	1.2	1633.5	959.1	369.2	0.0	60.2	0.0	0.0	0.0
11	249.8	17.3	61.3	1993.5	1.2	1633.5	959.1	367.3	0.0	60.2	0.0	0.0	0.0
12	237.3	8.3	0.0	2084.0	1.2	1559.3	915.5	355.2	0.0	57.5	0.0	0.0	0.0
QUARTERLY TOTALS (GIGAJOULES)													
1	735.6	31.0	26.2	6599.9	3.6	4826.3	2833.7	1087.7	0.1	177.9	0.0	0.0	0.0
2	737.5	137.4	757.4	4751.2	3.6	4826.3	2833.7	1089.7	0.1	177.9	0.0	0.0	0.0
3	761.5	199.8	1581.5	3780.6	3.6	4826.3	2833.7	1091.7	0.1	177.9	0.0	0.0	0.0
4	737.0	84.5	423.9	5624.1	3.6	4826.3	2833.7	1091.7	0.1	177.9	0.0	0.0	0.0
2971.5	452.6	2789.1	20755.7	14.4	19305.0	11335.0	4360.8	0.3	711.7	0.0	0.0	0.0	



**Fig. 8**  
Energy flows for a building complex derived from annual consumption data from the ENERGY program

occupancy and lighting usage need to be considered. But for a full energy analysis a more detailed approach is required which can allow the user to describe precisely the utilization of the building. The ENERGY program allows the user to specify utilization profiles for:

- (1) Central environmental conditioning plant
- (2) Occupancy
- (3) Lighting
- (4) Utility lighting
- (5) Hot water supply
- (6) Machinery utilization
- (7) Vertical transportation systems
- (8) Three different types of ancillary equipment.

Up to seven different day profiles can be defined for each type of activity or service. Thus each type of day can have a utilization profile for each activity or service. These day types can then be assigned by the user to days of the week to constitute a schedule for the central plant. For example a departmental store might have four types of profiles:

- (1) A typical working day profile (assigned from Monday to Thursday)
- (2) A late night shopping profile (assigned to Friday)
- (3) A half day profile (assigned to Saturday)
- (4) A holiday profile (assigned to Sunday).

Each room type may have its own weekly schedule of profile types so that the activity and utilization pattern for services for any particular room can be different from that for the building as a whole.

In addition up to 20 non-standard days may be specified. These override the normal weekly cycles of day profiles. For example, if day 120 is a public holiday it can be assigned to a holiday profile and this profile will be taken in preference to whatever profile is normally assigned to the day of the week on which the 120th day occurs.

The ENERGY program uses recorded weather data. A library of weather data files is available and new files can be added from weather tapes written in a number of different nationally defined formats.

The ENERGY program calculates the hourly cooling or heating load required by each room type to maintain the design conditions,

and then calculates the energy consumption required by the central plant to produce and distribute hot or chilled water or air to satisfy these demands, giving the defined capacity of the central plant and its efficiency/utilization characteristics. (This assumes that the capacity of the cooling and heating system has been found using the COOL program).

The program allows the user to specify different air-conditioning and heating systems and to mix different systems within the same building. These systems are:

- (a) Compensated perimeter heating — with and without thermostatic radiator valves — with and without local time switching
- (b) Constant volume with terminal reheat
- (c) Four pipe fan coil units
- (d) Variable air volume — with and without terminal reheat
- (e) Dual duct induction units.

The program also allows the user to specify different control strategies for the central plant and for each room.

First, if a constant volume system is used then the user can specify the minimum and maximum air supply temperatures. The minimum air temperature must be capable of offsetting the maximum heat gain, while the maximum air temperature must be capable of offsetting the maximum heat loss for the air supply rate specified for the terminal unit for each room.

Second, a proportional band can be defined. For example, a proportional band of 4°C allows the space temperature to vary 2°C either side of the design temperature and means that under full heating the temperature will be 2°C below the controlled temperature and conversely, under full cooling, 2°C above it. Selecting the proportional band enables a more economic use of energy to be achieved if a precise space temperature is not required.

Third, the percentage saturation of air supplied in each room can be specified.

Fourth, for each zone the extract air as a percentage of supply air can be specified. This enables different zones or the whole building to have a positive or negative pressure.

Fifth, for each zone the percentage minimum fresh air can be specified to be used under

conditions where the outside air temperature is greater than the return air temperature.

Sixth, damper control for each zone can either be done by temperature or enthalpy.

Seventh, the user can select whether or not each zone will have winter humidification.

Eighth, frost protection can be specified for the whole building together with the minimum space temperature allowed.

#### Using the energy program

The computer program enables the engineer to simulate the operation of the energy consuming building services systems. This can be done prior to detail design of the building and its systems or after the building is completed and operating.

The main applications of this program are the following:

- (1) Energy conservation in design
- (2) Energy consumption reduction during operation of the building
- (3) Feasibility studies for retrofitting/refurbishing of buildings and services systems.

#### (1) Energy conservation in design

The program can be used to consider various possible alternative system solutions in the system design and/or preliminary design phase of the building. The program can also be used to determine the influence of the building shape, facade, glass and shading, insulation, air tightness. Because of the effect on the energy consumption of the building of the type of HVAC system selected, the computer program makes it possible to determine the energy consumption for the alternative types of air-conditioning systems.

After selecting the type of HVAC system, the energy consumption and power demand program for the particular selected HVAC system, and therefore of the building, is also influenced by the size and routing of the main and sub-distribution system with its various velocities, pressure drops, pressure balancing devices and equipment arrangement in plant rooms.

Sometimes the design brief for the services systems limits the total allowable cost of energy consumption for the project. This has to be taken into consideration in the preliminary design of the building and the architect needs the various energy consumption budgets to determine the optimum

combination of services and structural system during the design phase.

The program enables the designer to under-size the capacity of equipment and check the resultant internal space conditions for the various times of the day during the various seasons.

**(2) Energy consumption reduction during operation of the building**

Total cost of the energy consumption is determined by two factors:

(a) Demand charges

These can be reduced by:

- (i) Power factor correction equipment
- (ii) Maximum demand control and/or limiting devices
- (iii) Optimum equipment stopping and starting schedules.

(b) Fuel/energy consumption

Energy consumption can be reduced through optimum operation of the equipment.

The computer program can assist in:

(i) Determining the optimum stopping and starting schedule of the major pieces of equipment

(ii) The influence of varying control settings of air and water supply by major equipment

(iii) The influence of temperature variations in the room

(iv) The influence of energy saving devices such as evaporative cooling and economizer cycle

(v) The influence of the increase in fan and pump horsepower through inadequate maintenance and mal-operation of capacity control equipment.

The ENERGY program can be used to determine the increase in energy consumption through inadequate closing of windows, improper control of shading devices, air leakage and infiltration through the façade and extended operation of the illumination system for after hour cleaning.

**(3) Feasibility studies for retrofitting and/or refurbishing of buildings service systems**

The usage of the computer program is very similar to the application described for energy conservation in design. The only difference is that the limitations imposed by the existing building must be taken into consideration.

Sometimes simulation of the existing method of operation of the HVAC system and comparison with a slightly modified method of operation will show that substantial modifications of the system are not really necessary to achieve reduction in energy consumption.

The simulated building operation by means of the program will show that:

- (a) Revised equipment stopping and starting schedules
  - (b) Changed method of operation of economizer dampers
  - (c) Usage of evaporative cooling
  - (d) Resetting and master scheduling of air and water temperatures, etc.
- can result in considerable savings in running costs.

**Other building services programs**

Associated with the THERMAL suite are two small stand alone programs:

- (1) ADMIT which calculates the admittance of composite building elements.
- (2) The thermal performance of building element program which can be used to calculate the running and capital costs associated with different thicknesses of insulation, within composite building elements. This program can be also used to identify condensation in such composite elements. Typical output is given in Fig. 9.

There are three further groups of programs associated with the THERMAL suite. These are:

(1) STEMP: Summer time temperatures program which enables detailed examination of specific rooms in a building to determine whether air-conditioning is necessary.

(2) LIGHT: This program suite enables the engineers to consider a number of design and performance variables associated with a single room and its glazing. These factors are:

- (a) Daylight (see Fig. 10).
- (b) Use of artificial light (linear or point source on vertical or horizontal surfaces)
- (c) Sun paths on specified windows or

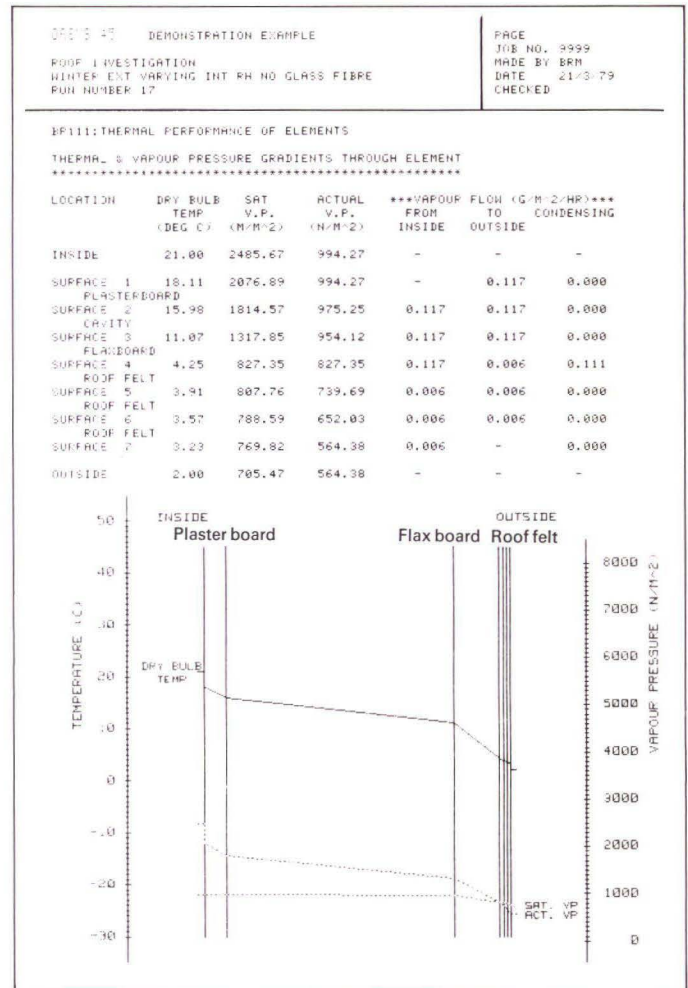
surfaces at any latitude, tilt and azimuth (see Fig. 11).

(3) Distribution programs for pipes and ducts—

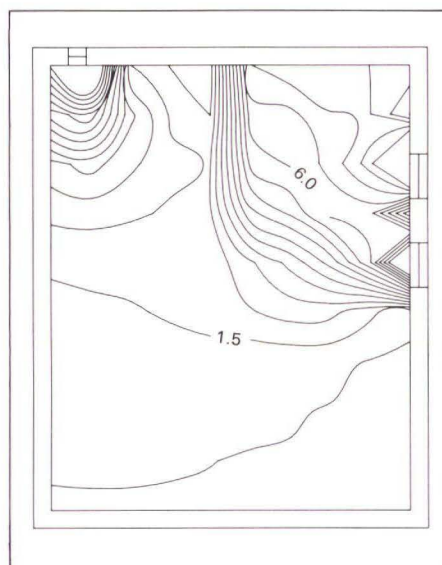
PIPE 1: pipe sizing for two pipe systems  
 PIPE 2: analysis of existing pipe systems and valve settings for two pipe systems

DUCT 1: duct sizing using:  
 — static regain  
 — constant pressure drop  
 — velocity reduction

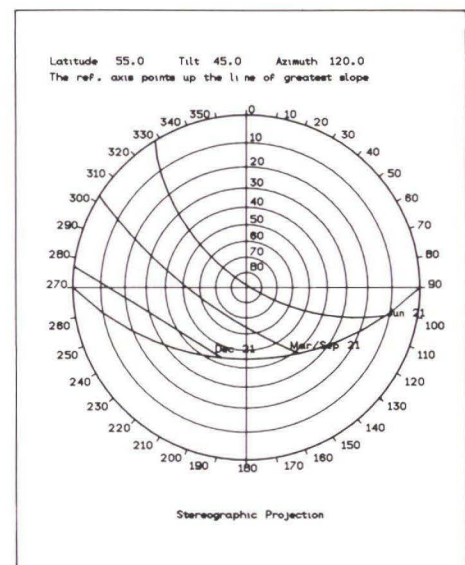
DUCT 2: analysis of existing duct systems. In most cases programs using the same calculation procedure are available on the HP9845.



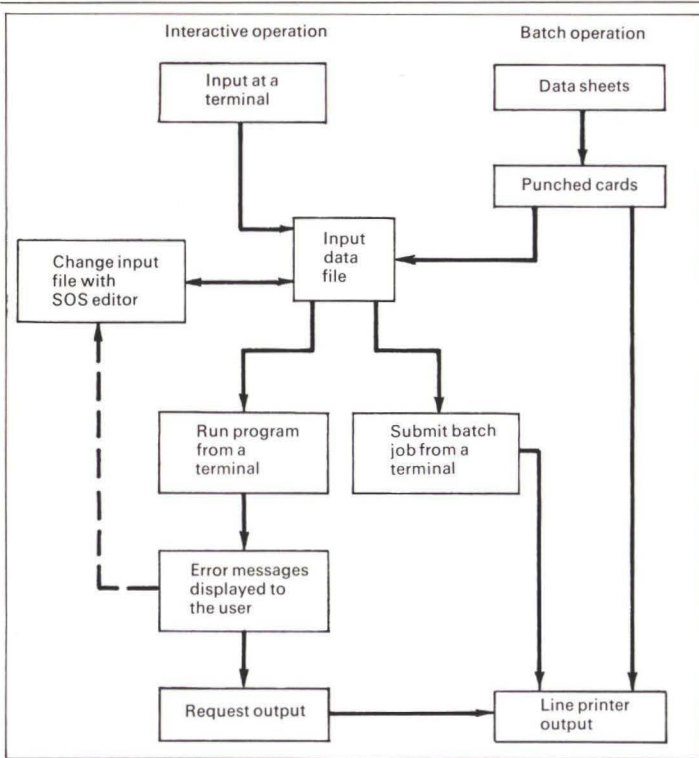
**Fig. 9** Output from the thermal performance of elements program



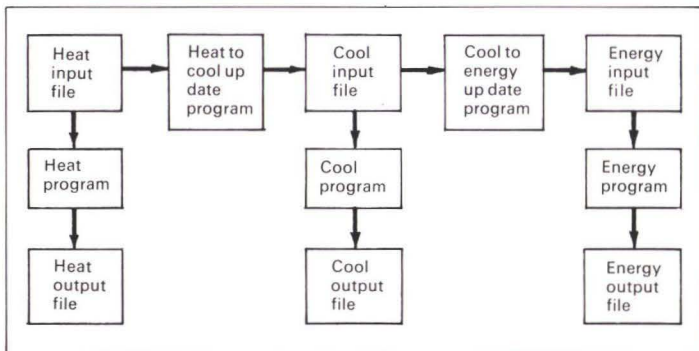
**Fig. 10** Output of the daylight program showing percentage daylight contour



**Fig. 11** Output of AGNES sun path program



**Fig. 12**  
The organization of the data entry/job control/data vetting/output system for the THERMAL suite



**Fig. 13**  
Using the HEAT, COOL and ENERGY programs with the UPDATE program

### User Interaction

In the past the emphasis during program development has been nearly exclusively centred on the important process of developing the appropriate calculation methods. The result of this is that users, who can appreciate the utility of these computer-base methods, have sometimes been frustrated because the design of the user interface has not been matched to their skills.

To overcome difficulties we have developed a data entry/job control/data vetting/output system for the DEC10 with the following facilities:

(1) It allows traditional batch operation for the remote user who wishes to use data sheets/punched cards as input.

(2) It allows the more experienced user to use different aspects of the program interactively from a terminal. Fig. 12 shows that any combination of data entry and/or running the program and/or receiving output can be achieved either at the terminal or in batch mode.

(3) The input data files for each program are divided into identifiable modules and the data in each module is clearly captioned. This allows the users easily to modify the data or remove erroneous values using the standard SOS editor.

(4) The data entry/data vetting/job control system has been designed to be easily applied to other programs and has been applied consistently across the THERMAL suite and to other building services programs, thus the users need only to learn one set of commands and conventions.

A logical system of input data modules has been developed for the THERMAL suite to describe the building and systems data. The amount of information required by each module is dependent on the program being run; HEAT requiring the minimum amount of data and ENERGY the maximum.

(See Table 1 for data modules)

```

OVE ARUP PARTNERSHIP - PROGRAM ENERGY
JOB TITLE : TEST FOR ENERGY PROGRAM
JOB NO. : 5289/02

**SYSTEMS DATA FOR THE ENERGY PROGRAM

HEATING SYSTEM DETAILS
HEATING IS HEATING BOILER HTG PUMP FROST MINIMUM
CAPACITY ELECTRICAL EFFIC. POWER CON PROT? TEMP
(KW) (Y OR N) (%) (KW) (Y OR N) (C)
6000.00 N 80.00 10.00 Y 13.00
*>WARNING : HEATING CAPACITY OUT OF RANGE (0 TO 1000) > 6000.00

COOLING SYSTEM DETAILS
REFRIG COOL TOWERS CHLD WATER TOWER COND C.W WET REFRIG CON.WAT.
CAPAC CONS NO. FLOW RETURN DES LWT PUMP PUMP BULB CONS COOLED ?
(KW) (KW) OF (C) (C) (C) (KW) (KW) (C) (KW) (Y OR N)
7000.0 15.0 4 5.0 12.0 30.0 40.0 30.0 19.0 1700.0 N
*>WARNING : REFRIG. CAPACITY OUT OF RANGE (0 TO 1000) > 7000.00
*>WARNING : REFRIG. PLANT POWER OUT OF RANGE (0 TO 1000) > 1700.00

HOT WATER SUPPLY SYSTEM DETAILS
H.W.S. IS H.W.S. BOILER PRIMARY PUMP SECONDARY PUMP H.W. STORAGE
CAPACITY ELECTRICAL EFFIC. POWER CONS POWER CONS CAPACITY
(KW) (Y OR N) (%) (KW) (KW) (M3)
1500.00 N 80.00 1.00 0.40 25.00
*>WARNING : HOT WATER SYST. CAPCTY OUT OF RANGE (0 TO 1000) > 1500.00

FANS
ZONE FAN POWER FAN DAMPER EXTR. AS MINIMUM HUMIDITY COIL OFF
NO. SUP. EXT. CNTRL. CNTRL. % OF SUP. FRESH AIR CONTROL DEW PT.
(KW) (KW) (%) (%) (%) (%) (DEG C)
1 160.0140.0 1 2 90.00 30.00 1 8.00
*>WARNING : SUPPLY FAN POWER OUT OF RANGE (0 TO 100) > 160.00
*>WARNING : EXTRACT FAN POWER OUT OF RANGE (0 TO 100) > 140.00
2 80.0 70.0 1 2 90.00 30.00 1 8.00
3 120.0105.0 1 2 90.00 30.00 1 8.00
*>WARNING : SUPPLY FAN POWER OUT OF RANGE (0 TO 100) > 120.00
*>WARNING : EXTRACT FAN POWER OUT OF RANGE (0 TO 100) > 105.00
4 160.0140.0 1 2 90.00 30.00 1 8.00
*>WARNING : SUPPLY FAN POWER OUT OF RANGE (0 TO 100) > 160.00
*>WARNING : EXTRACT FAN POWER OUT OF RANGE (0 TO 100) > 140.00

**END

```

**Fig. 14**  
Output of the data vetting option of the ENERGY program

```

./COOL
***** JOB CONTROL ROUTINE FOR PROGRAM COOL

PLEASE IGNORE SYSTEM MESSAGES:[BREAK],[PROCEED]SILENCE

FOR WHAT PURPOSE HAVE YOU ENTERED THIS ROUTINE?

ENTER I TO INPUT DATA
ENTER P TO PRINT OUT DATA
ENTER C TO RUN A FULL DATA CHECK PROCEDURE
ENTER R TO RUN THE PROGRAM FROM THE TERMINAL
ENTER B TO SUBMIT A BATCH RUN
ENTER U TO UPDATE COOL DATA FILE TO ENERGY DATA FILE
ENTER E TO EXIT AND RETURN TO MONITOR LEVEL

>B

Note: If the response E is given to any further questions in this routine
the user will be able to start the routine again.

INPUT DATA FILE NAME> COOL2.TST

SYNOPSIS OF DATA FILE (Y OR N)? N

DO YOU WISH TO ALLOW VALUES OUTSIDE NORMAL RANGES (Y OR N)? Y
DO YOU WISH TO SUPPRESS ERROR MESSAGES IN PRINT-OUT(Y OR N)? Y
DO YOU WANT A NIGHT-TIME RUN (Y OR N)?Y

WHERE WOULD YOU LIKE YOUR OUTPUT?
ENTER L FOR LINE-PRINTER
ENTER D FOR DISK
ENTER B FOR BOTH
>L

NIGHT BATCH RUN OF PROGRAM COOL SUBMITTED
INPUT DATA FILENAME: COOL2.TST

ENTRIES IN THE INPUT QUEUE UNDER YOUR PPN ARE AS FOLLOWS:

.INPUT QUEUE:
PTY PPN JOB SEQ Prio NAME TIME CORE AFTER
17210,52 COOL2 143 62 C.G R.AISH 00:30:00 43 +07:49

TOTAL (includes all jobs)
INP: 2 jobs; 00:31:00 sec. run time

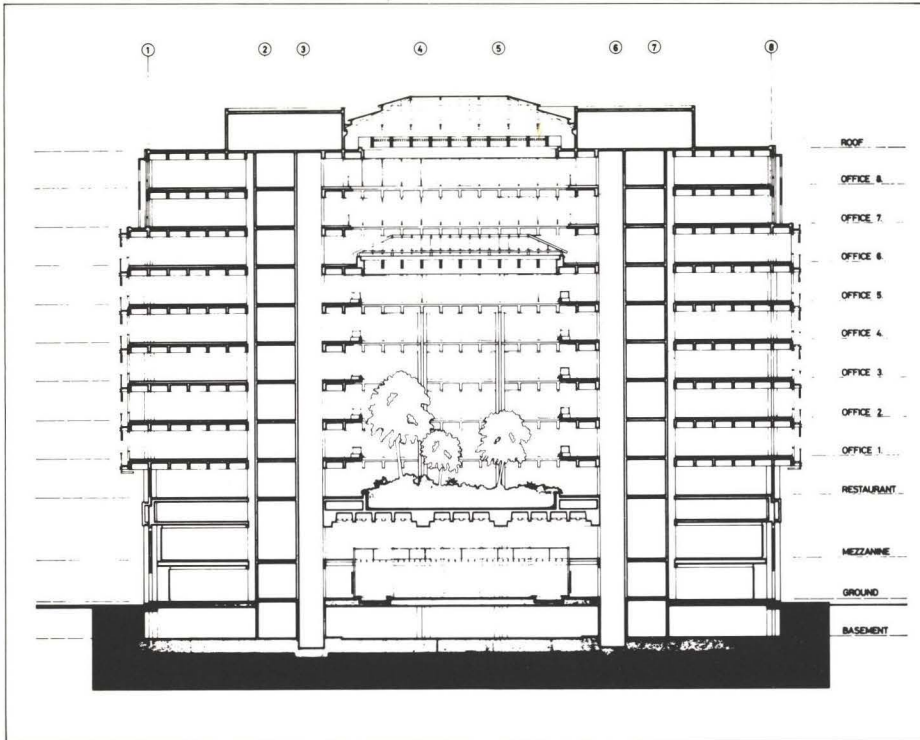
.MIC EXIT

```

**Fig. 15**  
Using the job control routine to submit a night batch run of the COOL program

**Table 1 : Data modules for the THERMAL suite**

HEAT	COOL	ENERGY
General	General	General
	Climatic Temperatures	Non Standard Days
	Options	Options
External Surfaces	External Surfaces	External Surfaces
Internal Surfaces	Internal Surfaces	Internal Surfaces
Glazing Types	Glazing Types	Glazing Types
Room	Room	Room
	Zones	Zones
		Systems



**Fig. 16**  
Office building, Dammam, Saudi Arabia

Fig. 13 shows how the user can progress through the THERMAL suite using the UPDATE program to move data from program to program. This enables the user to design the building geometry once and then add the necessary extra data as he progresses to the more complex programs.

Data vetting is an extremely important aspect of any program system which is to be used by a large group of users. Fig. 14 illustrates the form of one of the input data modules for the ENERGY program as it has been output to a user with the appropriate warning messages.

After vetting the input data, the user can proceed, for example, to submit a batch job so that his input file can be run with the specified program.

Fig. 15 shows the dialogue between a user and the interactive job control routine for the COOL program. The facilities illustrated here

are common to all DEC 10 Building Services Programs.

The user types/COOL to initiate the routine

He selects the 'B' option to submit a batch run of the programs.

The user identifies the input data file to be used.

The program checks that this file exists and that it is an input file for COOL program.

The user can select a synopsis of this input data file, to allow values out of range or to suppress error messages in the printout.

The user has the option of either a more expensive but immediate day batch run or a less expensive night batch run of the COOL program.

The user can select whether his output will be printed or stored on disk or both.

The program checks that there is 'logged in' capacity on the user's disk area for all intermediate files and 'logged out' capacity for all output files for the number of rooms and the output options which the user has requested in his input file.

Finally the job control routine shows the entry in the batch queue so that the user can check that everything is correct.

### A typical application

The General Organization of Social Insurance Saudi Arabia commissioned Ove Arup and Partners Saudi Arabia Ltd. in October 1977 to design a building on Amir Nasir Street in Dammam.

The building consists of a basement car park, two floors of shops, a restaurant and eight floors of offices (See Fig. 16).

The offices and restaurant are planned around an internal naturally-lit courtyard with planting at the lower level. The offices look into this courtyard and the restaurant has direct access to the planted area so that people can enjoy the cool shaded environment as a contrast to the hot dusty atmosphere of Dammam.

The building is air-conditioned and is shaded on the outside by timber screens which echo some of the indigenous forms of architecture of the Middle East.

The THERMAL suite and other building services programs were used in the design of this building.

COOL was used to size the fan coil air-conditioning units in each room and to size the central refrigeration plant.

ENERGY was used to determine the total annual energy consumption for the building. To achieve this a weather tape for nearby Dhahran was used and the data on the room and window geometries was transferred from the input data files used for the COOL program.

The sun path program was used to design the shading for the dome over the central courtyard and the timber screens on the sides of the building. The plotter generated the sun path diagrams and a shading protractor. Using the protractor the engineer established the ability of the shading devices to obscure the direct sunlight.

PIPEI was used to design the water distribution system from the central plant to the fan coil units in each room.

CADRAW, the computer-aided drawing package, was used extensively to prepare the production drawings.

### Conclusions

This library of Building Services programs has provided our building services engineers with a range of powerful design and analysis aids.

The user interface utilizes a simple interactive questionnaire technique and a very straightforward editor, with which most of our engineers are familiar. After initial training we have found that most users can prepare data and operate the programs with no supervision.

The level of use of the programs is increasing with, for example, three runs of the COOL program and one run of the ENERGY program a week. Eight other organizations external to the practice are also using these programs.

# Ebury Street Development

Maurice Smith

**Architect:**  
**Ted Levy Benjamin & Partners**

The brief was to design a development which could accommodate 96 luxury flats with shop units at ground floor level and an underground car park.

The planners stipulated that the height, scale and module of the building should be in keeping with the surrounding properties in Ebury Street. To achieve the numbers of flats and to stay within the height restriction, the building was stepped above roof level. This gave an elevation which blended with the existing buildings which surround the development.

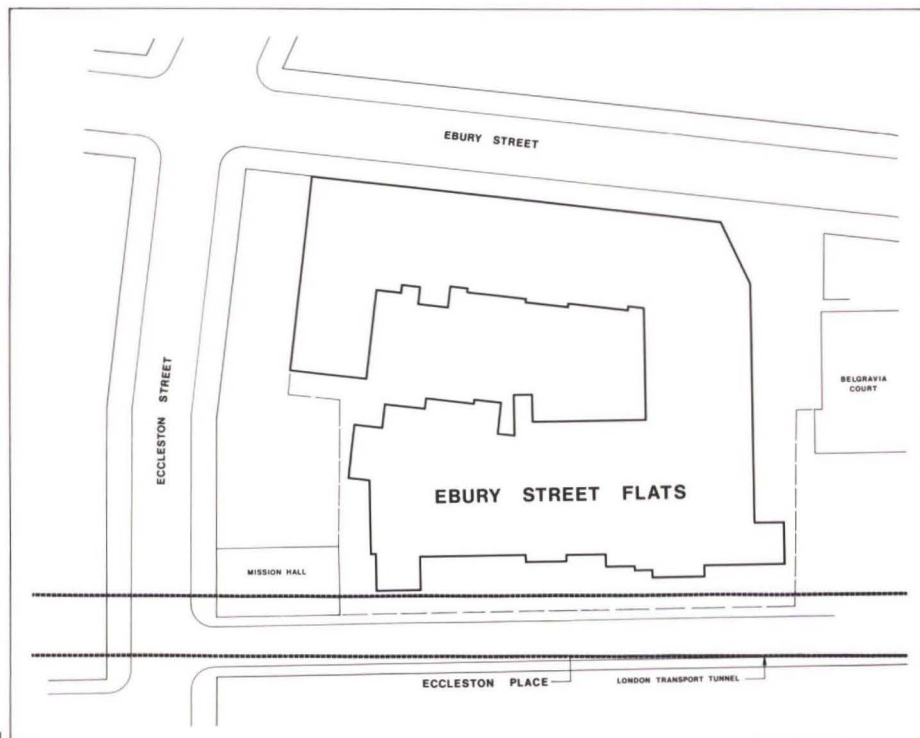
The major structural problem was to ensure that noise and vibration that was generated from the London Transport Underground line was not transmitted through the foundations into the structure.

In order to overcome this problem the super-structure is separated from the substructure at first floor level. The transition slab at this level, which carries the structure for the flats above, is supported on bearings which sit on column heads directly under the transition slab. The structure is of reinforced concrete, with piled foundations, and a mansard roof of structural steel and timber.

The building contract commenced in February 1977 and was completed in mid-May 1979.

## Credits

*Client:*  
MEPC  
*Architect:*  
Ted Levy Benjamin & Partners  
*Quantity surveyor:*  
Gardiner and Theobald  
*Main contractor:*  
Sir Robert McAlpine



**Ebury Street flats**  
Site plan and aspects of the development  
(Photos: Ove Arup & Partners)





# Structural Steel Design Awards 1980

Two projects with which Ove Arup and Partners have been associated have featured in the above awards which are sponsored by The British Steel Corporation and The British Constructional Steelwork Association Ltd. These are:

(1) Assembly and Pretest Facility, Cummins Engine Factory, Shotts, Lanarkshire which has won an Award

and

(2) South Poplar Health Centre which was specially commended.

(In all there were four awards and four commendations).

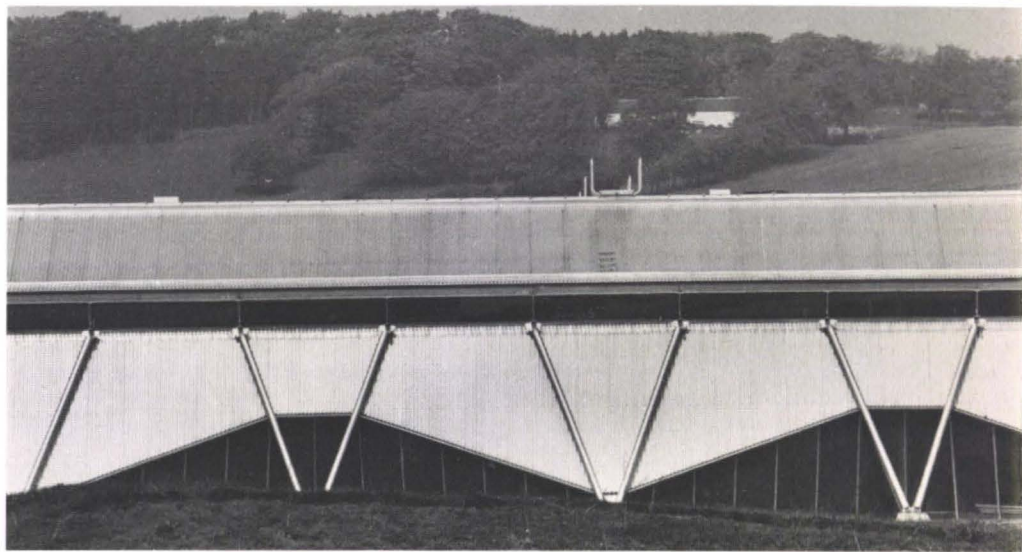


1

2



3



**Figs. 1-2  
Cummins Engine Factory**

*Client:*  
Cummins Engine Company Ltd.  
*Architects:*  
Ahrends Burton & Koralek  
*Steelwork Contractor:*  
Redpath Engineering Ltd.  
(Photos : Ove Arup & Partners)

**Figs. 3-4  
South Poplar Health Centre**

*Client:*  
City and East London Area Health Authority  
*Architects:*  
Derek Stow & Partners  
*Steelwork Contractor:*  
J. H. Slade Ltd.  
(Photos : Henk Snoek)

4





