

# THE ARUP JOURNAL

4/1996



ARUP

# THE ARUP JOURNAL

Vol. 31 No. 4  
4/1996

Editor:  
David J. Brown

Published by  
Ove Arup Partnership  
13 Fitzroy Street  
London W1P 6BQ

Art Editor:  
Desmond Wyeth FCSD

Deputy Editor:  
Hélène Murphy

Editorial:

Tel: +44 (0) 171 636 1531 Tel: +44 (0) 171 465 3828  
Fax: +44 (0) 171 580 3924 Fax: +44 (0) 171 465 3716

## Phoenix Central Library

Rob Bolin  
Nancy Hamilton

3



The City of Phoenix, Arizona, wanted a 'library for the 21st century', to accommodate fully the needs of information technology as well as traditional printed sources. Ove Arup & Partners California carried out the building engineering design for this distinctive landmark building, which meets its complex brief within a tightly-controlled budget.

## The future of intelligent buildings

Anne-Sophie Grandguillaume  
Jim Read  
Bill Southwood

8

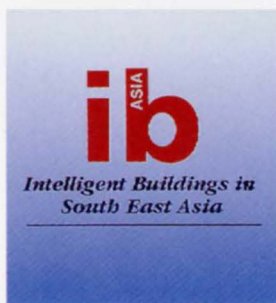

Arup Communications formed part of a joint venture to carry out a research project in South East Asia to identify characteristics of 'building intelligence'. This article summarises its findings, defining levels of computer-integration in buildings, and analysing the benefits and costs of integration.

## Revenue forecasting for transport projects

Aidan Eaglestone  
Ed Humphreys  
Dave Thompson

11



Transport projects tend to carry significant risk, which in turn leads to funding difficulties. Arups' experience has shown how essential expert patronage forecasting and economic/financial evaluation are to delivering the funding that will get transport projects built. This article summarises arguments for the use of these methodologies, and discusses their use on projects in Thailand, Singapore, and the UK.

## Rehabilitation of Anderson Road Quarries, Hong Kong

Paul Fowler

15

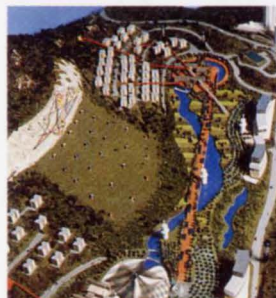

Quarrying on the hillside overlooking East Kowloon has left a major landscape scar. Ove Arup & Partners were commissioned to carry out a comprehensive study for its rehabilitation, embracing quarry development planning and land formation, engineering design, infrastructure assessment, and traffic impact. Work on implementing the study's proposals begins in January 1997.

## San Miguel Breweries in China and Hong Kong

Mike Dunk *et al*

17



In 1994 San Miguel commissioned two new breweries for fast-track completion in Baoding, China, and the New Territories, Hong Kong. Arups have provided co-ordinated design services for the former - plus full design responsibility for some areas of the project - and project management and construction management in addition to full design and design co-ordination for the latter. This article describes the completely different challenges for two Arup project teams in Hong Kong, supported by colleagues in London, Manila, and Nottingham.

# Phoenix Central Library

Rob Bolin Nancy Hamilton

## Introduction

Phoenix, Arizona, has been one of the United States' fastest-growing cities over the last decade. This growth has made it aware of the need to expand its cultural and community base, which in turn triggered plans for a new state-of-the-art cultural/arts centre to revitalise a declining downtown area. Several commissions are currently in design or have recently been completed, notably the Phoenix Art Museum, designed by New York architects Tod Williams and Billie Tsien, and Richard Meier's New Courthouse Building, for which Arups in New York has a critical role in the design of the façades and atrium.

The first new civic building to be completed was Phoenix Central Library, designed by architect Will Bruder in collaboration with DWL Architects. Bruder knew of Arups by general repute, and discovered virtually by chance that the firm had offices in California. He immediately made contact and, after a number of meetings and a successful interview, the project and the relationship were born. Arups played a major role in the realisation of both Bruder's and the City's visions for a 'Library for the 21st century'.

Will Bruder is an architect trained as a sculptor, with a studio in the desert just outside Phoenix. Having recently completed a series of innovative branch libraries for the City, he was ideally placed to design the new Central Library. The Arup team quickly realised that he and his collaborator Wendell Burnette believed in teamwork, bringing to the project great talent for investigating, examining, making decisions, and re-examining, all very quickly to meet not only schedules and budgets, but also ideals. This resulted in a cost-effective and, above all, a truly integrated building of great pragmatism and poetry.

## The brief

Having outgrown their existing library, the City was looking for new premises in which all of its collections could be available, with room to expand for the 21st century. Technology played an important role in their vision, which realised that the library of the future will integrate information technology with traditional printed sources. Offices for the librarians, special collections spaces, a public reading room, and children's rooms were also part of the brief for the library as a space the public would enjoy. Initially a 240 000ft<sup>2</sup> (22 300m<sup>2</sup>) building was called for, with a \$28M (£20M) budget. The design team's examination of the brief discerned inefficiencies in the existing library design and, through discussions and agreement with library staff, were able to provide a total of 280 000ft<sup>2</sup> (26 000m<sup>2</sup>) for the original \$28M, or \$100/ft<sup>2</sup>.

The issue of energy efficiency was critical. The brief underlined the need to design for the extreme desert climate conditions of Phoenix, with summer daytime temperatures reaching 110°F to 120°F (43°C to 49°C), and that maintenance and

1. The polished stainless steel skin above the entrance resembles a canyon cutting through a Monument Valley mesa: an example of Bruder's use of 'functional metaphors'.



operating budgets, as with many cities, are under strict review and are almost always reduced. For the building to be successful throughout its life, it needed to be efficiently maintained and have low energy consumption. The project also had site challenges: a quarter of its area extends out over the I-10 freeway, where the previous design of the freeway tunnel had envisaged supporting a much lighter building than a library.

The building had to be designed for future expansion, and still give flexibility for change in the meantime. It was important to avoid errors of past public building design, when structures served single functions and had limited growth or change potential, resulting in the need for early replacement or major renovation.

2. North elevation and entrance.



## The solution

Will Bruder believes in total team collaboration, and in the early design phases, not a single idea or suggestion passed unexamined. Many alternatives were considered and rejected before the final solution was agreed. The critical issue was always to provide a building that mirrored and respected the desert environment. One early strategy was to emulate the traditional Southwestern adobe house, using heavy, dense concrete walls that allowed little light to enter and provided a time lag that moved heat gains from the harsh, daytime sun to later in the day. But it was agreed that the users might not have been happy with that solution.

Many of Bruder's concepts were based on his use of 'functional metaphors'. Reflecting Arizona's unique natural beauty, the building image was to resemble a Monument Valley mesa. The polished stainless steel skin above the entrances looks like a canyon cutting through the mesa, and the façade's corrugated copper panels recall the grain silos, barns, and railroad cars common to local history (Figs 1 & 2).

The key to the solution lay in the organisation of the library floor plan. Early schemes gravitated to the typical central core, with limited glazing on all perimeters, and mechanical equipment on the roof. However, such schemes proved cost-ineffective, energy-inefficient, and did not give the flexibility that a 'Library for the 21st century' needed. The breakthrough came during a team design meeting when a plan emerged for a service zone on each side of a 'warehouse for books'. The western metaphor was the saddlebag, where a cowboy keeps everything he needs at his side (his support space), while he rides his horse. The 'saddlebags' for the library hold the fixed service functions, like service elevators, exit stairs, and rest rooms, as well as spaces for all of the mechanical and electrical rooms and the lateral framing for the structure (Fig 3).

The 'saddlebags' embrace the east and west façades, and combined with heavyweight, dense concrete walls, reduce heat gains.

More importantly though, glazing on the north and south walls open the library to views of Phoenix, bringing in the necessary daylight for reading. Again addressing the need to minimise heat gains, the glazing on the south side incorporates external movable aluminum louvres to mask direct sun, while maintaining views and natural daylight (Fig 4). The north façade has external vertical shade sails to avoid northeast and northwest summer solar heat gains reaching the space (Fig 5).

The concept also allowed for floor-by-floor air-conditioning units, which minimised cost through limited duct distribution, and increased library flexibility. The 'saddlebags' also kept lateral structural support to the building perimeter where it is most effective, leaving relatively open areas in the interior where changes can easily be made.

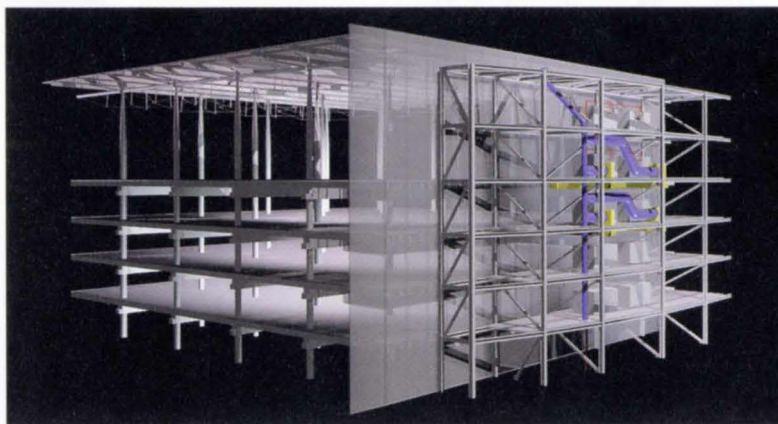

3. Structural form showing braced frame 'saddlebag'.

4. Aluminium louvres at roof level on the south façade.



5. Vertical shade sails on the north façade.

Another critical issue was the desire to place the main reading room and non-fiction collection at the top of the building (level 5), which would provide the best views and ensure that users experience the library as a whole as they are drawn up through its central full-height atrium in glass elevators or onto the grand staircase (Fig 6). The reading room created the opportunity for a double-height space topped by a lightweight roof system (Fig 7).

#### Building engineering systems integration

Working on such a tight budget, a rigorous services distribution logic was critical. The design team could not rely on the common solution of a dropped ceiling with services in a free-for-all below a structural zone. Budget and aesthetics dictated that the entire architecture, structure, and services be integrated.

The floor-to-floor heights needed to be minimised because of budgetary limitations and yet a sense of public graciousness was desired, which led to the use of structure as architectural finish. A very flexible, modular, precast concrete box was created and organised on a 32ft 8in (9.96m) square grid, a finely tuned dimension based on a library stack, with a specially-designed overhead light giving constant illumination down to the base of the shelf. The module was structurally efficient and repetitive, and by co-ordinating it with the stack layout, the design greatly increased stack capacity compared to a standard 30ft (9.14m) structural module. The precast floor framing is a double-T system over dropped girders. The ribs on the Ts are 30in (760mm) deep, which provides the

necessary structural depth for heavy library loads as well as a service zone. The Ts span east-west on the grid lines across the building from saddlebag to saddlebag, whilst the girders similarly span north-south parallel to the saddlebags. Along the building's perimeter length, two precast concrete load-bearing walls separate the saddlebags from the main library space, doing triple duty by providing architectural finish, thermal mass, and lateral structural stability in the longitudinal direction.

To allow for services distribution in the space between the Ts, the precast girders were lowered, with their tops at the bottom of the Ts. The services run between the T-spaces, organised into horizontal zones of HVAC, lights, sprinklers, power, and data (Fig 8). The main building services distribution from the saddlebag mechanical and electrical rooms run parallel to the saddlebags, just inside the perimeter, and are integrated in what are known as the 'power bellies', two of which occur on every floor, except level five. The main HVAC supply and return ducts are in these zones as well as the main electrical power, data, and telephone cabling, plus fire sprinkler trunklines.

In the reading room at the top of the building, a cable roof covers the double-height space. The design recognised that the need for air-conditioning here should not mask the aesthetic simplicity of the roof's structural design nor the concept of the tapered 'candlestick' columns. To avoid distributing ducts at high levels, an integrated raised floor system was provided to distribute conditioned air, communications, and electrical power.

6.  
Looking down  
the 'crystal canyon'  
central atrium.



7. Left: Book stacks and roof structure in fifth level reading room.

8.  
General view showing  
precast girders and services  
between double-T floor units.



### Cable truss roof

The library's crowning glory is this fifth floor reading room with its 'tensegrity' cable roof and views to the Phoenix skyline.

A network of diagonal interlocking cable trusses is supported vertically on tapered precast concrete 'candlestick' columns on the building's primary grid, and anchored at two edges by the lateral steel trusses of the saddlebags. Above the cable trusses is a system of tubular steel purlins with 7.5in (190mm) deep metal deck, insulation, and ballast. The sides of the metal deck ribs are perforated for acoustic absorption (Fig 9).

The diagonal column-to-column cable trusses consist of an upper and lower 15/16in (23.8mm) diameter cable chord separated by two vertical 4in (100mm) diameter steel pipe struts. These are common to two intersecting trusses, and continue up above the top cable chord to support the tubular steel purlins and deck. The trusses resolve at their ends to a single node at mid-depth, the top of each 'candlestick' column, which stops short of the roof surface by 6ft (1.83m). The design of that node was of particular architectural attention; it is in the shape of an abstract 'candle flame'.

Centred directly over each column is a circular, glacial blue, translucent skylight lens with a very small clear glass hole positioned such that at the summer solstice, the sun at solar noon 'lights' the candle flames at the tops of all of the columns to celebrate the first moment of another desert summer (Fig 10). The cable truss network receives its prestress from each point where the net meets the saddlebags' lateral frames. The cable net forces are diagonal to the saddlebags, resolving the prestress and loading forces into components in the precast walls along the length of the building, and into the braced frames within the saddlebags.

### Structural system

As already noted, the main structure is essentially a precast concrete box, formed of double-T ribs east/west and inverted precast girders north/south. The latter are supported by precast

concrete columns with customised column capitals forming a structural corbel. The curving shape of the capital reflects the curvatures of the building's architectural language. Precast concrete bearing walls act as shear walls in the north-south direction. The saddlebags flanking the box have steel braced frames to provide lateral stability in the east-west direction by means of braced frames, as well as anchoring the cable roof.

Most of the building's components were precast and prefabricated off-site and assembled on site, much like Lego. After the foundation concrete was poured, the structural steel saddlebags were erected, and then a crane used to erect the precast concrete walls and floor systems between the saddlebags. Precast concrete columns, Ts, and girders were placed, floor by floor. Topping slabs were poured in place on top of the Ts to provide a continuous diaphragm, and finally the cable truss roof was installed.

Some of the library is supported over the I-10 freeway (Fig 11). During the original construction of the deck park's tunnel structure, the area over which the library now sits was identified as supporting a future office building.

9. Below: Reading room.



10. Skylight lenses over columns.

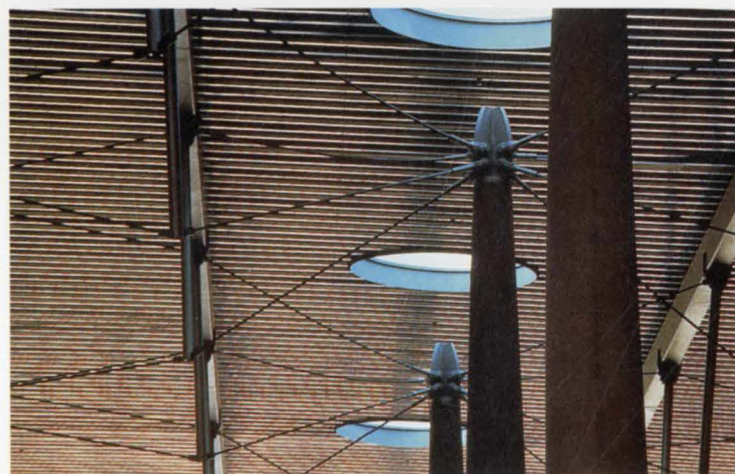



11. Library as seen atop I-10 freeway overpass.

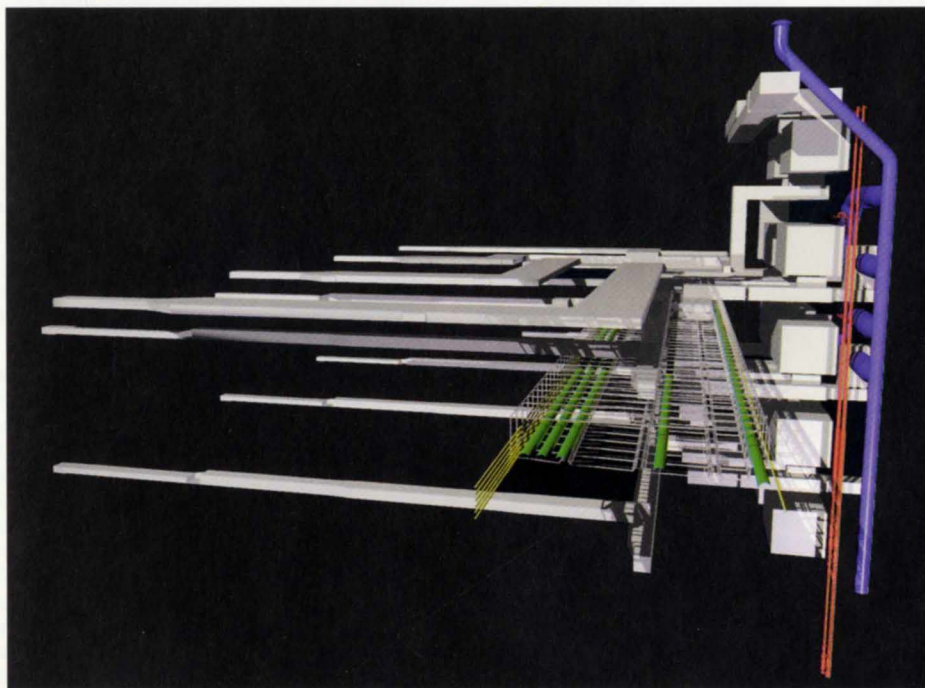

12. Air handling units and air and piping services distribution.

At that time, of course, future column grids and loading could not have been anticipated, and the deck park pedestals installed to receive future loads were not consistent with the 32ft 8in (9.96m) column grid, nor could they support five storeys of library. A series of in situ concrete grade beams were therefore used to transfer the column loads to the pedestals provided for anticipated columns. Because of the loading limitations of the tunnel structure above the freeway, the library's height over the tunnel is limited to two storeys and all elements made of lightweight concrete.

### Mechanical systems

Gas absorption chillers and boilers in the ground floor mechanical room provide chilled water and low temperature hot water to the air-handling units in the saddlebag mechanical rooms, and to each variable air volume (VAV) unit reheat coil. The lower four floors have a VAV system, with ductwork and the VAV boxes located in the structural Ts served from the floor-by-floor main ducting running in the 'power bellies'. Air distribution into the spaces is provided through specially designed perforated ceiling panels, designed and tested at the maximum and minimum flow rates to ensure adequate air distribution through the range of flow rates. The top floor was provided with a raised floor air-conditioning system utilising smoke barriers to provide the plenums, ensuring adequate flow through the diffusers at the furthest point from the air-conditioning units (Fig 12). It is worth noting that during design, the cooling and heating load calculations indicated that the building would use 10% less energy than dictated by the State authorities. A 1996 study by students from Arizona State University indicated that the predictions were being exceeded by a further 15%.

### Electrical systems

The building is serviced by two 3000A incoming supply lines from the Phoenix Power Company; the supply voltage is 480V/277V, three-phase, four wires. Power distribution is divided into east and west zones, each with two electrical risers located north and south as part of the saddlebags, which allows the cables for both feeders and branch circuit wirings to be most efficient.

Circuits serving light fixtures and receptacle outlets run inside the designated zone within the structure of the precast Ts at ceiling level as part of the overall service integration distribution. To bring power and communication wiring to each work desk, Arups developed with the architect a cable drop method, where flexible conduits snake around a tensioned aircraft cable fixed between ceiling and floor.

This provides both power and communication cables where the user wants them, as well as creating a playful sculptural gesture. On the fifth floor reading room, a raised floor accommodates the power and communication cables.

Software programmed to follow the sun's path oversees the movement of the horizontal solar louvres that reduce direct sun penetration into the building. The mirrors on the skylights above the 'crystal canyon' atrium lightwell rotate so that maximum sunlight can be directed into this space. A central computer room services both the library and the community's branch system. It also provides Internet access for local patrons.

Translucent glass divider walls between the library's public rest rooms use fibre optic cables, which appear to visitors as ever-changing colour stars.

### Summary

From the initial phone call to regular visits after completion, to library patrons excited about their new building, to realising a construction cost of \$100/ft<sup>2</sup>: this project exemplifies the building engineering philosophy of Arups in California. On a recent tour with a client around the building, the success was summed up by his reaction: 'All this for \$100/ft<sup>2</sup>!' Will Bruder is among the few architects who believe not only in the master builder concept, but the master builder who listens to his clients and collaborators and moves forward with them.

### Credits

*Client:*  
City of Phoenix, Ralph Edwards, Library Director

*Architect:*  
bruder DWL architects  
(joint venture between William P Bruder, Architect Ltd and DWL Architects and Planners)

*Structural, mechanical, electrical, public health, and acoustics engineers:*

Ove Arup & Partners Rob Bolin, Peter Budd, Larry Chambers, Jacob Chan, Donna Clandening, Nancy Hamilton, Richard Hough, Scott Hudgins, Mike Ishler, Alan Locke, Dan Urseha, Atila Zekioglu

*Consultants:*  
Professional Library Consultants and Mason Associates (library)  
Lighting Dynamics (lighting)  
Tait Solar Company (daylighting)  
Construction Consultants Southwest (cost)  
FTL/Happold (structural fabric)  
Baltes/Valentino Associates (local MEP consultants)  
Martino & Tataschiere (landscape architect)  
Hook Engineering (civil engineering)  
Dillion and Associates (code)  
Fowley Associates (graphics)

*General contractor:*  
Sundt Corp

*Illustrations:*  
1, 2, 5-11, Bill Timmerman  
3, 4, 12: Ove Arup & Partners

# The future of intelligent buildings

Anne-Sophie Grandguillaume  
Jim Read Bill Southwood



## Background and aims

The term 'intelligent building' has become familiar, perhaps over-familiar at the end of this century. What does it mean? What could, or should it mean? In 1994 Arup Communications, DEGW, and Northcroft formed a joint venture company, IB Asia Ltd, to carry out a research project in South East Asia to identify an appropriate definition of 'building intelligence' for the region. South East Asia is the perfect location to investigate the future of intelligent buildings because of the high infrastructure development and construction activity across the region. Arup Communications' particular role was to examine technology and building services trends in the region as well as be part of the total building case study and rating method team.

The intention was to identify characteristics of building intelligence and provide guidance on how they might develop in the future to best serve the needs of a rapidly changing region and the points of view of three interest groups:

- Building providers and developers
- Suppliers of information and communications technology
- Building owners and occupiers.

The relationship between these three groups is complex and often poorly understood:

- If building providers do not supply the right sort of building, it will be difficult to install technology.
- If users do not understand the building benefits provided, they will be unwilling to pay the developer a premium for intelligent space.
- Low returns will discourage technology suppliers from developing intelligent building products and services.

As in Europe, there has been much uncertainty in South East Asia about which urban centres can best support intelligent building developments, what form building intelligence might take, and which products would be needed by users. In 1991-92 DEGW and Teknibank had carried out a study of 'Intelligent building in Europe' which, in focusing away from technology, proposed a model fundamentally different from earlier concepts. The Asian study built on this model, from which the following definition was derived: 'An intelligent building provides a responsive, effective and supportive intelligent environment within which the organisation can achieve its business objectives.' The European study also proposed a technology evolution model (Fig 1), which underpins the following findings from the IB Asia study.

## Information technology (IT) and the building user

Traditionally, the technology associated with a building has been thought of as that employed in building control systems - HVAC, lighting, vertical transportation, and security. In the last decade, user IT has had an overwhelming impact on building design, and more recently the influence of technology in acoustic design and in façade and fire engineering has been making its presence felt.

The study addressed all these disciplines but concentrated on the two major areas of technology having most impact at present: building control and management systems, and the IT systems and services used by the building occupants - the user IT systems.

Buildings and IT interact in various ways:

- (1) Most visibly, there is the effect that IT is having on building users and on the traditional and emerging uses of voice, data and image communication systems in a building.
- (2) IT is also having a profound effect on the way buildings are controlled. Building management systems and energy management systems have long been computerised; the interactions between these and, for example, the telephone system are becoming more widespread.
- (3) In the last decade IT has revolutionised the way buildings are designed and constructed, particularly in energy efficiency and use of advanced materials.

The key interaction between a building and the technologies it contains is adaptability.

Most organisations that are IT-intensive have a very high rate of change - of 'churn'. Intelligent design enables the cost of moving the IT at a workplace to be reduced by at least an order of magnitude. Typical cases quote a reduction from over £400 to around £35, and the time to relocate or add voice and data services from weeks to a few minutes. These cost and time savings can justify the capital investment for the cabling needed to support IT networking equipment; it is the cabling infrastructure that will provide the adaptability to allow these investments to be paid back in a very short time.

## The future for information transmission in buildings

Every building user today is affected by information, and for the foreseeable future user demands on IT will grow significantly. So too will data traffic levels as users demand more from their networks. Businesses require a wide range of continually evolving facilities to give competitive edge, and technological change has set the pace, introducing new systems with an ever-decreasing time to market. Two trends have become apparent: the demand for ever-expanding bandwidth and the competing technologies of copper, optical fibre and 'cable-less' to meet these demands.

The copper/fibre debate has so far centred on cost. Whilst optical fibre itself is inexpensive, the connectors

and transceivers to convert between light and electricity have been prohibitively costly. The cost of the electronics is decreasing, however, and much research is going into reducing the cost and complexity of connectors. It is likely that, before the end of 1998, optical fibre will be as cheap as copper cabling.

The implications, given fibre's much greater bandwidth and immunity from electromagnetic interference, are profound.

Cable-less communications have revolutionised voice services in the public domain. In just 10 years, the advent of cellular radio telephony has spawned a new industry for person-centred communications. Within the local area of the office, the revolution has yet to make a large impact, though peripatetic staff in buildings difficult to cable are frequently served with wireless voice communications.

Data communications over radio have lagged behind, mainly due to bandwidth limitations and concerns over security and reliability.

## Building control systems

Technological advance is changing the way buildings are controlled and operated, with mechanical methods replaced by electronics and distributed intelligence. The client server architecture which took over in the user IT field in the early 1990s also induced a distributed approach to building control technology, where intelligence and processing power are as near as possible to the monitored or controlled item. All outstations are equal and control functions performed more and more at local level, with the central system performing enhanced management functions. This also makes for a potentially more resilient and robust control system, as under fault conditions many systems can perform without a central station.

The accelerating trend towards a fully integrated controls environment is currently restricted by the lack of standards. Regrettably, the open systems approach that has so revolutionised user IT has yet to make a serious impact in this area. Whilst work on establishing standards is progressing, none of them are as yet formally accepted. Building controls are in a similar position to where user IT was in the 1970s, with many major corporations using proprietary standards as a way of maintaining customer loyalty.

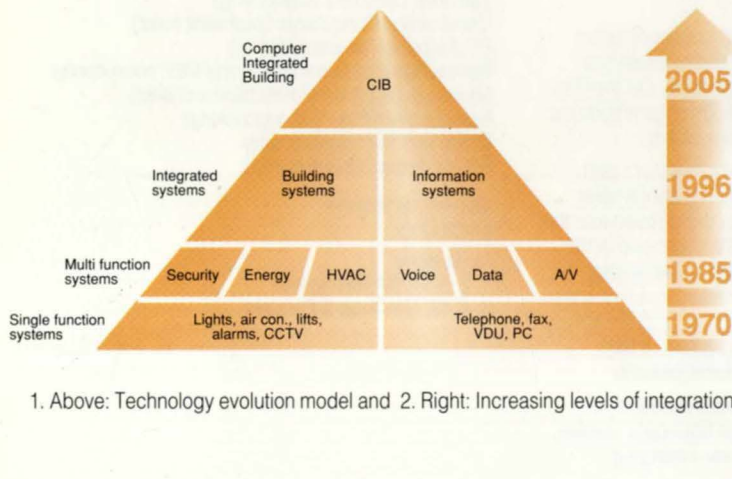

1. Above: Technology evolution model and 2. Right: Increasing levels of integration.

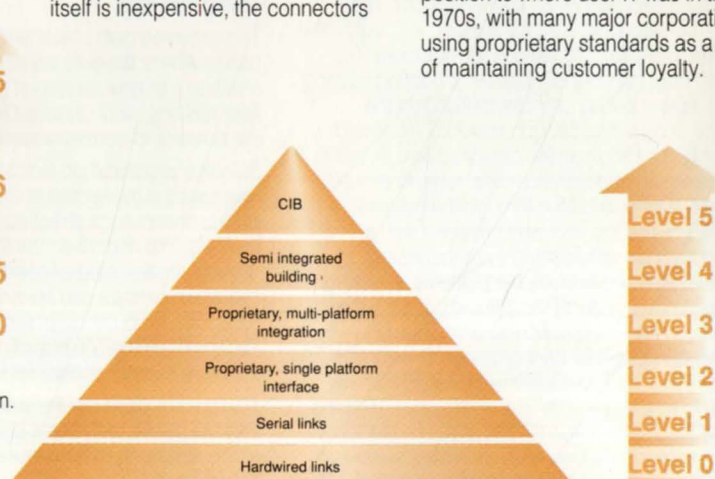



## The computer-integrated building

The fully integrated building, with all the electronic systems serving the user and the building itself combined, has been talked of for many years. There are good and bad reasons why it has never yet been achieved. Amongst the former is the valid concern that demands for reliability and security of, say, a fire alarm system may be compromised if integrated onto a common network with user IT applications and building control functions. Less justifiable has been the unwillingness by the building controls industry to adopt open systems approaches, but there are encouraging signs that this is changing with initiatives on standards such as BACnet, which defines a network protocol for inter-connection of objects and services.

## Levels of integration, advantages and drawbacks

Progress towards a fully computer-integrated building can be seen in staged form (Fig 2). The base reference level 0 with hard-wired links represents the original way of providing building controls. Many systems were hydraulic and the sheer volume of pipes and cable limited the number of devices that could be controlled in this way. Surprisingly, many of these systems are still in use today. Levels 1 to 4 illustrate an increasing degree of integration:

- Level 1 indicates limited information sharing between closed system components.
- Level 2 states that interface is possible, but only between systems of the same manufacturer.
- Level 3 shows that interface is possible between different manufacturers. However, this is often attained only by using customised gateways.
- Level 4 represents examples of limited integration with user IT systems, eg telephone control of lighting.

Progress towards the fully integrated building of level 5 has been slow for several reasons:

- Industry fragmentation means that different components are provided by different kinds of suppliers.
- Lack of standards and the motivation to work towards them has meant that most systems are proprietary.

• Integration therefore requires gateways which multiply as the number of systems to be integrated increases.

• The perception persists in the minds of owners and occupiers that previous attempts at integration have produced unnecessarily complex systems which did not provide value for money.

Some buildings aspire to the level 5 criteria, but research on the IB Asia project indicates that worldwide these are few in number. Those that do exist have demonstrated that integration of building, access, security, and IT functions allow new procedures to be adopted which improve the effectiveness of tenant organisations. Fig 3 shows how this integration can be achieved through a data network and management platform conforming to open systems standards.

## Benefits and costs of integration

We have seen that integration has been largely accomplished in the user IT arena. Telephone systems and data networks have benefited from standardisation achieved during the 1980s, resulting in an explosion of networking applications in the 1990s. Such almost universal standardisation has not yet happened in building controls, and integration can thus only be achieved today with considerable technical effort, at high cost. Some examples of benefits and savings to be expected from integrating building control systems and user IT systems, and which will ultimately justify the investment in standardisation, are as follows:

- As structured cabling has reduced the cost of churn in relocating the users' voice and data terminals, so integration of building controls and adoption of a standard cabling infrastructure for these different systems would reduce the cost of reconfiguring lighting and air-conditioning controls after a move.
- Whilst integration implies greater complexity in the systems themselves, the user interface should be standardised and thus become friendlier. This will reduce the need for highly skilled staff to carry out the relatively mundane work associated with additions, moves, and changes.

4. Wave Tower, Bangkok, planned to achieve level 5 integration.



3. Technology integration model.

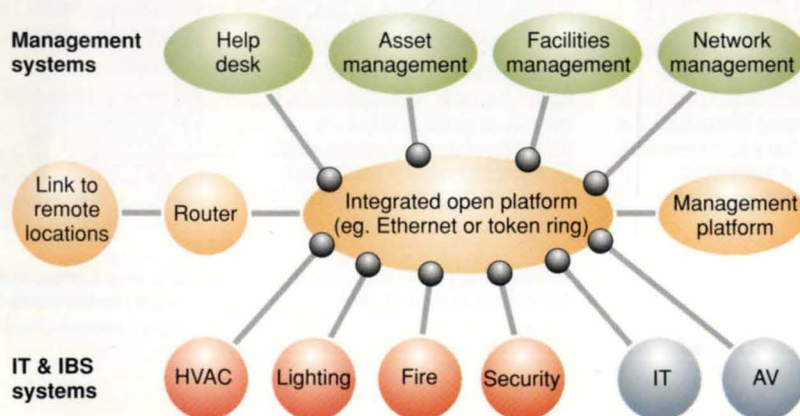

- If properly presented, information on running costs of buildings should enable these to be reduced. This is likely to become increasingly attractive to tenants (who want value for money) as well as landlords, who should find it easier to let the building.
- A help desk facility designed to meet users' needs can be more effectively provided with an integrated building.
- Database integration will result in unification of the system. Updating information on a particular user will require only one action, whereas separate entries would have to be created and maintained for IT, personnel, e-mail, and security, if database integration is not employed.
- Integrating access control systems with building management and workplace environment systems will, for example, allow monitoring of staff movement and control local lighting and temperature.

- Integrating asset databases with security procedures can be used for conference room management to co-ordinate presentation equipment with location and to administer guest security.
- Integrating information databases with office data networks and telephone systems will change the telephone's role from a stand-alone instrument to an integrated application on a personal computer.
- In the longer term, because of modular construction techniques and unified technology standards, an integrated building should be easier and more economical to upgrade than its predecessor.

Given the range of buildings and different kinds of services, it is impossible to be definitive about the additional cost of integration. However, a model produced for the study, based on a 70 000 m<sup>2</sup>, 20-storey building, gives some interesting results: full integration appears to add about 60% to the cost of standard building controls. These in turn may represent around 5% of the cost of the finished building, implying that integration adds around 3% to the overall cost.

Achieving a level 5 building today requires dedication and commitment from its owner. Much of the cost lies in developing customised software to interface the stand-alone systems illustrated in Fig 3.

There is a considerable premium to be paid for this until the industry develops and markets a range of off-the-shelf products.

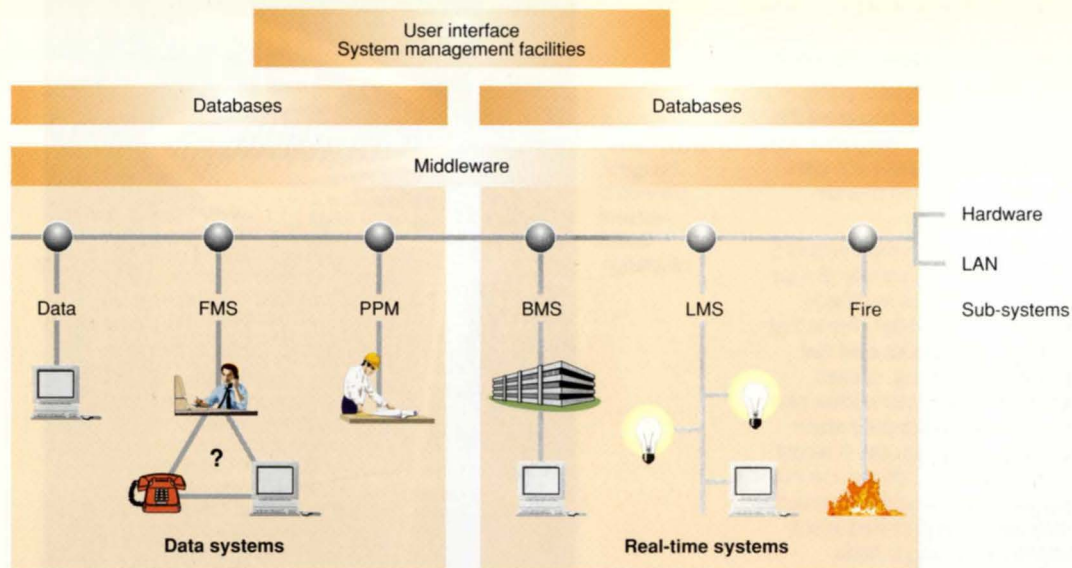

### Implementing an integrated system

The very complexity of building management systems, both in their design and operation, has been one of the main reasons why integration has so far been slow. The IB Asia study highlighted several conditions that must be met before integration can be achieved:

- Agreement will have to be reached on the use of interface standards. There are encouraging signs, with over 2000 companies currently developing 'LonMark' products which will be designed to communicate effectively. In the USA, ASHRAE is developing standards based on the Echelon chip at field level and the BACnet standard at the network interface level. It is also likely that the next generation of Intel processors and PC chip sets will be able to integrate with Echelon protocols.

- Transmission media will become more standardised. It is not obvious that the solution used for business communications - radially-wired copper and optical fibre cable - is appropriate for building controls in which a busbar appears likely to be more economical. Nonetheless there is evidence that controls are being implemented using structured cabling schemes first designed for user IT. Various other transmission media are possible, including infrared, radio transmission, and mains-borne communications.

- Should a single protocol like Echelon become pre-eminent it will, like MS-DOS, become a *de facto* standard, resulting in the market opening up to competition, prices falling, and universal acceptance.

- To achieve an integrated solution, different ways of designing and procuring building technology are likely to be necessary. Engineers, consultants, and manufacturers from both the controls and IT industries will need to form partnerships. An integration project must be led by individuals or organisations that understand the technical complexity of the systems being integrated. The leaders will also have to understand the way in which a building is designed, procured, constructed and used.

- The challenge of integrating the different packages and defining clearly the interfaces and responsibilities is starting to be faced today, and is likely to be much nearer resolution by the end of the decade. Fig 5 illustrates a system architecture for the computer-integrated building. The greatest challenge lies in creating a unified database and management functions that will ultimately control the data and real time systems.

### Findings

The key to the intelligent building is adaptability - adaptability in the face of political, economic, commercial, and technological change. The technologies, however, have the unique distinction of being not only one of the drivers of change, but also - potentially - the source of some of the solutions. A truly intelligent building uses technologies to serve, not dominate. This approach is profoundly different from the early days, when the most 'intelligent' building was the one that employed the most innovative technology. 'Innovative' soon became 'complicated', producing buildings difficult to manage and technology impossible to control.

Whilst technologies tend to be common across continents and regions, the drivers for change can be very different. Having come later to the intelligent building debate, South East Asia has the opportunity to build on the experience of using technology in Europe, North America and Japan. If applied sensibly the results could be highly successful.

There is also the opportunity to match the building technologies to the culture and climate of the countries where they are located. Differences between South East Asian working practices and other regions - and indeed between countries in the region - call for innovative approaches to using technology to support work practices.

This challenge does call for a more integrated approach to the design and operation of buildings. Greater integration of the technologies used in, for example, façades, mechanical systems, fire engineering, acoustics, and lighting control, requires all professions to be more aware of the work of their colleagues. The effort required will potentially be repaid many times over in buildings that are more effective to work in, offer better value for money, and can adapt easily to change.

### Conclusion

The IB Asia study ran from January 1995 to March 1996, funded by 11 sponsor organisations throughout the region, mainly in the property and communications technology sectors. Building case studies were carried out for 11 cities in nine countries: Australia, Hong Kong, Indonesia, Japan, Malaysia, the Philippines, Singapore, South Korea and Thailand. Three sponsor workshops were held, the first in Singapore during March 1995, then Kuala Lumpur in July, and finally Hong Kong in October. A 440-page report documenting the findings and trends was issued, after which three of the sponsors asked IB Asia to play a leading part in promotional conferences. These took place during April and May 1996 in Manila, Singapore and Sydney with around 250 attending each event.

A 46-page Executive Summary of the study was recently published in conjunction with the European Intelligent Building Group.

### Credits

**Sponsors:**  
 Australian Department of Administrative Services (Australia)  
 First Pacific Group of Companies (Philippines)  
 Jurong Town Corporation (Singapore)  
 Marlin Land (Hong Kong)  
 NTT (Japan)  
 Olivetti (Italy)  
 Technology Parks (Singapore)  
 Telekom Malaysia (Malaysia)  
 Samsung (South Korea)  
 Singapore Science Parks (Singapore)  
 Steelcase Australia (Australia)

**IB Asia Research and Coordination-Team:**  
 Ove Arup & Partners  
 Anne-Sophie Grandguillaume, Jim Read, Bill Southwood, Priscilla Tang  
 DEGW International Consulting Ltd  
 Northcroft

**Technical Contributions:**  
 Ove Arup & Partners  
 Paula Beever (Arup Fire), Paul Malpas (Arup Acoustics), David Powell (Controls & Commissioning), Alan Rowell, Chris Twinn (BG6), Jonathan Sakula (Arup Facade Engineering)

**Illustrations**  
 1-3, 5: Arup Communications  
 4: Wave Developments Ltd  
 6: Hijias Kasturi Architects



6. Telekom Malaysia HQ, Kuala Lumpur, planned to achieve level 5 integration.

# Revenue forecasting for transport projects

Aidan Eaglestone Ed Humphreys Dave Thompson

## Introduction

Forecasting revenue for transport schemes has always been important, and its importance has grown with increased public expenditure controls in many countries. There is less willingness now to finance transport infrastructure from tax revenue or government borrowing, and growing pressure to explore private finance. Transport planners in Arups have tackled a huge range of revenue forecasting work, and the network of Arup planning and transport groups are constantly facing new challenges in this area.

Why are transport projects more problematic than projects in other sectors, where it is generally much easier to mobilise finance?

Fundamentally, they tend to carry significant risk, because:

- Transport is a highly political subject which affects people's lives directly; this exacerbates uncertainty about whether projects will indeed go ahead.
- Transport projects involve significant up-front expenditure on infrastructure and equipment with limited potential for redeployment; this makes cash flow streams in the early years of a concession hugely important.
- Altering the scale of operation is often expensive: it can be difficult to alter the capacity of a transport system if projected demand levels are not realised.
- Demand for transport services is responsive to socio-economic conditions which are notoriously difficult to forecast, particularly for schemes with long lives. Revenue streams are therefore highly uncertain, particularly for public transport schemes.

Such risk often leads to funding difficulties. Funding agencies require expert economic/financial analysis of the performance of projects they are considering financing.

This analysis must give confidence in the patronage and revenue forecasts as it is these, and not primarily the cost estimates, which are difficult to forecast well and which are fundamental to financial viability.

For transport projects, expert patronage forecasting and economic/financial evaluation of schemes are crucial to delivering the funding that will eventually get them built; patronage forecasting is also essential for determining capacity requirements that form the basis of the design of transport projects. Ove Arup & Partners is increasingly becoming involved in these aspects of project planning and evaluation.

This article discusses some of the most important issues arising from these studies and looks at what has been achieved, using three recent commissions as the main examples.

There are many others, including the Isle of Skye crossing, Leeds Supertram, LUL Piccadilly Line extension, and China toll roads.

## How transport projects are financed

Transport projects can be financed by grant or loan. If by grant, there may or may not be a requirement for a specific revenue stream. If from a loan, it has to be paid back out of revenue from users, directly or indirectly via shadow tolls, or from spin-off, usually new development.

In the UK, most road schemes have traditionally been state-funded: motorways and trunk roads through central government, and local roads by local authorities - although, of course, this has relied on capital allocation from the Department of Transport (DoT). Government funding comes in many forms, of which the best known is probably Transport Supplementary Grant.

Public transport schemes are financed either by the operators as commercial ventures or with infrastructure grants, the amount of which has varied depending on government policy towards public transport investment.

The trend in the UK and in many other countries is now towards

public/private sector partnerships in transport funding. One long-established example of this is Planning Obligations involving a legal agreement between a developer and local authority; the private sector contributes towards funding the highway improvements associated with a planning application. Arup Transportation has many years' experience of advising developers and local authorities on all aspects of these agreements. In principle, there is no reason why Planning Obligations cannot be extended to a wider range of transport provision. In recent years, for example, commuted payments have been arranged to assist in financing 'park & ride' and other public transport schemes.

Another UK trend is in public/private partnerships Concession Agreements. These have been entered into for road and public transport schemes, particularly since the Private Finance Initiative (PFI) was launched to encourage private in place of public sector investment, and to increase private sector management of assets.

Design, Build, Finance and Operate (DBFO) roads will be built and maintained by the private sector in return for a 'shadow toll', a payment per vehicle kilometre on the scheme from the DoT over a 30-year concession period. There is also a move towards Design, Build, Operate and Maintain (DBOM) light

rail schemes built by the private sector in return for a capital grant, with operating costs met from fares.

Other countries face similar considerations. The aspect which varies the most is the state contribution, from Thailand's very low levels to the extremely high ones in Singapore.

## The role of ridership/revenue forecasts

Just a few of the reasons for preparing such forecasts are:

- to establish the project's viability
- to support applications for private or government funding
- to establish the balance of public/private funding
- to support competitive bids by consortia for concessions
- to evaluate competitive bids in the public interest
- to audit competitive bids on behalf of lending institutions.

As well as the problems of financing transport projects discussed above, a further complication is that the benefits of many projects spread to non-users, benefits which cannot be captured by the scheme operator. Hence transport projects are often justified in cost-benefit terms but are not viable financially.

To illustrate the point, no existing metro system covers operating costs and capital charges, in full.

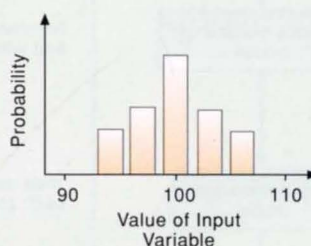

**Case A:**  
Moderate level of uncertainty  
Histogram used to define probability distribution

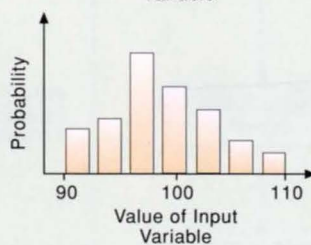

**Case B:**  
Increased level of uncertainty  
Histogram used again but probability distribution modified to reflect wider range of possible outcomes

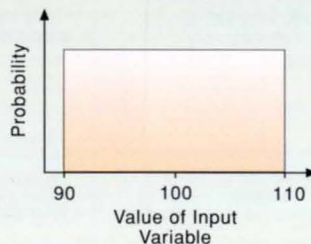

**Case C:**  
High level of uncertainty  
Rectangular or Uniform probability distribution with a wide range of outcomes with equal probability

1.  
Cases A, B & C show examples of probability distributions that might be used in Monte Carlo simulation described on page 13.

**The forecasting process**

Many techniques can be applied to demand forecasting for transport projects, but five general stages of work apply to project assessments:

- **Surveys:** collection of data about present trip-making patterns, transport facilities available and, for more complex schemes, any land use or socio-economic factors that could influence present or future travel patterns.
- **Forecasting model development:** development of an analytical model that attempts to explain the relationship between observed travel patterns and travel facilities, and, depending on the scale of the model, the land use and socio-economic factors obtained by the survey; developing an analytical model involves model specification, estimation and/or calibration of model parameters and, lastly, validation of its performance against data not used in the calibration procedure.
- **Forecasting:** use of the model to predict travel demand and/or to evaluate proposed transport schemes; for the latter, trip-making patterns have to be forecast by predicting the planning and policy variables on which they depend. This requires scenarios to be developed describing the future of the study area.
- **Sensitivity testing/risk analysis:** testing the model's performance under different scenarios and by altering key variables to establish the reliability and reasonableness of the results; the more formal risk analysis approach assesses the degree of uncertainty associated with demand forecasting and provides decision makers with a picture of the level of uncertainty they may be facing.
- **Evaluation:** assessing the results from the analysis and recommending a plan, strategy, policy, or action; this can involve operational, financial and social cost-benefit analysis of the scheme or alternatives.

**Risk assessment**

Many assumptions about the future have to be made when forecasting transport scheme usage. All are uncertain, so it is obviously sensible to produce for clients a range of different forecasts, which can be generated in several ways. In the case of the National Road Traffic Forecasts (NRTF) for Great Britain, low and high growth forecasts are prepared on, respectively, pessimistic and optimistic assumptions about economic growth and fuel prices. In designing roads, high growth is generally used as a starting point, unless there are persuasive reasons for adopting lower standards

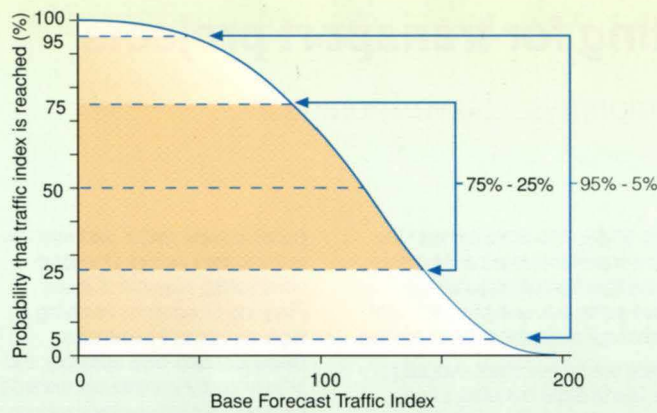

2. Typical output from Monte Carlo simulation for risk analysis.



3. An SRT train between part of the two-storey BERTS structure.

4. BERTS transportation model structure.

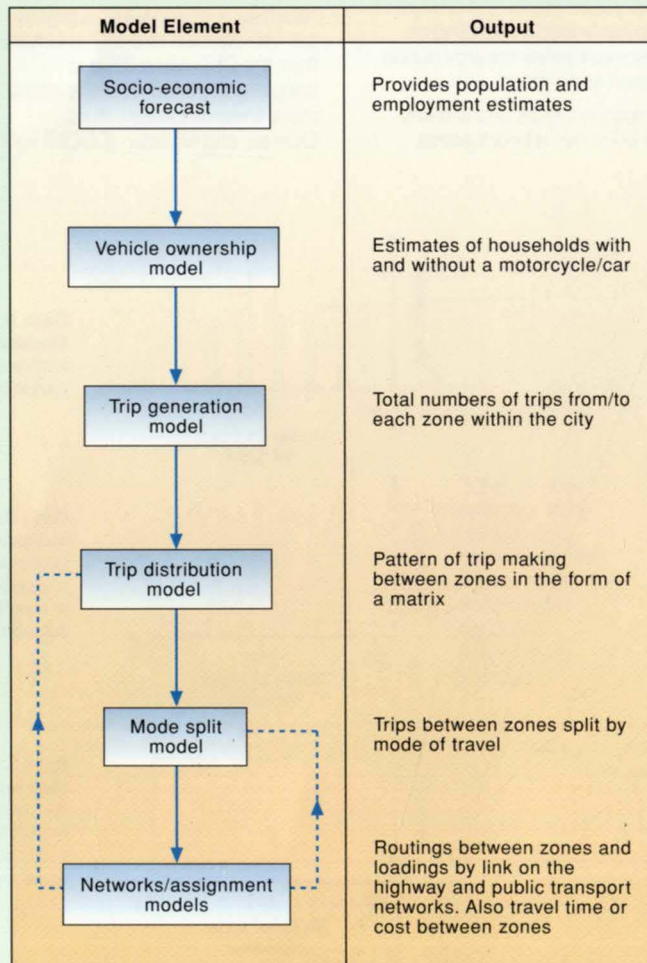

(eg environmental constraints or induced traffic considerations). This ensures that the design has adequate capacity. In public sector cost-benefit analysis, it has been common practice to use a weighted average of low and high growth net present values to determine a single value indicator of a scheme's economic performance.

Forecasting for the private sector may involve different considerations. For example, a high growth forecast might be needed to maximise revenue to win a competitive bid for a DBFO/DBOM concession, but a low growth forecast might be required by lending institutions, who naturally take a conservative view.

Sensitivity testing can be carried out in various ways. However, a structured approach can save time and money, and be less confusing to clients. Scenario Analysis, a technique used by planners in the USA, is similar to the NRTF low-high growth projection, though a wider variety of variables are considered and a larger number of scenarios generated. An example can be found in some work carried out by METRO, the Municipality of Metropolitan Seattle, some 10 years ago<sup>1</sup>.

Some transport plans developed for Seattle in the 1970s used the 'blueprint' approach: a single set of assumptions about the future. Forecasts prepared on this basis were not useful because they assumed real fuel prices would increase (they declined), population and employment would continue to be concentrated in the city (they dispersed) and public transport usage would increase (it declined). To avoid a repetition of these failures, the Scenario approach was adopted. METRO began by identifying ranges for key trends: economy and trade; petroleum availability and price; public policy directions; technological innovation; demographic trends. Combinations of these variables were reduced to nine for assessment by an expert panel. Eventually, three primary scenarios were defined for use in longer-term planning, with two additional low probability scenarios for contingency planning. The five can be summarised as follows:

- prosperity continuing
- business as usual
- slow down
- regional boom
- prolonged recession.

An important aspect of the Seattle approach is that the key input variables are regularly monitored, and the agency re-evaluates the key scenarios every two to three years. The outputs are being used to prepare long-term ridership forecasts for the public transport system.

An even more systematic approach, recently used for the Channel Tunnel Rail Link and on a number of DBFO projects, is Monte Carlo Simulation (Fig 1). 'Monte Carlo sampling' is a technique using random numbers to sample from a probability distribution. The term derives from a World War 2 code name for simulation problems connected with the development of the atomic bomb. In this context it involves assigning probability distributions to all of the key variables which are driving a forecast, like:

- economic growth
- fuel prices
- demographic trends
- competition or coordination with other operators
- other aspects of transport policy.

In Monte Carlo Simulation, thousands of individual forecasts are generated, in each of which the value of one of the above variables is randomly sampled from within the probability distribution defined. Hence, a cumulative probability distribution is generated for the overall forecast (Fig 2). It is then theoretically possible to assign a probability of outcome to different levels of demand or revenue. There is clearly scope for wider application of systematic sensitivity testing of this kind.

### Example 1: The BERTS Scheme

Thailand's rapid economic growth has resulted in Greater Bangkok's population doubling in the last 30 years. The accompanying substantial increase in car ownership has led to possibly the worst traffic congestion in the world and severe pollution over large parts of the city. In addition, massive development has resulted in rapidly changing trip-making characteristics.

Some of the key features of the situation are:

- an under-developed road network with no defined hierarchy and discontinuities caused by the river and ground level railways
- severe traffic congestion which leads to long delays and highly variable travel times
- peak hour traffic spreading over other time periods
- buses and taxis severely affected by traffic congestion
- slow, overcrowded State Railways of Thailand (SRT) heavy rail system
- no metro.

The Bangkok Elevated Road and Train Scheme, described and illustrated in a previous *Arup Journal*<sup>2</sup>, is planned to be some 60km long and is composed of three separate transport modes on the same alignment:

- a dual three-lane tollway
- a mass rapid transit (heavy metro) system
- a heavy rail system (SRT).

The tollway will be a major road link, significantly affecting the ground-level road system in the corridor. The SRT services will provide a much needed suburban transit system, whilst the Community Train (CT) metro system will be designed for high volume urban flows. The size of the BERTS system and its alignment will have a major impact on existing travel patterns over most of Bangkok and it was considered essential, therefore, to develop a city-wide model for robust patronage forecasts for the scheme.

With three transport systems on the same route, the model had to be unusually complex. In addition, there are two other tollway systems in the same corridor and two other proposed transit systems that will compete for some of their length. The model had to be capable of forecasting patronage for these closely competing systems.

In addition, some 11Mm<sup>2</sup> of mixed residential, office and retail new development are part of the scheme. It was vital to represent the trips generated by these developments accurately, to reflect their impact on the demand forecasts for the scheme as a whole.

Initially, the main outputs required from the model were:

- patronage forecasts for the tollway, the SRT, and the CT systems
- traffic forecasts for local road design, with emphasis on intersections associated with the tollway ramps
- predictions of passenger movements at the SRT/CT stations for design.

Later, additional outputs were commissioned:

- revenue forecasting for the tollway and CT system
- revenue maximisation strategies.

The BERTS model<sup>3,4</sup> has the traditional four stages of trip generation, trip distribution, mode choice and assignment (Fig 4). Results were produced for two forecast years, 1998 and 2008. The model covers the Greater Bangkok area with detailed representations of all existing and proposed urban transport modes. It is one of the largest and most complex recently developed (450 zones, 2500 nodes, 8000 links).

The model is driven by socio-economic data. Bangkok has very high existing and projected growth, as illustrated by the following:

- **Population:** currently 10.4M, increasing to 13.2M by 2008
- **Employment:** currently 4.6M, increasing to 5.4M by 2008
- **GDP growth:** currently around 7.1% pa. Forecasts for 2008 employ a range of growth of 6.4% - 7.3% pa.
- **Real income growth:** representing increased spending power. This affects values of time and people's willingness to pay;
- **Vehicle ownership:** For accurate forecasting in a city like Bangkok, it is important that the vehicle availability model reflects the rapidly changing car ownership levels. Vehicle ownership relationships depend on income distribution which leads to estimates of the number of households with a car or motorcycle. The BERTS model predicts that the number of households with cars will nearly double between 1995 and 2008.

Key BERTS patronage forecasts are:

- Tollway use of 370 000 to 425 000 vehicles per day
- 1.5M - 1.9M CT passengers per day.

These forecasts are, however, derived from a series of assumptions and, while Arups chose the most likely values for the low and high growth tests, it was recognised that they were highly unlikely to be correct. The complexity of the environment and the multiplicity of variables makes it impossible to be accurate to the nearest vehicle or passenger except by luck. The key issue is to ensure that a confidence range associated with the forecasts identifies the likelihood of them being attained. This can then be used by financial institutions to inform their decisions about scheme financing. Sensitivity testing has thus been undertaken on key variables. The following examples have the most significant effects on the patronage of the BERTS system:

- fares/tolls
- competing schemes (additional infrastructure and fare/toll levels)
- population
- GDP
- value of time
- bus integration/competition
- development occupancy
- extent of corridor development.

A complex spreadsheet model was developed in Hong Kong to convert the output from the modelled AM and off-peak periods to daily totals, apply annualisation factors, and calculate total farebox revenue. The revenue forecasts were then fed into the financial analysis for the scheme as a whole, which takes into account other revenue from developments and parking, and incorporates the Build, Operating and Maintenance costs. From this, a cash flow projection was developed for the life of the scheme to assess whether the revenue stream was sufficient to cover the costs and still provide an adequate return for investors.

5. Forecast demands for BERTS; (a) tollway (bandwidth indicates scheme loading in am peak period); (b) CT system (bandwidth indicates scheme patronage in am peak period).

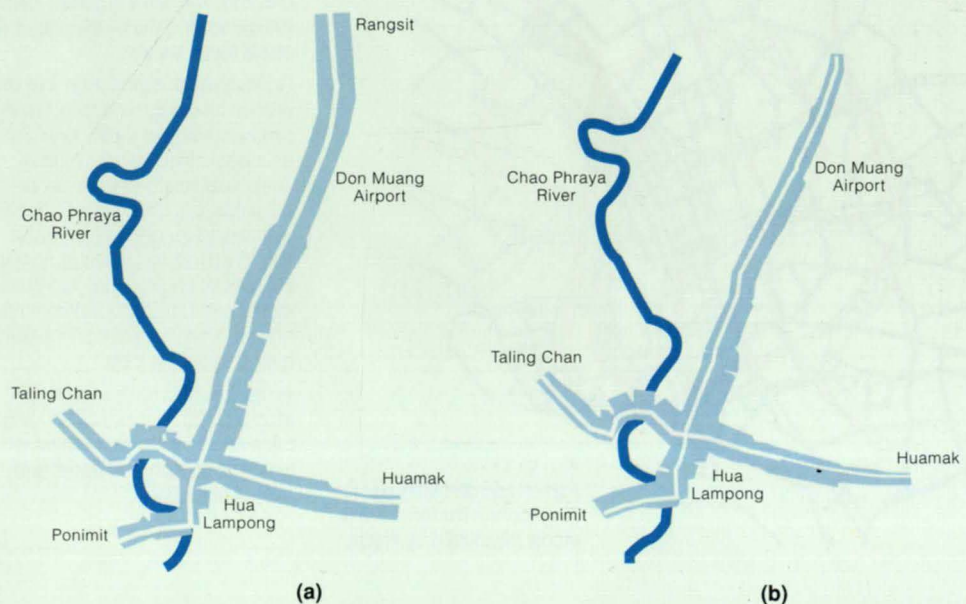

6. 'Getting the revenue in' - ticket machines at Pasir Ris terminus on the Singapore MRT network.



## Example 2: Singapore Mass Rapid Transit extensions

Arups' work in 1994/95 on the feasibility and evaluation of Singapore's North East (NE) Line and Changi International Airport extensions to the MRT (metro) system covered all aspects of forecasting travel demand, alignment studies, cost/benefit analysis, and financial appraisal.

The MRT is the backbone of Singapore's integrated public transport system. The Singapore government recognises the vital importance of an attractive network of public transport as a pre-requisite for controlling the growth of car use in one of the most buoyant economies of the Pacific Rim. Therefore, the MRT and bus networks are integrated with bus routes focused on interchange stations and comprehensive through ticketing. Public transport operators, however, are private companies, including SMRT - the metro operator. Major capital costs such as construction and rolling stock for MRT extensions are financed by public grants providing that the operation is likely to be profitable.

Arups' work involved assessing whether the NE Line, a 20km extension to the then existing 87km network, was likely to be viable; ie would revenue exceed operating cost? This required preparation of forecasts of demand by public and private transport, and projections of MRT operating costs. An integrated NE Line MRT and bus network had to be planned, which was then modelled using the forecasting model developed as part of the commission to predict patronage and revenue for the NE Line.

To assess MRT operating costs, Arups developed an operating and maintenance (O&M) cost model

using detailed inputs for staffing, maintenance costs, and energy consumption, based partly on information provided by Singapore Mass Transit Ltd. These permitted the derivation of 14 separate unit costs, developed to permit the assessment of a wide range of different operating and infrastructure options. Indirect costs (those not directly varying with MRT operation) were separately projected.

The resulting O&M cost model was applied to a wide range of possible levels of service for the NE Line, based on predictions of train run times and capacity requirements from our patronage forecasting work. The resulting annual costs were compared with corresponding revenue predictions to produce viability forecasts.

NE Line and Changi extension revenue forecasts were prepared using Arups' patronage predictions, by applying integrated fares consistent with the established network but projected to reflect likely real changes in the overall level of fares. The revenue forecasts were made using a model of the MRT fare scale represented as a function of fare against distance travelled, and applied to forecasting model outputs of boardings at each station, and passenger kilometres. The forecasting model was designed to produce these key inputs and ensure that interchange within the MRT system was represented in a way consistent with the fares system.

## Example 3: DBFO road projects in the United Kingdom

In April 1995, Arups was appointed as technical and traffic adviser to a group of international banks supporting the Connect Consortium in bidding for two of the four road schemes in Tranche 1 of the DBFO initiative: the A1(M) Alconbury to Peterborough and the A417/A419 Swindon to Gloucester schemes. Unfortunately, Connect were unsuccessful on both bids, but following on from this experience, they bid successfully for two of the concessions in Tranche 1A: the A50/A564 Stoke-Derby Link and the A30/A35 Exeter to Bere Regis schemes.

Arup Transportation's traffic advice fulfilled an audit role and covered the following main issues:

- traffic forecasting methodology and underlying assumptions
- base traffic forecasts (ie those on which the bid is based)
- downside forecasts
- sensitivity testing, including the use of risk analysis techniques
- consideration of the impact of user paid tolls
- verification of traffic measurement proposals.

The last of these is particularly crucial in a shadow tolling situation, and a thorough review of the Highways Agency (HA) requirements and the response of the bidders was undertaken. The main difficulty arose because of the conflict between using inductive loop technology to obtain accurate absolute counts and reliable classification of light vehicles (<5.2m long) and heavy vehicles (>5.2m). The advice greatly helped the banks and the bidders to understand these issues.

Considerable importance was also placed on using sensitivity testing to produce suitable traffic forecasts as an input to the financial model. There was much debate about assumptions, including the impact of induced (or generated) traffic resulting from the new roads, and the effects of projected fuel price increases. Careful judgement had to be exercised in producing suitable forecasts for the bids.

Arups advised the banks at all stages up to financial close, and have a three-year agreement to continue advising on traffic and technical matters.

## Conclusion

In this article, the intention has been to bring out the following key points:

- the growing importance of demand and revenue forecasting for transport projects worldwide
- the crucial role that demand and revenue forecasts play in scheme financing and as a starting point for design
- the complexity of the forecasting issues involved
- Arups' record in helping clients resolve commercial choices
- revenue forecasts as an essential preliminary stage in project development.

From Arups' own point of view, the close liaison achieved between Arup Transportation and other parts of the firm was essential to the success of the projects.

## References

- (1) RUTHERFORD, GS, and LATTEMAN, J. Avoiding transportation future shock. *Civil Engineering (ASCE)*, pp60-62, February 1989.
- (2) FORSTER, R and LOADER, J. International working: BERTS. *The Arup Journal*, 30(1), pp4-7, 1/1995.
- (3) EAGLESTONE, AS and SIMPSON, MJ. Multi-modal modelling for the Bangkok Elevated Road and Train System (BERTS). Citytrans Conference - Asia '95, Singapore 1995.
- (4) EAGLESTONE, AS and TEHAN, C. Multi-modal modelling in a congested city (Bangkok). Fourth European EMME/2 User Group Meeting, Brussels, May 1995.

## Credits

### Clients:

Hopewell (Thailand) Ltd

Singapore Mass Rapid Transport Corporation (Now Land Transport Authority)

### Connect

### Consultants:

Arup Transportation  
Eleanor Clark, Iain Bell, Aidan Eaglestone, Yolanda Hereadero, Ed Humphreys, Malcolm Simpson, David Thompson, John Webster in collaboration with: The BERTS team (see *The Arup Journal* 1/1995)

Arup Hong Kong  
Graham Williams, Julian Wright

### Arup Highways

Mike Carr, Bob Goldsbrough, Nigel Hailey, Colin Stewart

Ove Arup & Partners Australia  
Andrew Wisdom

Ove Arup & Partners International, Singapore  
Malcolm Fullard, Tom McCurdy

Arup Leeds  
Geoff Davidson

### Illustrations:

1, 2, 4-5: Emine Tolga

3: Simon Small

6: Ed Humphreys

7: Ove Arup & Partners

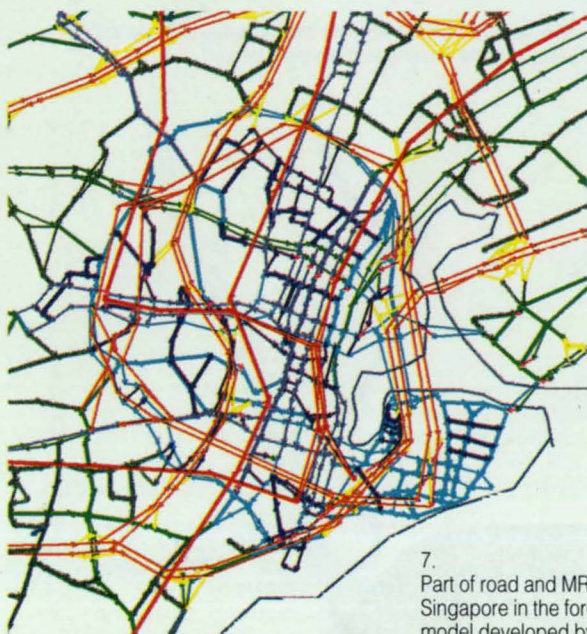

7. Part of road and MRT plot for Singapore in the forecasting model developed by Arups.

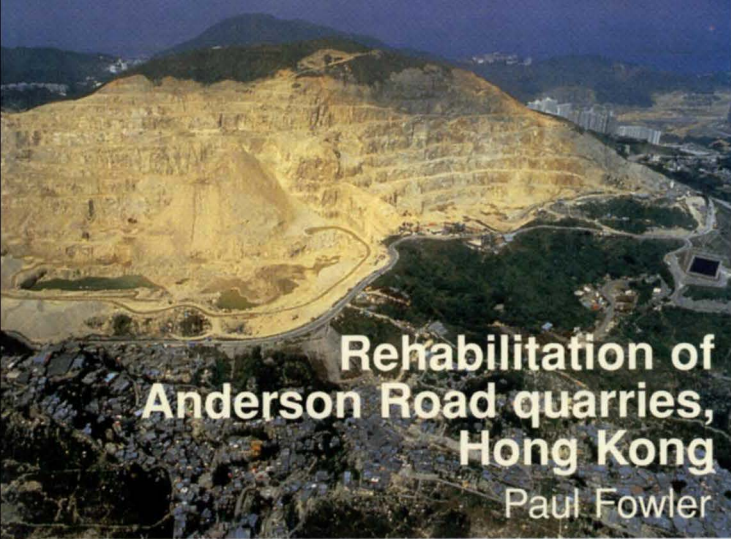

# Rehabilitation of Anderson Road quarries, Hong Kong

Paul Fowler

## Background

In the last 10 years the world's extractive industries have had to recognise growing concern over their environmental impact, as well as the need to provide for future use of sites. To rehabilitate degraded landscape has become a worldwide objective.

Quarrying in Hong Kong on the hillside above Anderson Road overlooking East Kowloon has, over the last 35 years, left steep rock faces more than 200m high and extending for 1.5km - a major landscape scar visible around Victoria Harbour, one of the most spectacular in the world. In 1989 the Metroplan Landscape Strategy for the Urban Fringe and Coastal Areas (part of a comprehensive HK government strategic plan for urban improvement) identified the hillside as degraded landscape to be restored.

Two firms work adjacent quarries at Anderson Road (ARQs) K Wah Quarry Co Ltd operate a large area near Clear Water Bay Road in the north, while Pioneer Quarries (HK) Ltd work a smaller area immediately south.

1. Existing quarries from south west.

Both operators are nearing the end of their leases and the HK Government, which owns the land, wants to ensure that any new contracts incorporate provisions to rehabilitate the quarries and surrounding areas.

In May 1991, the Planning Department and Geotechnical Control Office prepared a study brief for planning, transportation, environmental, and engineering studies of the ARQs and the surrounding areas. This was to underlay a comprehensive rehabilitation plan, implementation of which would form a part of any new quarry contracts. With government encouragement, the present quarry operators appointed a team of consultants led by Ove Arup & Partners and P&T Wallace Evans to undertake the study on a non-commitment basis.

## Study objectives

The main aim was to formulate recommendations for progressive restoration of the landscape and early handback of land to government for development through extended quarry rights. In effect, two sets of interests had to be met: those of government - on behalf of the community at large - seeking to create a landform visually acceptable and flexible in terms of future land-use development, and causing least interference to nearby communities and land uses; and those of the quarry operators whose main concern is economic viability.

## Scope of the study

- to develop a long-term, flexible, land-use concept within Metroplan's framework
- to create a visually acceptable landform
- to produce a feasible long-term road layout in and around the Study Area
- to address the effects of vehicle movements generated by rehabilitation
- to programme a phased handback of formed sites to government for development without conflict with ongoing quarry operations
- to produce a strategy for safe, economical removal and disposal of overburden
- to produce a strategy of works and remedial measures that ensure geotechnical stability of the quarry and adjoining sites, and safeguard the environment of adjoining sensitive land uses
- to phase a programme for resumption of land clearance and re-provisioning
- to produce a Landscape Masterplan in which 'core' works are progressively undertaken by the quarry operators as a means of restoration
- to define boundaries for government administration of land tenure and contractual agreements.

## The rehabilitation proposal

### Final landform

This had to be safe, stable, and visually acceptable, and in terms of excavated material meet the quarry operators' commercial and operational needs based on their current assessment of future demand for rock products - extraction of c43Mm<sup>3</sup> of usable rock over 20 years. The proposed landform, covering over 100ha (significantly larger than today), has been to create a natural-looking hillside with c45ha of platforms within a broad valley formed from the old quarry floor, separated from existing development further downhill by keeping existing topography. The ridges so formed will form a valuable barrier between the quarry operators' plant and works areas, and adjacent heavily-populated areas.

Of the 45ha of platform, 12.8ha on the periphery will be available for early handback to government (by Year 3 and Year 10).

### Recommended land use development concept

This was based on an open-space/recreation-led option, integrating both private and public housing. The scheme allowed for a total population of over 34 000 at full development - 23 000 in public and 11 000 in private housing. The public housing was in the periphery areas available for early handback. A theme park could be developed on the restored quarry floor.

### Landscape Masterplan

After assessment of the site and its visual context, several specific landscape and open space objectives were defined, relating to both the landscape restoration works and the final development and after-use of the site. The proposals were then explored and a recommended option derived through evaluation. Implementing the Landscape Masterplan will achieve the objectives by:

- restoring the degraded landscape
- maximising the site's territorial, regional and district landmark value
- maximising its recreational value
- reducing visual impact of the built development
- providing a high quality of building and landscape design
- maximising the potential for environmental improvement
- promoting private sector involvement.

The Landscape Masterplan, involving 72.4ha out of the 110ha total, is in two parts:

#### (1) Landscape strategy for restoring slopes

This phased restoration of the quarry face and other slopes over 20 years aimed to develop a landform resembling as closely as possible the adjacent natural hillsides but also acknowledging the quarrying history. The works involve full landscape restoration of the quarry face, including formation of a 'landmark' on a steep rock escarpment.

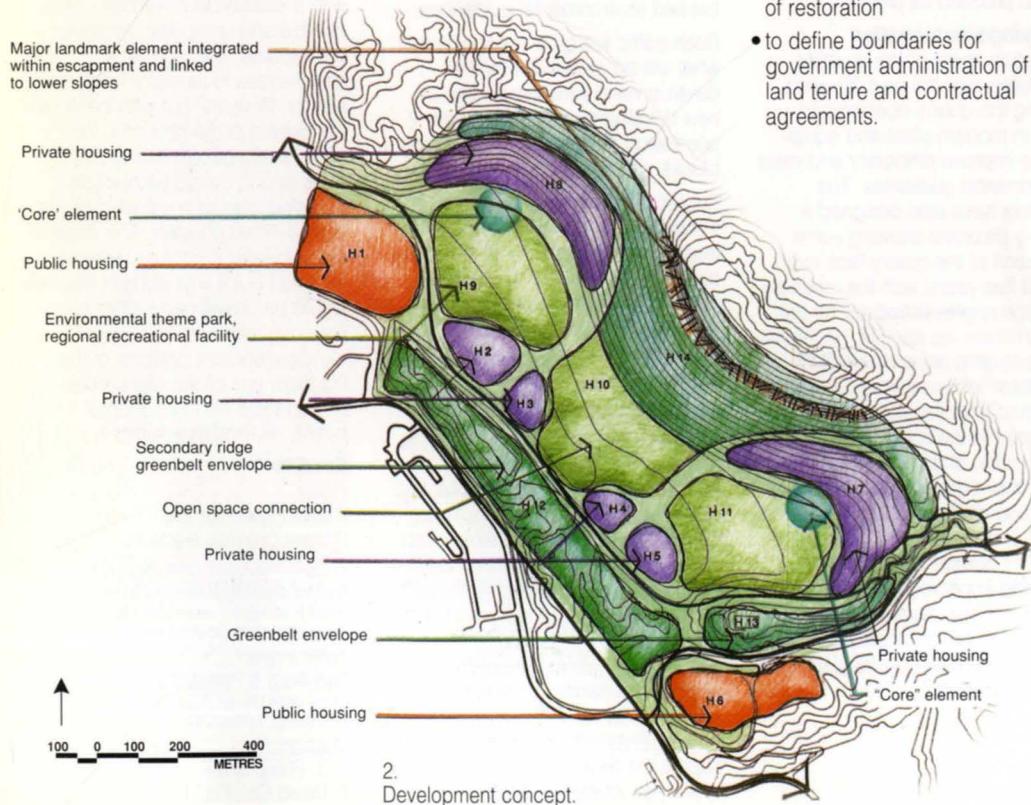



3. Proposed development looking north.

Work on the quarry face commences at the top and proceeds downslope, to rehabilitate first the most visually intrusive sections of quarry face. The planting principles were based on:

- achieving rapid establishment of vegetation
- maintaining an ecological approach to the planting
- creating natural vegetation patterns linking the ridge above the quarry with the Kowloon Hills.

A balanced plant community responsive to the environmental conditions of the ARQs area will be established, including woodland, scrubland, and grassland species. Planting trials will be needed to optimise techniques, planting media, and plant species; support facilities will include an on-site holding nursery to store the large quantities of plant material and an off-site nursery for plant propagation.

Irrigation to establish planting incorporates on-site water collection and a trickle irrigation system. Existing site overburden will be mixed with soil conditioner to produce planting media, and the restored slopes maintained for two years after handback to government.

#### (2) Landscape strategy for proposed development

The landscape and planning guidelines appreciated both the site's full potential and the fact that most development would not commence for 20 years.

Advances in construction, transport, and environmental technologies were therefore allowed for in the Masterplan. This identified an innovative and integrated development having, outside the private and public housing, an environmental theme park with a wide range of recreational and commercial elements, incorporating wind and solar power generation. The actual recreational development to be pursued will be determined closer to the date the site becomes available.

### Programme

The proposal has been to complete rehabilitation by Year 20 with development as envisaged and full occupation by Year 23, but to implement the scheme, two key items had to be addressed:

#### (1) Site clearance

The rehabilitation contract cannot commence over its full area until all land is free of encumbrances and in government control. All squatter villages surrounding the quarry had been cleared under an ongoing government programme but industrial settlements on short-term tenancy and licence, and over 30 graves, remained. These have now gone. Two years were needed to complete clearance procedures. Anderson Road - within the rehabilitation boundary - also had to be closed under the Road Works Use and Compensation Ordinance. However, some small areas of private land are still held under an agricultural lease, and resumption of these has been delayed.

#### (2) Modification of statutory plans to allow quarrying/site formation

The area to be rehabilitated is partly in the New Territories and partly in Kowloon, Anderson Road forming the administrative boundary. No statutory plan covers the existing quarry sites; outside them the land is mostly zoned green belt with a small area zoned for public housing, and other areas for government use. Under current statutory planning controls, quarrying is not permitted here. To resolve these problems, a new OZP covering the proposed rehabilitation site, with the area zoned OU (quarrying and mining), was prepared to accommodate the rehabilitation proposals. This is called the Kwun Tong North OZP. As land becomes available during and after rehabilitation, more re-zoning may be needed to allow development to proceed as planned.

#### Quarrying/site formation

Production levels at the quarries will double over the next 20 years, allowing the quarry operators to invest in modern plant and equipment to improve efficiency and meet environmental guidelines. The operators have also designed a phasing proposal showing some restoration of the quarry face over the first five years; with the relatively low slope angles proposed for the final landform, no specific geotechnical problems were anticipated. Over 8Mm<sup>3</sup> of overburden will be generated from the site - the majority excavated in the first 10 years. Identification of a suitable receiving site for this material has been a key issue, and another the environmental impact of quarrying. But with the industry's current technology, and using improved operational procedures, nuisance and negative impacts can be minimised so that acceptable environmental standards can be achieved.

### Assessment of traffic, environmental, and infrastructure impacts

The rehabilitation scheme and the development concept were tested against traffic, environmental and infrastructure considerations to confirm the feasibility for the rehabilitation scheme, to form a basis for contract negotiations for the rehabilitation contract, and to identify a realistic programme of implementation.

#### Traffic impact assessment

This indicated that several regional road links and junctions near the rehabilitated quarry site would become critical with or without the proposed development. The impact from the quarry and the proposed development was minimal.

#### Environmental impact

Key environmental issues associated with the rehabilitation of the ARQs included air quality, noise, water quality, liquid and solid wastes, blasting and visual impacts.

#### (1) During rehabilitation

Proposed mitigation measures, such as dust suppression, screening of noise sources, good monitoring, and audit of the works, could reduce environmental impacts to acceptable levels. However, during quarrying and site formation works there may be some short-term deterioration of the environment.

#### (2) From the proposed development

The impact of a population intake of 34 000 people is most significant in terms of liquid waste. The assessment showed that it could probably be accommodated although some local pipework upgrading may be needed. The impact of solid waste generation was not significant.

The proposed developments in early handback areas are close to main roads, and therefore subject to noise impacts from through traffic that exceed environmental guidelines.

Such traffic will grow irrespective of what will be generated by the development; sensitive design of new development platforms with orientation and set back of housing blocks would help reduce impacts.

Subject to the impacts imposed by through traffic, the EIA concluded that rehabilitation of the ARQs area by quarrying and site formation could be achieved within environmental guidelines and that the developments proposed for 34 000 population were feasible.

#### Infrastructure Impact

Rehabilitating such a large area of degraded landscape requires considerable engineering input, into considering infrastructure like new sewerage, stormwater drains, water supply, and utilities. It was concluded that local upgrading of downstream stormwater drainage and sewerage systems would probably be required, although this would be confirmed when the capacity of the systems was established. Most significantly, a new reservoir would be needed to supply the development, planning of which has already begun.

### Conclusion

This study formulated recommendations for progressive restoration of the landscape and the handback of land to government for development through extended quarrying rights at no direct cost to government. A safe, stable and visually acceptable landform would be created, giving maximum land use flexibility with the least interference to nearby communities and land uses. The proposals and recommendations made were considered realistic and the rehabilitation feasible.

A Planning Context Report was issued in 1991, followed by a Development Concepts Report in which development options were generated. Subsequently the scheme was developed further and five working papers issued during 1992 covering environmental impact, development traffic, quarry traffic, land issues, and landscape restoration. There were also extensive consultations with government committees, and presentations to local public bodies. The final report was issued in March 1993. Its conclusions were endorsed and the follow-actions recommended were implemented. The outline zoning plan was gazetted in 1993 and negotiations started immediately for the privately owned land. These became protracted; one landowner objected to being 'resumed' and took the government to court, arguing that the project was in effect a 'long-term quarry operation' rather than a site formation project to create land to be developed for the 'benefit of the public', a 20-year project being too long to justify a public benefit. He lost the legal battle after a long court-case, appealed and again lost before appealing to the Privy Council in London. The land owner withdrew his appeal in autumn 1996.

Meanwhile, government proceeded with a scaled-down version of the rehabilitation proposal, avoiding private land. This contract commences in January 1997, to last for 15 years, but with the recent withdrawal of the objection the original rehabilitation proposal is expected to be resurrected and included later as a variation to the scaled-down contract. The original development proposals were well received but it was agreed that they would be developed further nearer the completion date. However, the development platform at the southern end of the site proceeded on schedule with formation of the site by the HK Housing Authority.

### Credits

*Client:*  
K Wah Quarry Co Ltd  
Pioneer Quarries (HK) Ltd  
*Project manager and consultant for quarry development planning and land formation, engineering design, infrastructure assessment and traffic impact:*  
Ove Arup & Partners Eddie Chan, Albert Chee, John Davies, Paul Fowler, Thomas Kwok, Bird Wong, Terence Yip, Damon Yuen  
*Illustrations:*  
1, 3: Phillip Shaw  
2: David Chu/Paul Fowler



# San Miguel Breweries in China and Hong Kong

## Introduction

Mike Dunk

The San Miguel Corporation is one of the largest public companies in the Philippines. Founded in 1890, it generates around 4% of GNP and 7% of tax revenues for the Philippines Government through business activities including beverages, food products, agribusiness, and packaging - all market leaders in domestic markets. It has overseas operations throughout East Asia, and plans to become one of the world's top 12 brewers in the next decade. China represents a significant part of their geographic development strategy. Arups, meanwhile, has a long and successful association with the brewing industry, with clients including Guinness in Ireland, UK and West Africa; Carlsberg in the UK and Hong Kong; and Nigerian Breweries (Heineken and Star).



2. Baoding Brewery bottling hall.

1. Location map.



### Background to the China brewery

San Miguel and BADA Baoding Brewery formed a joint venture early in 1994, following an introduction by Canadian process engineers First Key, who also advised them that redundant plant from the Carlsberg Tetley Brewery in Romford, Essex, would be suitable for relocation in Northern China.

The San Miguel BADA Brewery is 2-3 hours' drive southwest of Beijing in Baoding City, a garrison town of around 2M population, with a ready local market for beer and extra labour resources. Few site managers can mobilise at a moment's notice a special site cleaning gang of 300 cadets from the People's Liberation Army in uniform, complete with shovels, rakes, and other implements of destruction!

At an early stage San Miguel set the target for first brew at 31 March 1996, allowing 21 months for transfer of the Romford Brewery and design, construction, installation, and commissioning of the new brewery. This date was achieved through remarkable efforts by a multinational project team against all the odds of inclement weather (-15°C to +40°C) and cultural challenges. Due to limitations in local utilities supplies, the new brewery is self-contained in a greenfield site. Following a feasibility study by Arups, steam and electricity are generated in an energy centre (EC) to supply the brewery and other potential industrial users, including a maltings.

### Background to the Hong Kong Brewery

San Miguel have been brewing beer in Hong Kong since 1946. With Carlsberg they face competition from over 80 brands of imported beer, but maintain leadership in the market. The taproom in the original brewery at Sham Tseng had one of Hong Kong's finest views, overlooking the new Tsing Ma suspension bridge linking Hong Kong and Lantau islands on the route to Chek Lap Kok airport.

This development potential was realised early in 1994 when the site was auctioned for a sum equal to the cost of two new breweries, with enough left over to pay a special dividend to shareholders. It had to be vacated by 6 September 1996, leaving 24 months to design, construct, install, and commission a new brewery, plus any time left over to remove valuable brewing process plant from Sham Tseng to re-use in China.

With cash in hand San Miguel decided to develop a fully automated, state-of-the-art brewery with all new plant and equipment on a 4ha site at Yuen Long Industrial Estate in the New Territories. Arups was appointed as project manager, lead consultant, and construction manager in July 1994, partly for its previous brewery experience and particularly for its understanding of local government approval. It was soon realised that the approvals process was the project's critical path and would seriously constrain timing of site activities - in particular requiring building construction and process plant installation to overlap in all areas.

Over 100 separate certificates of various kinds were obtained for and by San Miguel to allow them to continue operating a brewery and provide employment and revenue in Hong Kong. This bureaucratic challenge was met, and the new brewery started up, ahead of the original programme and with time for plant to be removed from the old brewery in accordance with Arups' decommissioning plan. The site was handed over a month early and a significant bonus paid by the new owner to San Miguel.

### Comparisons and contrasts

The following article describes the breweries and the services provided by Arups and other key players, showing how two breweries for the same client can provide completely different challenges for two Arup project teams in Hong Kong, ably supported from London, Manila and Nottingham. Cheers!

Brewery data	Baoding	Hong Kong
Location	Baoding City, Hebei Province, China	Yuen Long, New Territories
Site area	33ha	4ha.
Production capacity		
Stage 1	2Mhl pa.	1Mhl pa.
Ultimate	6Mhl pa	1.5Mhl pa
Total project value	US\$125M	US\$150M
Programme		
Arup start date	July 1994	July 1994
First brew	31 March 1996	25 April 1996
Production start-up	30 June 1996	26 July 1996

Arup services	Baoding	Hong Kong
Project management	√ (PMS support to client team)	√
Construction management	X	√
Design co-ordination	√	√
Architecture (subcontracted to APS)	√	√
Engineering		
Civil & structural	√	√
Building services	√	√
Utilities	√	X
Studies		
Decommissioning existing brewery	Decommissioning existing brewery	Decommissioning existing brewery
CHP - Energy Centre	CHP - Energy Centre	Energy management
Maltings utilities study	Maltings utilities study	Water management
Brewery expansion study	Brewery expansion study	Malt silos (steel v concrete)

# San Miguel BADA Brewery, Baoding

Iain Evans Tim Suen

## The development

San Miguel's joint venture partner BADA has many interests, and major influence, in Baoding City. Apart from an existing brewery and other ventures, BADA are also construction contractors, and own a local design institute. This unique combination of client, contractor, and sub-consultant provided some interesting working relationships for San Miguel and for Arups and helped make the fast-track programme achievable. Unlike the Hong Kong Brewery, San Miguel decided to retain project management in-house, although Arups provided UK and Chinese project management staff to support their project director. As overall design co-ordinators, as well as designers of civil and building works and some of the utilities and process piped services, Arups held regular meetings with the process engineers First Key in Canada, involving also San Miguel's brewing engineers and subconsultant architects APS. Joint visits were made to the Romford Brewery during decommissioning to obtain data on the process and utilities plant to be transported to Baoding.

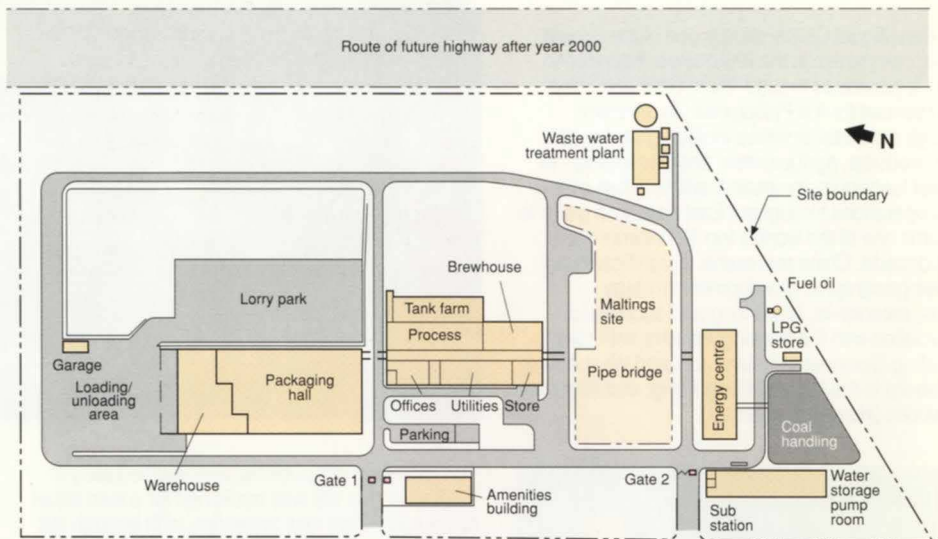

3. Layout of Baoding Brewery.

## Decommissioning Romford Brewery

Richard Henderson  
Gareth Young

Early in 1994, the Canadian brewing engineers First Key introduced San Miguel to BADA and advised the new joint venture of the suitability of redundant process plant and equipment at the former Carlsberg-Tetley Brewery in Romford for relocation to Baoding. With Arups in Hong Kong appointed as design co-ordinators for the new brewery, the Industrial Projects Group in London was well placed to advise San Miguel on the removal and refurbishment of utilities plant and on phased demolition of the Romford buildings and structures to facilitate removal.

Arups' appraisal of the existing utilities plant at Romford focused on the chiller equipment, most of it not suitable for re-use, and the compressed air plant, which was suitable. The five Broomwade reciprocating compressors were completely refurbished by a specialist contractor and rebuilt with new bearings, piston rings, and valves, and mounted on purpose-built frames with new drive motors and a new control system, incorporating a unique low energy control module.

Following demolition, removal and refurbishment, the Romford process and utilities plant went via Tilbury and Felixstowe to the port of Tianjin in China. A single convoy of nearly 100 vehicles, 5km long, conveyed all the plant from Tianjin to Baoding via a suburb of Beijing, arriving in December 1995 after a five day journey to much jubilation by the project team and the local population.

## General planning

The whole brewery forms a long, low, blue ensemble intended to blend with the predominantly flat landscape and the sky, its main buildings flanking a central elevated pipebridge carrying services between the packaging building, process building, and the Energy Centre (EC).

For drainage, the wastewater treatment building is at the lowest point, by the River Hou. Ash handling, and coal, oil, and LPG storage, are to the south, using a secondary entrance for separate delivery purposes. This 'service end' is as far as possible from the process and packaging buildings. The area between the EC and process building is being developed by BADA, in a separate joint venture, for a maltings which will obtain utilities from the brewery on a commercial basis. The east part of the site is mainly intended for future expansion to accommodate the ultimate 6Mhl pa capacity.

## Buildings

With a large site area, intended to expand to six times the size of the Hong Kong Brewery, all the packaging facilities, bottling, canning, and keging could be located at ground floor level in one large 195m x 78m building. This divides into two main compartments, for packaging and for storage, separated by a fire wall. The process building comprises two blocks, one for process plant and one for offices and utilities, each 150 x 24m and separated by the pipebridge. Ancillary facilities include the amenities building, the water and wastewater treatment plants, guardhouses and substations. The Energy Centre (EC) is described on the facing page.

## The site

The 33ha site is west of Baoding, outside the city flood protection barrier, and slopes less than 1m north-west to south-east, bounded to the south by the river. Below the topsoil, alluvial sand and clay alternate to 1000m depth, the layers also including loess silt, checked to be non-collapsible under earthquake intensity 7. The ground does not freeze in winter below 600mm. Groundwater level is over 20m below the surface and sinking, due to widespread extraction for seasonal irrigation and general usage.

After pump tests from boreholes, five 130m deep wells at 120m spacing along the western boundary were sunk to supply water for all brewery needs. The upper 45m of each is lined to allow extraction to continue by local farmers from their shallow wells. Following analysis of flooding records and discussions with the local Hydraulics Institute, it was decided to raise the site level some 2m using 300 000m<sup>3</sup> of imported fill, laid and compacted to give a suitable base for heavily loaded ground-bearing slabs in the process and packaging buildings. This also allowed a simple and cost-effective surface water gravity drainage system in open trapezoidal channels to be designed.

Subsoil conditions allowed simple spread footings for most buildings and structures with a cellular raft foundation under the fermentation tanks. Preloading was used on the cellular raft area with a 5m surcharge of topsoil for three months.

## Structures and cladding

As in Hong Kong, reinforced concrete - usually clad in the ubiquitous local ceramic tiles - is China's standard form of construction. Structural steelwork is not widely used and all except small sections are fabricated as plate girders. Here, however, the process and packaging structural systems were generally steel portal frames on reinforced concrete stub columns. Except for structural steel pipebridges, all other buildings and structures are reinforced concrete including the 60m high chimney. Imported colour-coated profiled metal cladding is used throughout the industrial buildings, although a local version has been used on the EC.



4. Construction progress, looking south at April 1996, showing the Energy Centre.

# Baoding Energy Centre

Trevor Hodgson Paul Misson

The initial utilities scheme for Baoding Brewery was based on coal and oil-fired boilers to generate steam for process needs, plus electrical power from the local grid. Very early discussions with the Power Supply Authority (PSA) in Baoding showed that the approval process for supply of power to the new facility would be quite lengthy. It would also require a sizable connection fee to assist in completion of some planned improvements to supply in the area. Arups suggested co-generation on the site, and the idea was well received. While the main design of the brewery continued, a detailed feasibility study into co-generation was completed; it showed clearly that co-generation was economically very attractive but that very significant project-specific factors would have to be addressed.

## Project constraints

Oil is expensive in Northern China. Gas is not available, but coal is plentiful and very cheap and so was chosen as the fuel for the boilers. The brewery was to be built to a very tight programme, which effectively ruled out international suppliers. Initial enquiries to local equipment suppliers demonstrated that they were very competitive on price and would promise short deliveries.

The relative cost of the locally supplied equipment was such that a very conservative view on availability could be taken without compromising the financial viability of the initial phase of the project. With the planned expansion of capacity of the brewery, and the addition of other users in the form of separate businesses

coming to the planned Industrial Park, it would be possible to reduce the degree of standby capacity as operational confidence increased. It was decided to have a duty/standby arrangement on the steam turbines initially, and to provide two duty and one standby boiler to allow for the significant maintenance on PRC plant.

Working closely with San Miguel's joint venture partner, a boiler company from Jiangxi Province was identified. They are a medium-sized boilermaker who specialise in the 35 tonne/hour boilers which are a Chinese standard size and suited the project requirements well. Through their parent company, the Jianglian Group, they were prepared to take turnkey responsibility for the supply of all equipment including sub-contracting the supply of 2 x 6.8MW turbo alternators to the Nanjing Turbine Company.

To meet the time frame, very few changes to standard Chinese practice could be introduced. The buildings would be of reinforced concrete design as would the coal conveyor structures. One significant change, however, which Arups could not resist was in the orientation of the turbines, which by making alternator to alternator reduced the size of the 'standard' turbine hall. By careful planning, the combined plot plan was reduced by some 30%, compared with standard PRC design. In June 1995 the final decision to go ahead was given by the San Miguel BADA Brewery team, and the contracts were put in place, giving just 12 months to achieve completion of the newly-titled 'Energy Centre'.

## Project specifics

In view of the likely levels of simultaneous electrical and thermal power demand, a brewery is a very suitable site for co-generation: typically there is a steady base load for power demanded

by refrigeration chillers. In this case, of the estimated 6.8MW of available power, these consume 2.0MW. Other steady loads are maintained by utility plant at 1.5MW. The remaining demand is highly variable being dependent on largely unquantifiable operational activities. Steam loads are even more variable, though for major processes such as brewing and packaging the pattern of use can be determined.

With a constant base electrical load for the chillers and batch brewing activities, it is essential to maintain reliable electrical power. A steam accumulator is included in the design to provide an independent source of steam dedicated to process use, whatever the turbine requirements. The accumulator is sized to provide an instant supply of steam for approximately 15 minutes. This is sufficient time for the less responsive chain gate, stoker-fired boilers to increase their output to meet variable process demands.

The basic system parameters are:

- Provide process steam at 8.5 bar gauge and 5°C superheat at the building limit.
- Peak process steam load for Phase 1 anticipated to be 45 tonnes/hour. Rapid changes in process steam load anticipated, as items of brewing equipment demand (or cease to demand) steam almost instantaneously. Variations could be up to  $\pm 7T/hr$ , lasting for 30 minutes.
- Provide electrical power at 10kV and 50Hz at the HV switchboard.
- Peak process power demand for Phase 1 anticipated to be 5.5.MWe. Rapid changes in electrical load and power factor anticipated, as large motors start or stop. Variations could be up to  $\pm 1MWe$ , lasting for 30 minutes.

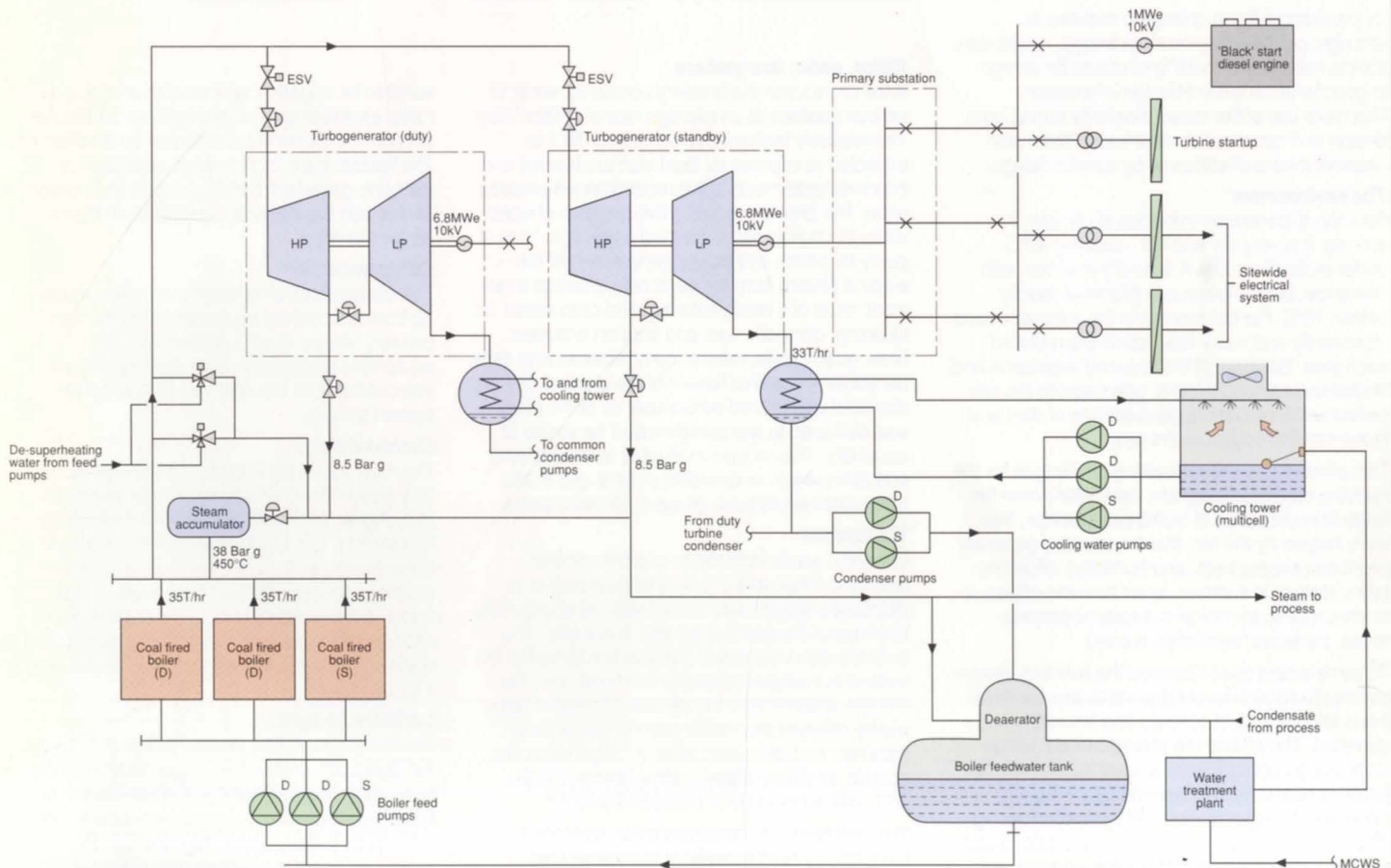

5. Baoding Energy Centre.



6. Offices in northwest corner of process building.

▼ Text continued from page 18

### Engineering services

The success of the engineering services work for the project was a result of close collaboration between Arups' Hong Kong engineers of all disciplines, with specialised input from colleagues in London's Industrial Projects Group (IPG). Arups was not only responsible for the overall co-ordination of all design activities on the site, but also had full design responsibility for the packaging hall Services, brewery utilities, and building services.

#### Let's get connected

As overall co-ordinators Arups designed and implemented the distribution routing around the site and along the central pipebridges. To progress the early design, they adopted a system using Points of Connection (POCs), identified in every area for each utility and service under Arups' design responsibility. Allowances were also made for process lines which the process engineers and research indicated may be necessary.

By providing fully co-ordinated sections at strategic points along the main bridge, Arups were able to release the building structure for design in good time, on limited design information. Maximum use of the space, flexibility during both design and construction, and future expansion capability were all achieved by careful design.

#### The environment

Baoding experiences extremes of climate. In summer it is very dry and hot, reaching 40°C under a cloudless sky. It is as dry in winter, with little snow, but temperatures plummet rapidly below -15°C. For two months in the summer it rains incessantly and many fatal floods are reported each year. Because of the reduced vegetation and limited natural wind breaks, gales across the site collect and distribute huge quantities of dust and loose matter throughout the year.

This presented some interesting challenges for the building services designers, particularly over the large occupied area of buildings. In winter, they were helped by the fact that the brewery generally produces excess heat (and humidity), offsetting fabric losses. In summer, apart from the offices, it is uneconomic to cool all but special process areas, so natural ventilation is used.

To some extent this influenced the building design, utilising fixed high level ridge vents and low level inlets fitted with dust screens and shut-off dampers. The offices are served by heat pump units using cooling towers in summer and waste process heat in winter. General space heating is not normally required, but frost protection during shut-downs is very important. The decision to use electric heaters may at first appear unusual, with large quantities of cheap steam available, but on-site generated electricity is very cheap and a significant load on the EC increases stability during shut-downs when most of the process plant is not operating.



7. Turbine assembly on site in the Energy Centre.

8. Control Centre.

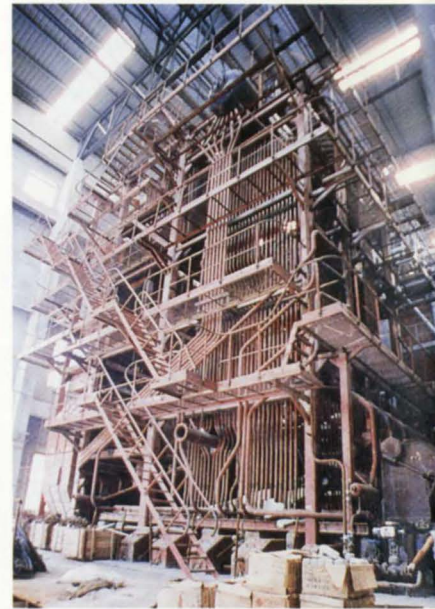

9. Boiler under construction in the Energy Centre.

#### Water, water, everywhere...

In full production the brewery consumes water of various qualities at an average rate of 5500m<sup>3</sup>/day. The relatively high water/beer ratio of 10:1 is expected to improve as local staff are trained and improvements made to the reconditioned process plant. The brewery requires two qualities of water whilst the boilers require a third, very high, level of purity for steam and power generation. All the water is filtered from the wells before further treatment, most of it being softened and chlorinated for cleaning, domestic use, and support activities. Brew quality water retains many minerals and salts beneficial to the final flavour of the product, but is sterilised and filtered before use. All of the plant was delivered to site prefabricated for speed of assembly. This proved invaluable as the building and tanks were not available on time and in situ fabrication would have delayed commissioning.

#### Wastewater

Domestic waste from toilets and the canteen passes to local septic tanks and soakaways; a distributed system was not considered appropriate because of the scale of the site. In contrast, the considerable volumes of process waste had to be treated in a single location to minimise cost. The effluent streams from the various processes have widely different properties placing demands on materials and designers alike. A single drain may contain, at different times, effluent from 1°C to 90°C with a pH value of between 2 and 12.

The treatment plant selected takes advantage of the relatively high quantity of biological waste washed from the brewing processes.

Waste beer and slurry makes good feed stock for an anaerobic decomposition process, so after an aerobic conditioning stage the effluent is digested to produce harmless and quite nutritious water

suitable for irrigation, and solid byproducts which make excellent agricultural fertiliser. As the site is surrounded by farmland, this was an ideal solution. The lightest byproduct is large quantities of methane gas which can be used to fire the boilers or maintain the digester's temperature during the winter months.

#### Compressed air

The compressed air system was mainly made up from refurbished equipment from the Romford brewery. Arups' design utilised as much equipment as possible, but made significant improvements in the controls, air quality, and system stability.

#### Carbon dioxide

The most useful byproduct of a brewery is CO<sub>2</sub> gas, which is liberated in large quantities (1300kg/hr) during fermentation of the malt sugars into alcohol. It is used in counter-pressuring the brew vessels as they are emptied, and finally in each individual packaged beer product. Coming from the fermenters the CO<sub>2</sub> is wet and rather strong smelling, and the processing plant collects, washes, dries and filters the gas before liquefying it for storage.

#### Let there be light...

Because there is little reliable power in this area, the decision to install on-site generation was taken soon after the project started. When the brewery is fully operational the main source of power will be the 6.8MW turbo-generators in the EC. Standby power, sufficient to maintain only essential plant, is provided by three 1.2MVA diesel generators. Finally, for expediency a 1.0MW grid supply was provided which will be used to operate some of the auxiliary plant in the EC when grid power is available.

# San Miguel Brewery, Hong Kong

Alice Chow Andrew Harrison Richard Marzec

## The development

San Miguel intends this brewery to be a showcase for its operations in East Asia, showing leadership in quality, innovation, and technology.

It incorporates a high degree of automation and was designed to satisfy the highest standards of energy efficiency, water management, and environmental control.

Brewers usually have strong views (though they often vary) on planning their breweries and the relationships between the various processing and packaging facilities. Conceptual planning of the small Yuen Long site had been carried out prior to Arup involvement by San Miguel and their process suppliers, together with local architects Asia Project Services (APS) who later became Arups' subconsultant. Early advice was taken also from a local geomancer, resulting in the administration building being planned to take into account views of the dragons on a nearby hill.

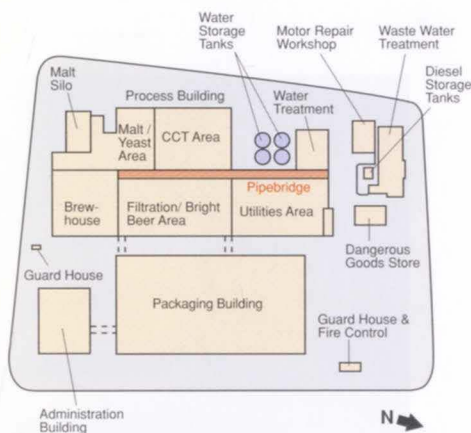

10. Layout of Hong Kong Brewery.



The brewery comprises four main areas:

### • Process building:

160m x 70m on plan with varying building heights from one to five storeys, housing all the equipment for beer production. Brewing itself embraces malt storage and processing, the main brewhouse, wort cooling, and spent grain handling. After brewing, the product passes to the fermenting and storage facilities which include the filtration, yeast propagation and beer recovery systems.

This building also houses most of the utility services systems, including steam generation, compressed air, carbon dioxide recovery, glycol cooling, ammonia refrigeration, water treatment, storage and distribution, and electrical substation/distribution.

### • Packaging building:

A two-storey (18m) structure, 108m x 40m on plan, including facilities for bottling, canning and kegging, plus palletising, washing, pasteurising, and packing equipment. Warehousing space for the finished product, a second electrical substation, and a standby diesel generator are also provided.

### • Administration building:

37m x 30m, containing offices, reception area, canteen and amenities. The large reception area with a full height (three-storey) atrium includes two old copper brewing vessels on display, recovered from the original brewery. The building also has a lower ground floor for parking.

### • Ancillary buildings:

Wastewater treatment plant, dangerous goods store, guard houses, LPG store, fuel oil storage and motor repair workshop, plus hardstandings and roadways.

## Foundations

The geology consists of superficial fill and marine deposits overlying metamorphosed sedimentary strata (siltstones, sandstones, and marble), as well as igneous rocks. Large cavities occur within the marble in some locations. Arup geotechnical engineers were familiar with the area and the ground conditions and confidently advised San Miguel that marble was unlikely to be found, even though it had been located on an adjacent site. The site investigation proved this to be correct.

Ground floor slabs in brewery buildings are subjected to uniformly distributed loads of 30-40kN/m<sup>2</sup>, plus high point loads from process plant and a need for some highly loaded plant bases to be isolated from adjacent areas. Steel H-piles driven to depths of 20-25m support all buildings and structures. Ground floor slabs are suspended between a grillage of ground beams supported on piles, whilst piled reinforced concrete rafts are provided for heavily loaded areas including tank farms.

11. Old copper brewing vessel in reception area.

## Structures and cladding

In situ reinforced concrete is by far Hong Kong's most popular form of construction and was used throughout for buildings and structures, including the malt silos and the entablature supporting CCTs over the cellars. All the process building's long span roofs are in structural steel, which is also used for pipebridges and the secondary steelwork for access to the process plant. In the packaging building a reinforced concrete beam and slab at the first floor supports steel portal frames carrying the roof. Roof and wall cladding to the process and packaging buildings is coated profiled metal sheeting in the San Miguel house colours.

A proprietary curtain walling system is used in the administration building with full height glazing to the entrance atrium.

## Process engineering and utilities

The brewery operation involves production of up to six brands of beer and packaging/storage of the finished products. San Miguel employed two German specialist process designers/suppliers: Huppmann Handel for the production equipment and Klockner Holstein Seitz (KHS) for packaging.

As the project developed, Arups' design scope and co-ordination role expanded as it became clear that there were in fact numerous other specialist suppliers, all direct appointments to San Miguel with minimal description of their scope and responsibilities in the associated purchase orders. The refrigeration, CO<sub>2</sub>, steam, and compressed air systems were designed by Huppmann Handel with Arups advising on local standards and regulations and assisting with government approvals. Arups was involved in these utilities packages significantly more than usual, due to the quirks of the Hong Kong approvals system and the process designers' approach. Submissions relating to dangerous goods, pressure vessels, emissions, noise, general water usage, and adoption of cooling towers were required by different government departments.

## Water supply and wastewater

Brewing requires both treated and untreated water, with a separate supply from the mains. Breweries use significant amounts of water, and Arups prepared a water management study showing that a water/beer ratio of 5:1 could be achieved through water-saving measures.

With the 5:1 ratio, 1120 - 2000m<sup>3</sup>/day of wastewater will be generated, depending on production levels. Treatment has to comply with local authority requirements and an upflow anaerobic sludge blanket treatment plant has been employed. This process has become the most popular anaerobic technology in Europe and East Asia for treating wastewater from industries like brewing, distilling, dairy, sugar processing, etc; San Miguel's is the first such plant in Hong Kong. Biogas (75% methane) is produced as a byproduct of the treatment process and is either flared off or burnt in the dual-fuel steam boilers.

12. Front elevation.



### Primary electrical distribution

Two substations serve the development - one primarily for the process building and the other for the rest of the site. The original masterplan had the process building substation significantly far from the load centres, which are mainly in the utilities area. Arups proposed an alternative with the substation above the air compressor room; this reduced both cabling/busbar and building costs.

### Building services

The challenge here was to provide systems that would support the processes in the buildings reliably, simply, and with suitable technology. The systems include mechanical ventilation, air-conditioning, fire suppression, water services, fuel oil storage and distribution, building drainage, electrical power, standby/emergency power, lighting, public address, fire detection and alarm, telecommunications, vertical transportation, security systems, earthing, and lightning protection.

### Fire safety engineering

Fire engineering is a new concept in Hong Kong, only formally recognised in 1996 by the Buildings Department. Fire engineering principles were successfully applied to avoid fire protection of roof steelwork, minimise requirements for smoke reservoirs to the packaging building, and permit compartments with volumes greater than 28 000m<sup>3</sup>.

## Arup services

The three aspects of Arups' comprehensive appointment by San Miguel were:

1. Project management
2. Design and design co-ordination
3. Construction management.

These aspects, summarised below, were approximately equal to each other in terms of resources and fee allocation.

### 1. Project management

The San Miguel Brewing Group (SMBG) in Manila retained responsibility for overall technical direction and for procuring and expediting process plant and utilities equipment, supplied mainly from Europe. SMBG deployed one of their senior managers in Hong Kong to provide a single point of contact with the Arup project team. Early activities following Arups' appointment

14. Water storage tanks.



13. Fermentation tanks.

included advice to SMBG on selecting other Hong Kong consultants, including independent cost consultants (EC Harris) and environmental consultants (ERM).

Meanwhile Arups' project manager and his support team prepared a revised master programme to reduce the overall project period from 27 to 24 months, as part of the project plan which also incorporated a detailed work breakdown structure (WBS). This identified every specific work package under general headings of Design, Procurement, Construction, or Installation for each facility, down to individual plant items where necessary. A detailed programme based on the WBS identified the critical activities and provided milestones for monitoring and reporting monthly to San Miguel. Arups' project control system (PCS) was used to register all document exchanges on the project.

Arups was responsible for managing the delivery of imported plant and equipment from the docks in Hong Kong, by canal and by road depending on the size of tanks and vessels. Due to limited site space, a separate laydown area was leased at Yuen Long and deliveries co-ordinated on a daily basis to suit construction progress and access. As a separate commission the firm carried out a study of decommissioning and removing plant from the existing brewery, and prepared an implementation plan to suit the projected completion of the new brewery (30 June 1996) and the target date for handing over the existing site to the new owners (6 September 1996).

Once design was effectively completed and construction under way on all fronts, the project management team moved onto site to manage construction and installation.

### 2. Design co-ordination

Apart from the challenge of satisfying local regulations, the most demanding task in designing a fast-track brewery is to extract design data from process engineers, ie static and dynamic load criteria plus demands for utilities. Process engineers are reluctant to provide data until plant items have been ordered, and the client prefers to place orders on a 'just in time' basis.

Arrangements were made for Arups' design team to visit the existing brewery in Hong Kong and other San Miguel breweries, both in production and under construction in the Philippines. A design



16. Bottling hall.



brief was prepared during frequent meetings with the department heads at the existing brewery and room data sheets prepared. Design review workshops were held with SMBG and the process engineers in Germany and Hong Kong. Regular meetings were held also with local government departments, particularly Building and Fire Services, and with local utilities companies.

Although most of the design was carried out in Hong Kong, the London Industrial Projects Group provided significant input, particularly liaising and co-ordinating design with the German process engineers. Other Arup offices undertook structural design - the packaging building in Nottingham and the administration building in Manila.

### 3. Construction management

Due primarily to the fast track programme and limited site area, an early decision was made to limit the number of direct works contractors on site. Although Arups was prepared to let the works into smaller packages on a facility-by-facility basis, this proved neither necessary nor advantageous. As design progressed and approvals were extracted, three principal works packages were let by competitive tender: for Piling and Substructure,

General Building, and Process Installation; together with 10 other works contracts. Arups' construction management team of approximately 12 people of different disciplines included the project manager, construction manager and planning engineer, supported by technical clerks and administrative staff. Technical co-ordination and supervision of civil and building works, M&E and utilities installations, and process installations were led by a senior engineer in each case, supported by field engineers. The resident site team included also representatives from SMBG, from the process engineers, and from the independent cost consultant.

The limited time for the main contracts meant that the process installation contractors had to share the site, accesses, and often working spaces with the general building contractor. This was planned and expected and made a condition of all contracts, but still caused great frustration to all concerned, requiring particular negotiating and counselling skills from the construction managers at regular co-ordination meetings.

Remarkably, process installation was completed in less than seven months to allow commissioning to start on programme on 28 March 1996. The contractor then provided attendance while SMBG and their process engineers and suppliers commissioned the brewing and packaging systems. Meanwhile the general building contractor finished civil and building works around them, and the facilities were all completed on schedule.



15. Administration building.



The brew: ready for the last stage... Good health!



### Credits

#### Client:

San Miguel Brewing International Ltd (SMBIL) [Baoding]  
San Miguel Brewery Hong Kong Ltd (SMBHK) [Hong Kong]

#### Technical direction:

San Miguel Brewing Group (Manila) [both]

#### Process engineers:

First Key (Canada) [Baoding]  
Huppmann Handel/KHS (Germany) [Hong Kong]

#### Design co-ordinators:

Ove Arup & Partners

#### Baoding Brewery

##### Hong Kong Core Team:

WJ Au, Clement Chan, LM Chan, Spencer Chan, YL Cheng, Eddie Choy, Brian Chu, Clement Chung, Simon Chung, Iain Evans, CY Ho, Oliver Kwong, Desmond Lau, Davis Lee, Jimmy Li, Tim Suen, HW Tam, Fiona Tsui, Wang Zhong Hua, Jeff Willis, William Wong (design co-ordination & engineering design)  
Joseph Chi, Mike Dunk, Jack Ho, Paul Misson, David Wong (project management services)  
John Chan, Danny Cornish, Nick Thompson (site liaison)  
Albert Ho, Derrick Leung, Brian Littlechild, Anatasia Tsak, Paul Yau, Terence Yip (geotechnics)  
WC Chan, Power Chan, Awena Lau, Francis Lam, Maggie Lam, David Lai, Candy Mok, TC Ngai, KL To, Sunny Yuen, (CAD/drafting)

##### UK Core Team:

Davar Abi-Zadeh, Stephen Campbell-Ferguson, Florence Coupaud, Diane Gilchrist, Richard Henderson, Trevor Hodgson, Robert Hyde, Andy Keeling, John Kellell, Marline Morrison, Chris Owen, David Pascall, Colin Pearce, John Redding, Denise Rogers, Clodagh Ryan, Adrian Salter, Peter Samain, Manan Shah, Brian Shepherd, Sasi Suresh, Gareth Young

#### Hong Kong Brewery

##### Hong Kong Core Team:

Henry Arundel, Alice Chow, Mike Dunk, Lawrance Fung, Bob Knight, Richard Marzec, Cliff Mountney, Andy Ng, Pat O'Neill, Franco Pittoni, Ken Sayer, Kevin Tang, Oz Wilde, Alan Wilson, Andrew Wolstenholme (project management & construction management)

Nilda Bernal, Ken Chow, Eric Ching, Brian Chu, Paul Dunne, Ken Fan, Suzanne Freed, Calvin Fu, Mike Harley, Andrew Harrison, Rick Higson, Simon Hocknell, Lawrence Hui, Mark Jones, K M Lam, Samson Lee, Steve Leung, John Powell, C K Tse, Matt Volgyi, Y C Wright (design)

Anson Cheung, John Davies, CS Ho, John Hodgson, Terence Yip (geotechnics)

Mario Chan, Albert Chee, Eric Cheung, Paul Ip, David Lai, Francis Lai, KC Lai, Maggie Lam, Awena Lau, Lydia Lee, Dennis Mak, Martino Mak, Candy Mok, HC Or, WS Tang, Ambrose Wong, Damon Yuen, Sunny Yuen (CAD/drafting)

##### UK Core Team:

Peter Bressington, Andy Keeling, Lindsay Murray, Peter Samain, Brian Shepherd, Richard Smith, Sasi Suresh (London)  
Steve Cliff, Mark Davidson, Paul Geeson, Duncan Overy, Roger Pickwick, John Read, Julian Thew, Chris Webb (Nottingham)

##### Manila Team:

George Acuna, Leo Aguilar, Judy Allarey, Wilhelmina Cruz, Rico Gomez, Anamarie Larin, Elenita Mijares, Peter Monkley, Eduardo Palaganas, Generoso Ponce, Freddie Silva, Chris Stowe.

#### Arup Subconsultants:

Asia Project Services (HK) Architects [both]  
BADA Design Institute (Baoding)  
BCEL Design Institute (Beijing)

#### Quantity surveyors:

E C Harris [both]  
Gleeds [Baoding]

#### Construction managers:

Gammon Management Services [Baoding]  
Ove Arup & Partners [Hong Kong]

#### Civil & building works contractors:

BADA Construction [Baoding]  
Gammon Construction Ltd [Hong Kong]

#### Process installation contractors:

Steineker + Fineasy and others [Baoding]  
Clough Bell Joint Venture+ KHS and others [Hong Kong]

#### Illustrations:

1, 3, 5, 10: Damon Yuen/Trevor Slydel  
2, 6, 8, 9: Lu Ying  
4, 7: Iain Evans  
11, 16: Damon Yuen  
12-15: Colin Wade

